

# Owner's Manual

Mercedes-Benz



# 380 SL

1984

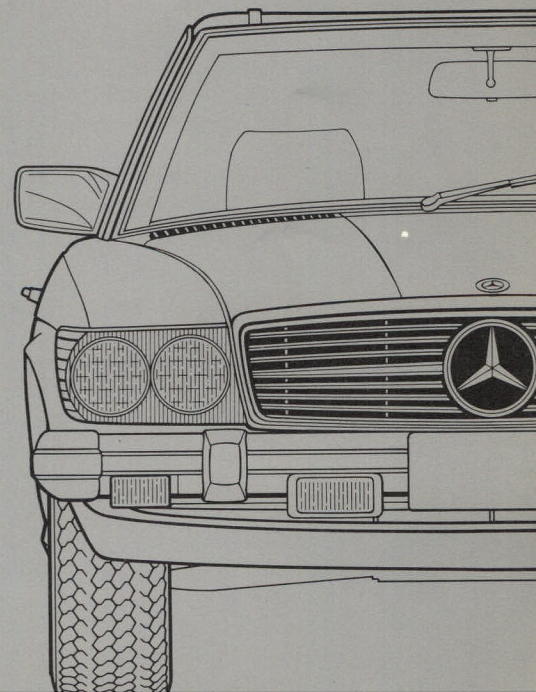

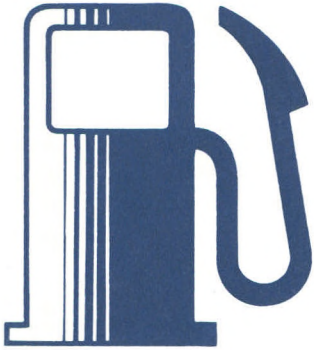

## Drive Sensibly – Save Fuel

Fuel consumption depends to a great extent on driving habits and operating conditions.

In order to save fuel you should:

- ensure that tire pressures are correct
- not carry unnecessary loads
- remove ski racks or roof-mounted luggage racks when not in use
- not warm up your engine at idle and with the vehicle at standstill
- avoid frequent acceleration and deceleration
- avoid frequent braking
- avoid unnecessarily high speeds
- have all the maintenance jobs specified by us carried out at regular intervals by a MERCEDES-BENZ service station.

Driving in low temperature weather, in stop-and-go city traffic and on short hops, and in hilly country also increases fuel consumption.

Mercedes-Benz



# Owner's Manual

---

## 380 SL

Chassis 107

1984

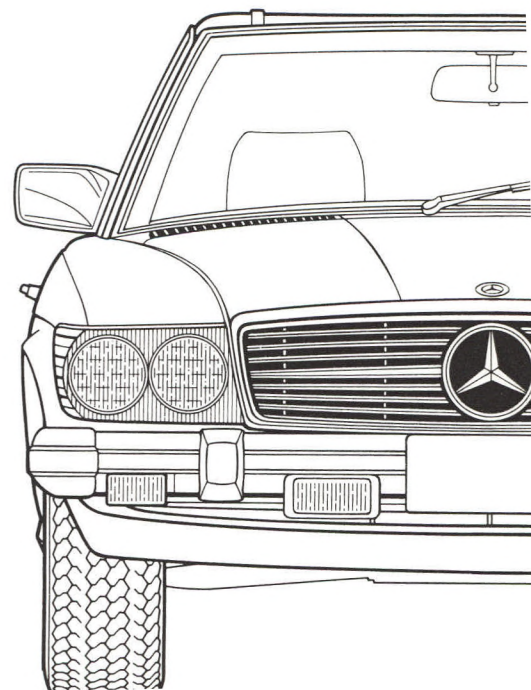



Our company and staff wish you many hours of enjoyment with your new vehicle.

You have placed a lot of trust in our company name by purchasing a MERCEDES, from which you may expect that it will give you long service, with a minimum of trouble and that it is easy to operate.

We have just one request to make, hoping that it will benefit you as well:

Please do not put this manual aside without first carefully reading it.

This manual contains many important recommendations that could help you gain better control over your MERCEDES and more pleasure while driving it.

We wish you many miles of motoring pleasure.  
Daimler-Benz Aktiengesellschaft

## Contents

---

*Special equipment is also described in this manual, including operating instructions wherever necessary. Since there are special-order items, the descriptions and illustrations herein may vary slightly from the actual equipment of your vehicle.*

*If there are any equipment details that are not shown or described in this Owner's Manual, your MERCEDES-BENZ dealer will be glad to inform you of correct care and operating procedures.*

### The last page

What you should know at the gas station

### Vehicle Operation

Instruments and Controls .....	8
Instrument Cluster .....	10
Keys, Doors .....	12
Flat Key, Master Key and Supplementary Key .....	12
Obtaining Replacement Keys .	12
Opening, Locking and Unlocking of Doors .....	12
Central Lock System .....	13

Seats .....	14
Adjustment of Driver's Seat and Front Passenger Seat ....	14
Safety Head Restraints .....	15
Seat Heater .....	15
Seat Belts .....	16
Controls .....	17
Steering Lock .....	17
Lighting Switch .....	18
Combination Switch .....	19
Cruise Control .....	20
Automatic Climate Control .....	21
Various Equipment .....	26
Exterior Mirrors .....	26
Inside Rear View Mirror .....	26
Sun Visors .....	27
Heated Rear Window .....	27
Shelf below Rear Window ....	27
Lighter .....	28
Interior Lamps .....	28
Power Windows .....	28
Soft Top .....	29
Hardtop.....	31
Radio.....	33

### Driving

Hood .....	40
Parking Brake .....	40
Regular Inspections .....	41
Catalytic Converter Cautions ...	42
Starting and Turning off the Engine .....	43
Starting and Shifting Gears ....	44
Safe Driving .....	46
Brake Pad Wear Indicator Lamp .....	47
Brake Fluid .....	47
Charge Indicator Lamp .....	47
Fuel Reserve Warning Lamp ..	47
Oil Pressure Gauge .....	48
Coolant Temperature Gauge ..	48
Emission Control .....	48
Engine Oil Consumption .....	48
The First 1500 km/1000 Miles ..	49
Driving Economically .....	49
Gauge for Economical Driving (ECONOMY) .....	49
Special Operating Conditions ...	49
Winter Driving .....	49
Hints for Driving .....	50
Tire Chains .....	50
Traveling Abroad .....	50

**Vehicle Care**

MERCEDES-BENZ Maintenance System ..... 52  
 Spare Parts Service ..... 53  
 Cleaning and Care of the Vehicle ..... 53  
     Jobs related to Care..... 54

**Practical Hints**

Ash tray ..... 58  
 Luggage or Ski Racks ..... 58  
 Spare Wheel, Jack, Vehicle Tool Kit ..... 58  
 Wheels, Tires, Changing Wheels ..... 59  
     Wheels, Tires ..... 59  
     Changing Wheels ..... 60  
     Tire Inflation Pressure ..... 61  
 Checking Fuels, Coolants, Lubricants, etc. .... 61  
     Engine Oil Level Check ..... 61  
     Checking Coolant Level ..... 62  
     Automatic Transmission Fluid Level ..... 63

Electrical System ..... 64  
     Headlamp Adjustment ..... 64  
     Replacing Bulbs ..... 64  
     Fuses ..... 68  
     Battery ..... 68  
     Spark Plugs ..... 68  
 Tow-starting and Towing the Vehicle ..... 69  
 Jump Starting..... 70  
 Unlocking of the Filler Flap..... 70

**Technical Data – Fuels, Coolants, Lubricants, etc.**

Identification Plates ..... 72  
 Vehicle Data Cards ..... 73  
 Warranty Coverage ..... 73  
 Technical Data ..... 74  
 Fuels, Coolants, Lubricants, etc. 76  
     Capacities ..... 76  
     Engine Oils ..... 78  
     Brake Fluid ..... 78  
     Coolants ..... 79  
 Service Literature ..... 80  
 Consumer Information ..... 81

**Vehicle Operation** ▶

**Driving** ▶

**Vehicle Care** ▶

**Practical Hints** ▶

**Technical Data – Fuels, Coolants, Lubricants, etc.** ▶





# Vehicle Operation



## Instruments and Controls

---

*For more detailed descriptions see quoted pages.*

- 1** Swivelling side ventilation outlets (page 21)
- 2** Control lever for side ventilation (page 21)
- 3** Parking brake release button (page 40)
- 4** Hood release lever (page 40)
- 5** Parking brake pedal (page 40)
- 6** Combination switch (page 19)
- 7** Lighting switch (page 18)
- 8** Instruction tag (except tourist vehicle).  
Use only unleaded gasoline
- 9** Cruise control (page 20)
- 10** Instrument cluster (page 10)
- 11** Horn control
- 12** Steering lock with ignition/starter  
switch (page 17)
- 13** Swivelling outlets for nonheated fresh air (page 21)
- 14** Outside temperature gauge
- 15** Switch for front dome lamps (page 28)
- 16** Switch for automatic antenna (page 38)
- 17** Switch for heated rear window (page 27)
- 18** Radio (page 33)
- 19** Automatic climate control (page 21)
- 20** Ash tray with lighter (page 28, 58)
- 21** Switch for left power window (page 28)
- 22** Switch for left seat heater (page 15)
- 23** Switch for hazard warning flasher system
- 24** Switch for right seat heater (page 15)
- 25** Switch for right power window (page 28)
- 26** Adjusting lever for exterior mirror on front  
passenger side (page 26)
- 27** Glove compartment (to open, shift handle  
sideways). Only illuminated if steering lock is in  
position "1" or "2".
- 28** Loudspeaker cover, right and left

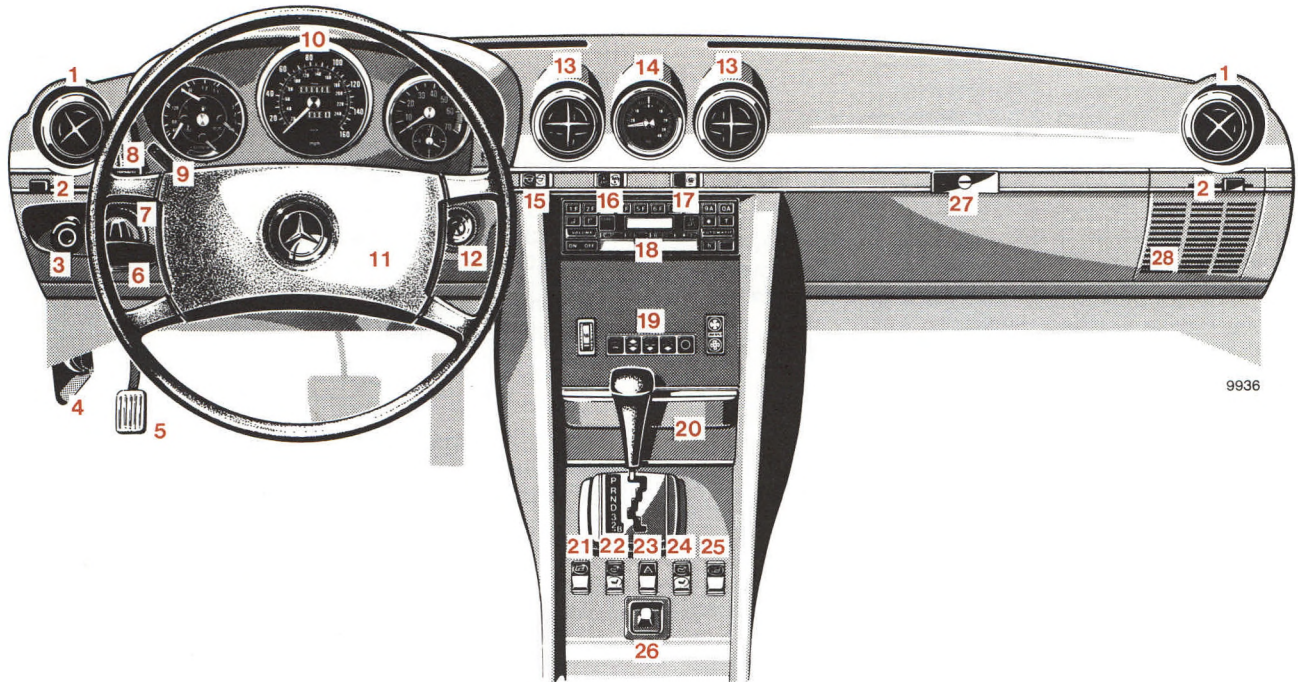

## Instrument Cluster

---

- 1 Gauge for economical driving (ECONOMY).  
See page 49
- 2 Coolant temperature gauge (° C)  
Up to red marking: Maximum permissible temperature for an anti-corrosion/antifreeze-blended fill protecting down to  $-30^{\circ}\text{C}/-22^{\circ}\text{F}$ .  
See page 48
- 3 Fuel gauge with reserve warning lamp (yellow)  
Comes on when the steering lock key is moved to driving position “2” and must go out when the engine is idling. See page 47  
Fuel reserve and capacity, refer to page 77 and last page
- 4 Oil pressure gauge (bar). See page 48
- 5 Main odometer
- 6 Trip odometer
- 7 Knob for clock adjustment  
(press in for adjustments)
- 8 Electric clock
- 9 Tachometer
- 10 Red marking on tachometer:  
Excessive engine revolutions
- 11 Turn signal indicator lamp, right (green)
- 12 O<sub>2</sub>-Sensor replacement indicator lamp (red):  
When the indicator lamp comes on, the O<sub>2</sub>-Sensor must be replaced
- 13 Seat belt warning lamp (red)
- 14 Brake pad wear indicator lamp (yellow):  
Lights up during braking if the front wheel brake pads are worn down. See page 47
- 15 Dimmer knob for instrument lamps,  
continuous adjustment
- 16 Resetting knob for trip odometer  
(push button)
- 17 Brake warning lamp (red) comes on if
  - the parking brake is engaged
  - too little brake fluid is in the reservoir
- 18 High beam indicator lamp (blue)
- 19 Charge indicator lamp (red):  
Comes on when the steering lock key is moved to driving position “2” and must go out when the engine is idling. See page 47
- 20 Turn signal indicator lamp, left (green)

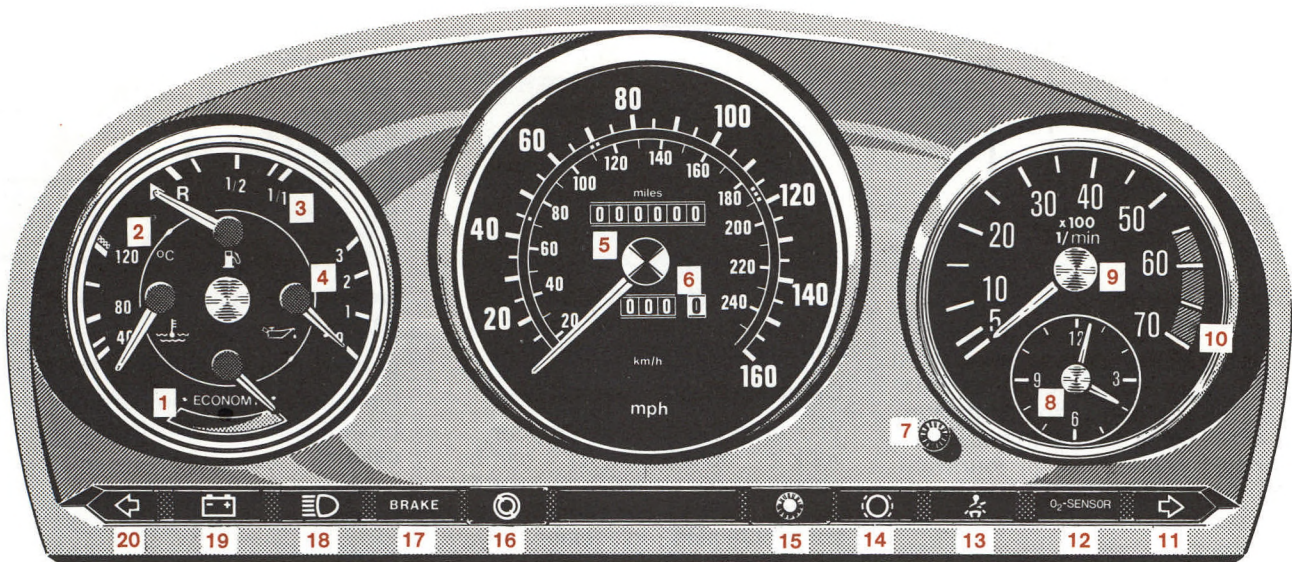

9732

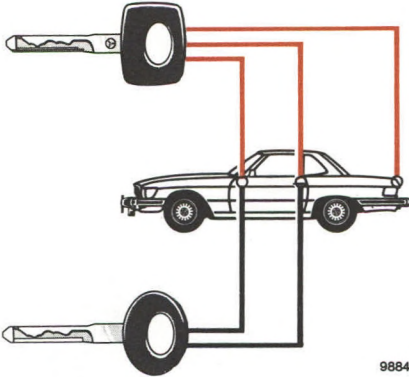

### Flat Key

The flat key fits all vehicle locks. We recommend that you carry the flat key with you and keep it in a safe place so that it is always handy, if needed (e.g. in your wallet). Never leave the flat key in the vehicle.

**Master Key** – square headed – fits all locks on the car.

**Supplementary Key** – rounded head – fits only the door locks and the steering lock. This key is intended to be used whenever the car is

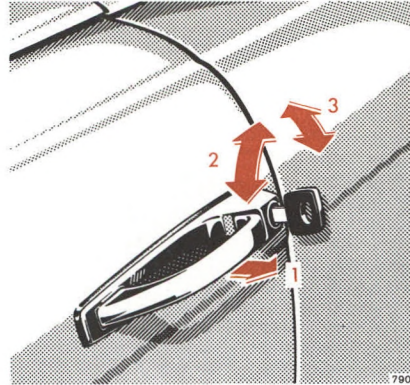

left with an attendant. Be sure to lock glove compartment and trunk with the master key.

### Obtaining Replacement Keys

You are given 4 keys with your vehicle. Replacement keys can be obtained only via MERCEDES-BENZ service stations. For security reasons, obtaining replacement keys requires considerable time.

### Opening the Doors

From outside: pull handle outwards (1).

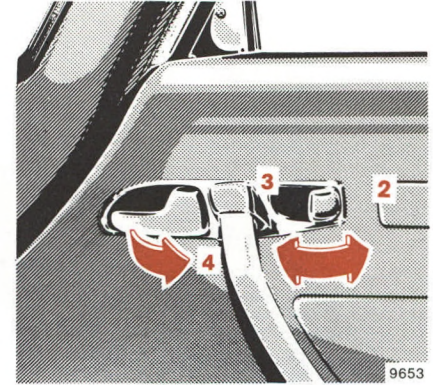

From inside: pull handle in door panel (4).

### Locking and Unlocking of Doors

From the outside: turn key.  
From the inside: actuate safety catch.

- 2 Unlocking
- 3 Locking

The driver's door can be locked only if it is closed and the door latch has properly engaged.

### Central Lock System

The central lock system enables the front passenger door, the fuel tank filler flap and the trunk lid to be locked or unlocked together with the driver's door. When locking or unlocking, the locking levers on both doors must move simultaneously. If one locking lever fails to do so, the lock of that particular door is not properly engaged. The door must then be opened and closed correctly.

With the central lock system in the locked position, the front passenger door can be locked and unlocked either with the locking lever or with the key.

Actuation of the locking lever on the front passenger door, however, is not possible when the central lock system is in the unlocked position.

The trunk lid can also be unlocked separately by turning the master key counterclockwise to the stop. Push

the trunk lock button in with it and lift the lid. Return the key to its initial position and withdraw it. To lock the lid, close it firmly. It will then be locked again by the central lock system.

A provision has been made to facilitate permanent locking of the trunk lid for positive prevention of access to trunk by unauthorized persons.

Before leaving vehicle with an attendant, lock trunk with master key (square head) by turning key clockwise to stop (tumbler slot vertical), then provide attendant with round-headed supplementary key. Thus, the trunk lock has been excluded from the operation of the central lock system and cannot be opened except with the square-headed master key, that you keep in your possession.

To reverse this, turn trunk lock counterclockwise back to horizontal position of the tumbler slot with master key. Lock will then be reengaged in central lock system; that is, it will automatically be locked or unlocked depending on whether the driver's door is locked or unlocked.

The central lock system operates on vacuum generated by the engine. A reservoir allows the central lock system to be actuated about five times after the engine is turned off. If the system can then no longer be engaged, idle engine for a short period.

If no vacuum is available, doors and trunk have to be locked individually with the key. The fuel tank filler flap, however, remains unlocked.

Note:

If the filler flap cannot be opened when the central lock system is unlocked, refer to "Unlocking of the Filler Flap" (page 70).

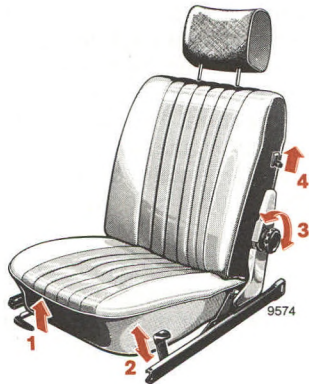

### Adjustment of Driver's Seat and Front Passenger's Seat

Fore/aft adjustment: lift handle (1), push seat backward or forward and allow handle to reengage.

Seat elevation (6 positions): Each time handle (2) is pulled up, the seat is raised by one notch. If the handle is pushed down completely, the seat will return to its lowest position. Afterwards, handle can be pulled up to engage the seat in its first position to avoid clicking noise.

Back rest tilt: turn handwheel (3).

For full reclining of backrest, seat should be moved to one of the forwardmost positions and headrest removed. For driving, return backrest to upright position, push seat back, and replace headrest.

After disengaging the stop by lifting knob (4), the back rest can be folded forwards.

### Note:

Prior to operating the vehicle, the driver should adjust the seat height for proper vision as well as fore/aft placement and seat back angle to insure adequate control, reach, operation, and comfort. Be certain seat is "locked in" by sliding front/rear until full engagement is assured. The head restraint should also be adjusted for proper height so that when the cushion is tipped completely forward, it should form a cradle behind the seat occupant's head (see page 15).

Both the inside and outside rear view mirrors should then be adjusted for adequate rearward vision. Fasten seat belts.

All seat, head restraint, and rear view mirror adjustments as well as fastening of seat belts should be accomplished before the vehicle is put into motion.



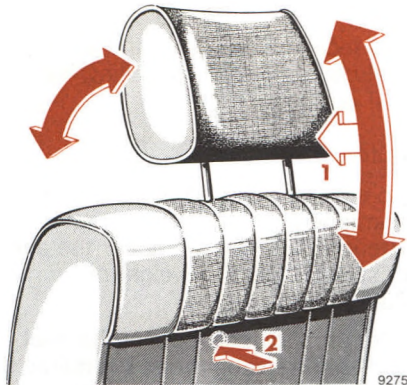

**Safety Head Restraints**

Adjust head restraint to support the back of the head approximately at ear level.

Height adjustment:

Pull head restraint slightly forward (1) and slide up or down.

Removing head restraints:

Pull head restraint up to the stop. Depress release button (2) to be felt under the covering material in

rear of back rest and pull up head restraint quickly, holding it by the LH head restraint post (viewed in driving direction). Finally pull out head restraint completely with both hands.

**Seat Heater**

The seat heater can be switched on when the steering lock is in position "1" or "2".

Heater operation:

Push in upper switch portion; position 1 = normal heater operation, one indicator lamp lights up.

Push in lower switch portion; position 2 = rapid heating, both indicator lamps light up.

After approximately 5 minutes in the rapid heating mode, the heater automatically switches to normal operation and only one control lamp will stay on.

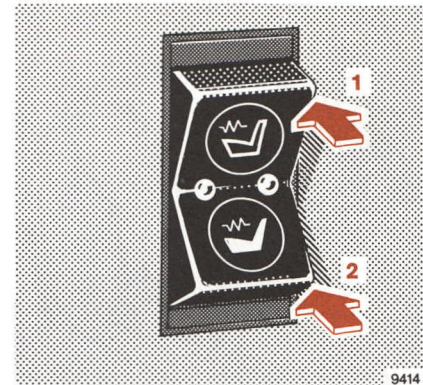

Turning off heater:

If one control lamp is on, press in upper part of switch, position 1.

If both control lamps are on, press in lower part of switch, position 2.

The heater automatically turns off after approximately 30 minutes of operation.

Note:

When in operation, the seat heater consumes a large amount of electrical energy. It is advisable not to use the seat heater longer than necessary.

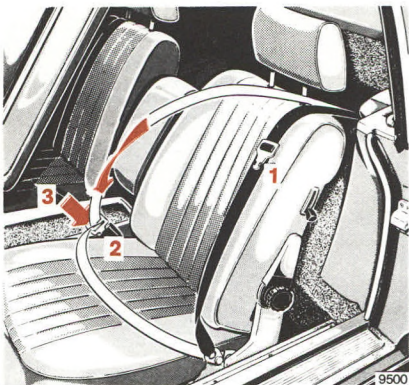

### Seat Belts

#### Warning System:

The indicator is illuminated for 4–8 seconds after turning the steering lock key to position “2”. If the seat belt of the driver’s seat is not fastened a warning buzzer sounds simultaneously.

#### Fastening:

- Pull belt with latch plate (1) over shoulder and lap. The belt must not be twisted.
- Press latch plate (1) into buckle (2) and allow to engage audibly.
- The belt must be tight and must be checked for tightness immediately after fastening and regularly during the trip. If required, tighten lap belt by pulling up on the upper belt section.

#### Unfastening:

- Depress red button (3) in buckle.
- Return latch plate (1) to initial position.

#### Operation:

The seat belt inertia reel stops the belt from unwinding further in case of vehicle deceleration or if the belt is pulled out quickly.

#### Functional test:

The locking function of the inertia reel can be tested by pulling the belt out quickly.

#### Note:

No seat belt can be used for more than one person. Belts are not intended for children under the age of six or under the weight of 23 kg/50 lb.

After an accident, inspect the seat belts and replace them, if required. The belt anchors in the vehicle should also be checked.

Replace damaged belts immediately.

Belts must not be routed via sharp edges.

No modifications which may affect the efficiency of the belts must be made.

For cleaning and care of belt webbing, refer to page 54.

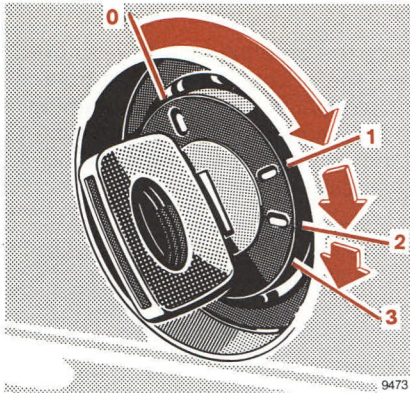

### Steering Lock

- 0 Steering is locked when the key is withdrawn and the steering lock is engaged. The key can be withdrawn only in zero position.

#### Note:

Do not remove key from steering lock while the vehicle is in motion as this will cause the engagement of the steering lock thus rendering the vehicle inoperable.

- 1 Steering is unlocked. (If necessary, move steering wheel slightly to turn the key clockwise to position "1".)
- 2 Driving position.
- 3 Starting position.

For starting and turning off the engine, refer to page 43.

#### Notes:

The following items can be operated with the key in steering lock position "1".

Wiper, windshield washer, headlamp flasher, lighter, glove compartment lamp, radio, seat heater, electrically adjustable exterior mirror.

A warning buzzer sounds when the key has been left in steering lock positions "1" or "0" and the driver's door is opened.

With the engine at idle speed, the charging rate of the alternator (output) is limited.

It is therefore recommended to turn off unnecessary electrical consumers while driving in stop and go traffic. This precaution helps to avoid draining of the battery.

An effective measure to preserve battery power is to turn off the following consumers:

Seat heater, heated rear window.

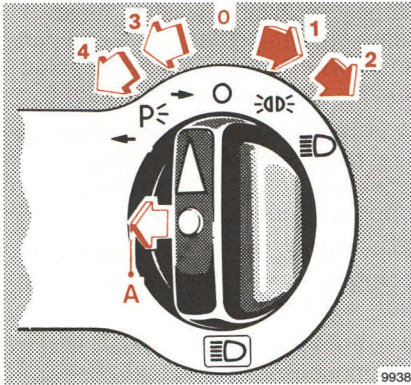

### Lighting Switch

- 0 Off-position
- 1 Parking lamps (includes side marker lamps, tail lamps, license plate lamps, instrument panel lamps)
- 2 Same as pos. 1 plus headlamps
- 3 Standing lamps, right
- 4 Standing lamps, left
- A Fog lamps (turn to position 2 and pull out to first detent = same as position 2 plus fog lamps)

### Note:

With the steering lock key removed and the driver's door or the front passenger's door open, a warning buzzer sounds if the vehicle's exterior lamps are not switched off (standing lamps excepted).

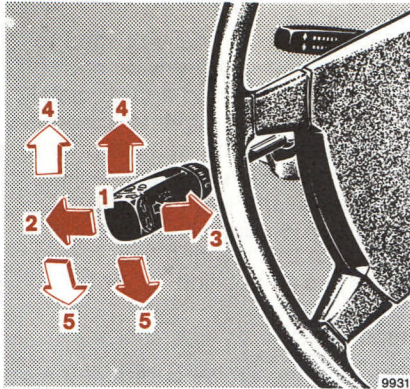

**Combination Switch**

- 1 Low beam (lighting switch turned clockwise to 2nd notch)
- 2 High beam (lighting switch turned clockwise to 2nd notch)
- 3 High beam flasher (high beam available independent of lighting switch position)
- 4 Turn signals, right
- 5 Turn signals, left

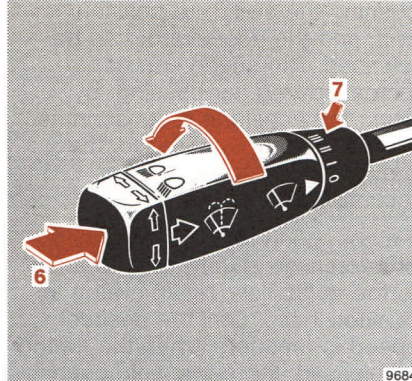

To operate the turn signals, move the combination switch past the point of resistance (up or down). The switch is automatically cancelled when the steering wheel is turned by a large enough angle.

To signal minor directional changes of the vehicle, such as changing lanes on a highway, move combination switch to the point of resistance only and hold it there.

- 6 Control for windshield washer system  
When the washer system is switched on, the wipers also operate.

- 7 Windshield wiper control
  - 0 Windshield wiper switched off
  - I Intermittent wiping
  - II Normal wiper speed
  - III High wiper speed

**Note:**

If one of the turn signals fails, the turn signal indicator system flashes and sounds at a faster sequence than under normal operating conditions.

Fog lamps will only operate together with low beam headlamps. Fog lamps are turned off automatically when lighting switch is returned to off-position.

## Controls

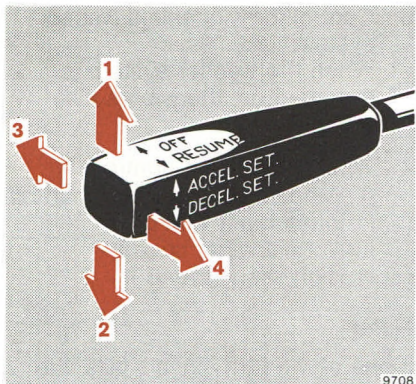

### Cruise Control

Any given speed above approximately 40 km/h/25 mph can be maintained with the cruise control by operating the switch.

- 1 Setting (touch switch)  
Accelerating (hold switch)
- 2 Setting (touch switch)  
Decelerating (hold switch)

Normally the vehicle is accelerated to the desired speed with the accelerator. Speed is set by briefly

pushing the switch to position 1 or 2, and the accelerator can be released. The speed can be increased (e.g. for passing) by using the accelerator. As soon as the accelerator is released, the previously set speed will be resumed automatically.

If a set speed is to be increased or decreased slightly, e.g. to adapt to the traffic flow, retain switch in position 1 or 2 until the desired speed is reached. When the switch is released, the newly set speed remains.

- 3 Cancelling  
To cancel the cruise control, briefly push lever to position 3.  
The cruise control will also be cancelled if the brake pedal is actuated or if the vehicle speed drops below approximately 40 km/h/25 mph.

- 4 Resume  
If the lever is briefly pushed to position 4 when driving at a speed exceeding approximately 40 km/h/25 mph, that speed is resumed which was set prior to the cancellation of the cruise control. The last memorized speed is cancelled when the key in the steering lock is turned to position "1" or "0".

### Important:

Only use the cruise control if the traffic conditions make it advisable to travel at a steady speed.

Position „Resume“ should be engaged only if the driver is fully aware of the previously set speed and wishes to resume this particular preset speed.

When driving with the cruise control, the selector lever must not be shifted to position "N" as otherwise the engine will overrev.

## Automatic Climate Control

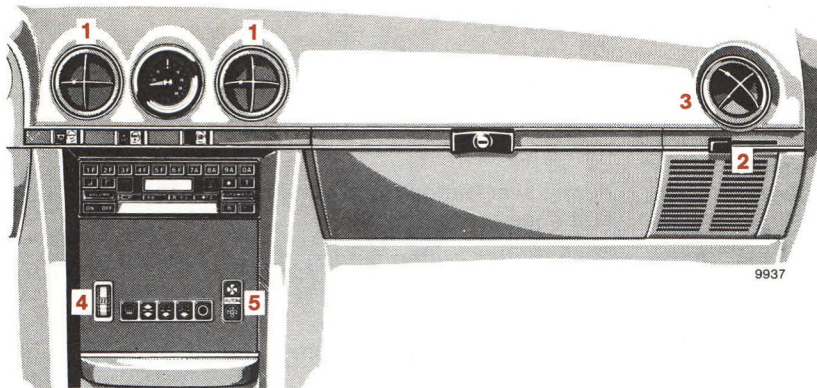

For proper operation of the automatic climate control system, keep the windows closed, the soft top up and the hardtop in place.



The engine must be running for the ACC unit to work.

Heating, cooling and air distribution within the vehicle's interior is automatically controlled.

Furthermore, settings are available for extreme weather conditions, enabling the defogging of the windshield or air ventilation to top and bottom. This is accomplished with the temperature selector (4), the push buttons, and the fan switch (5).

The air volume of movable nozzles (3) can be adjusted with levers (2). Levers (2) to center of car = open

All push buttons and fan control buttons should be operated individually. The indicator lamps in the individual buttons light up when pressed with the lighting switch in position 1 or 2.

We recommend settings  and  only, in connection with the desired fan setting. The following instructions explain the remaining settings.

## Automatic Climate Control

### Temperature Selection (° C)



The interior temperature can be adjusted by turning the temperature selector wheel. The selected temperature is reached as quickly as possible and maintained. A basic setting of 22° C/72° F is recommended. In order to avoid undesirable temperature fluctuations, a set temperature should be readjusted in small increments.

To override the automatic climate control, turn the temperature selector wheel to either extreme end position “MAX” or “MIN”.

“MIN” = Peak cooling performance, the system operates mostly with recirculated air and a small amount of fresh air is added. If the fan control is set to “AUTOM”, it will run continuously in speed No. 5.

“MAX” = Maximum heating performance. If the fan control is set to “AUTOM”, it will run continuously in speed No. 5.

### Fan Setting

 Selection for fan settings can be made as follows:

Push upper button for maximum fan speed (6th speed).

Push lower button for minimum fan speed (1st speed).

Push middle button (spring loaded) for automatic control of air supply within 2nd through 5th fan speed range.

Setting  = Always maximum fan speed.

### Functions



 Off

In this setting, the air fresh supply to the interior of the car is shut off, (to prevent entrance of odors, i.e. while driving through tunnels, etc. or to prevent the entrance of water from automatic car wash). Use this setting only temporarily while driving.

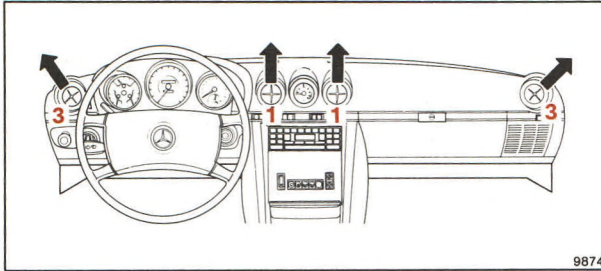



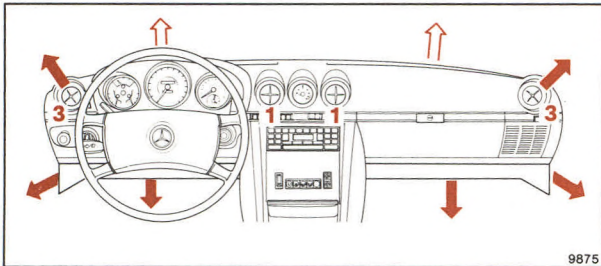

9874

-  Economy setting – Ventilation
-  Normal setting – Cooling



9875

-  Economy setting – Heating
-  Normal setting – Heating

 **EC (ECONOMY)** = Economical setting; the air conditioning compressor stays off.

In any other settings, the air conditioning compressor comes on with ambient temperatures above  $+2^{\circ}\text{C}$  /  $+36^{\circ}\text{F}$ .

We recommend this setting to be used with cool outside temperatures so that the air conditioning compressor stays off in order to save fuel.



In the ventilation mode, air is emitted from inserts (1) and (3).

In the heating mode, warm air is primarily supplied to the foot area. In addition, air will be channeled to the nozzles (3) and the doors. Only an amount of air sufficient to prevent fog build-up under normal climatic conditions will be channeled to the windshield. In the heating mode, air will occasionally be channeled to the nozzles (1).

With cold outside temperatures, the fresh air supply and the fan remain turned off until the engine coolant has warmed up slightly.

 **Normal Setting**

We recommend this setting with humid and warm outside temperatures.

The setting  corresponds with setting  but, in addition, the air can be cooled as necessary.

## Automatic Climate Control

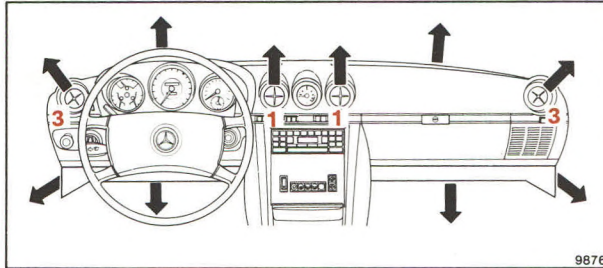

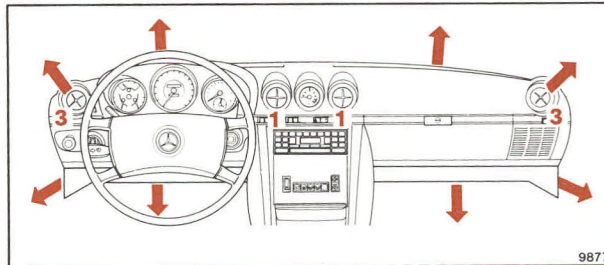

 Multi-Level ventilation – Cooling



 Multi-Level ventilation – Heating

### Multi-Level

This setting is necessary for clearing a fogged windshield. As soon as possible, reset to  or .

In the heating mode, air will be channeled to the windshield, the foot area, the nozzles (3) and to the doors; in the cooling mode, additionally to the nozzles (1). In the heating mode, warm air will be emitted periodically from the nozzles (1).

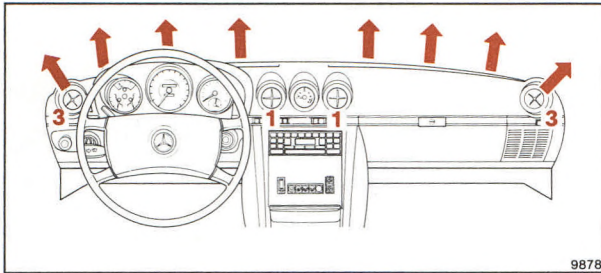

### Defrosting

### Defrosting

Independent of the position of the temperature selector wheel and the fan speed setting, maximum heated air will be channeled to the windshield and nozzles (3), for side window defrosting.

#### Note:

The air conditioner removes considerable moisture from the air during operation. It is normal if water drips on the ground through openings in the car floor.

## Various Equipment

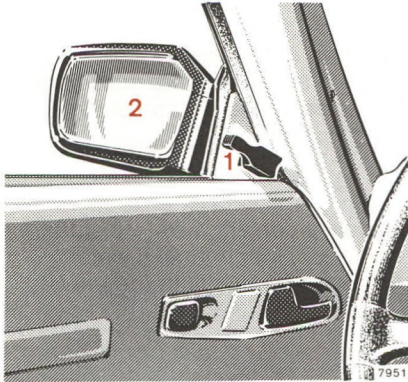

### Exterior Mirrors

Driver's side:

The exterior mirror (2) can be adjusted from inside the vehicle by moving adjusting lever (1) in the desired direction.

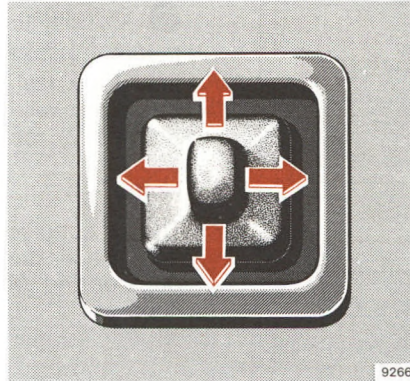

Passenger side:

Turn key in steering lock to position "1" or "2". The exterior mirror can be adjusted by means of the switch.

Note:

If the mirror housing has been forcibly moved from its normal position, it must be repositioned by applying firm pressure.

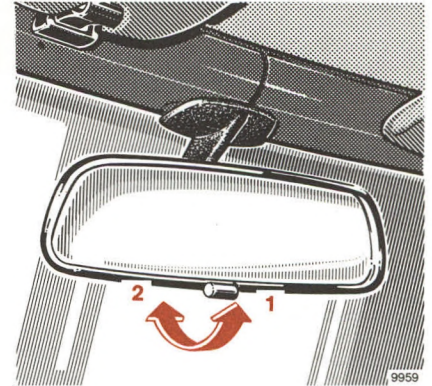

### Inside Rear View Mirror

The mirror can be tilted to the anti-glare night position by means of the lever at its lower edge.

1 = Normal position  
2 = Anti-glare night position

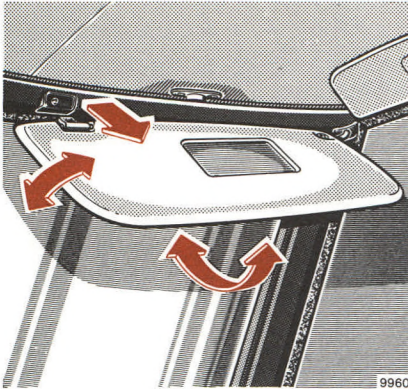

### Sun Visors

Swing sun visors down to protect against sun glare.

If sunlight enters through the side window, disengage visor from inner mounting and swing to the side.

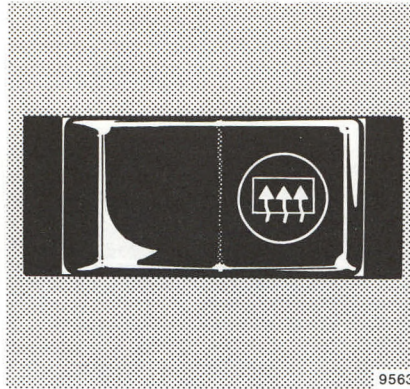

### Heated Rear Window

With engine running, press rocker switch to right to turn on, to left to turn off.

When the rear window heater is turned on, the indicator lamp in the switch comes on.

A heavy load is imposed on the battery due to the high power requirement. For this reason, switch off the heated rear window as soon as it is demisted or defrosted. It is shut off automatically after a maximum of 20 minutes. Remove snow or ice from window before starting to drive.

### Shelf below Rear Window

The shelf below the rear window should not be used to carry objects. This will prevent such objects from being thrown about and injuring vehicle occupants during an accident or sudden maneuver.

## Various Equipment

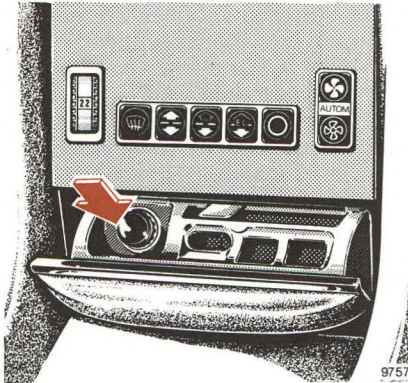

### Lighter

Turn key in steering lock to position "1" or "2".

Press in lighter; it will pop out automatically when hot.

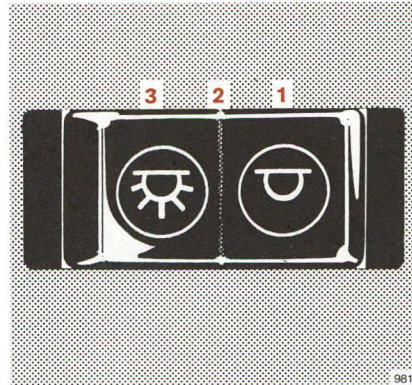

### Interior Lamps

The switch for the front dome lamps has 3 positions.

Position 1: the lamps are switched on and off (delayed) by the door contact switches.

Position 2: lamps are switched off permanently.

Position 3: lamps are switched on permanently.

### Power Windows

The power windows can only be operated with the steering lock in position "2".

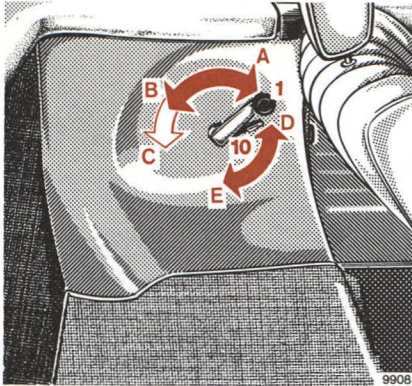

If possible, park vehicle in the shade as continuous exposure to sun rays can prematurely deteriorate.

To lower or raise the soft top or to remove or attach the hardtop, find two locking handles in a bag stowed in the glove compartment. They are used to engage or disengage locks (4). Put locking handles back into the glove compartment after use.

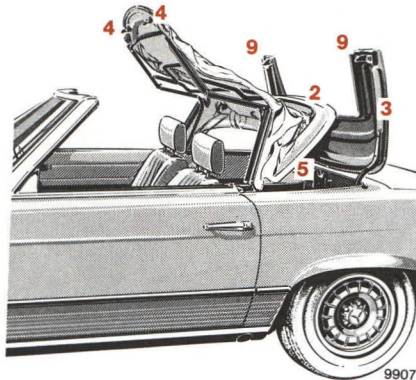

#### Lowering the soft top:

A wet or frozen top must not be folded, until thawed and dry.

Open side windows or doors before raising or lowering the soft top.

1. Unlock rear bow (2) and compartment cover (3) by rotating lever (1) to position C. Lever will automatically return to position B. If the rear bow cannot be raised in this position, move lever (10) to position E.
2. Lift up rear bow as high as it will go. In doing this, be sure the rear window is folded inward free of kinks.
3. Open top storage compartment cover (3).
4. Disengage top framework at front by turning locks (4) inwards. Remove handle after turning lock.

## Soft Top

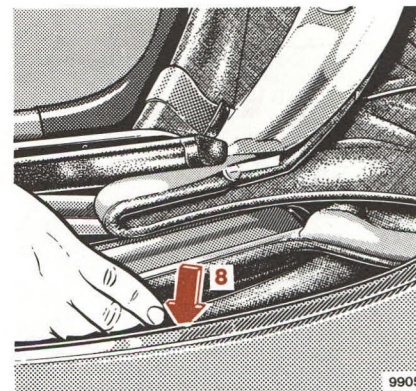
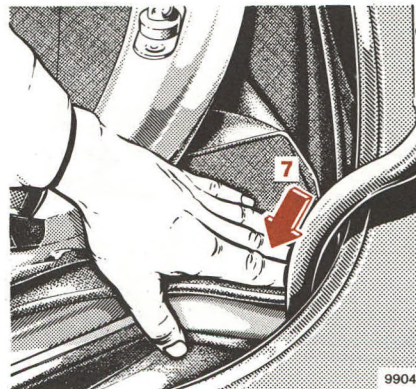
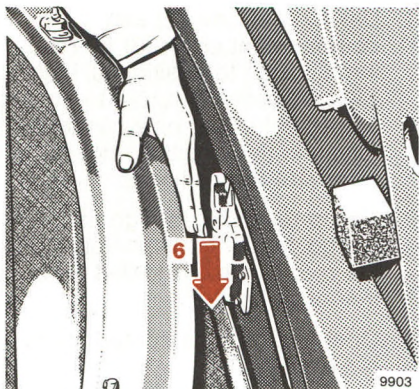

5. Fold back soft top into its storage compartment (5). To avoid curling the edges of the soft top, tuck in so that the material is not stored with lifted edges.

- (6) under lock,
- (7) under the left and right hinge area,
- (8) at the left and right side area.

6. Close top storage compartment cover, making sure that both sides (9) are locked.

### Raising the soft top:

1. Rotate lever (1) to position C and open storage compartment cover (3).
2. Pull top out of compartment and rest top framework against windshield header bar.

3. While pulling top down tighten framework by turning locks (4) outwards. Remove locking handles.

4. Close storage compartment cover, making sure that both sides are latched.
5. Rotate lever (10) to position D, fold down rear bow until pin locks in place, then tighten with crank (1) (position A).



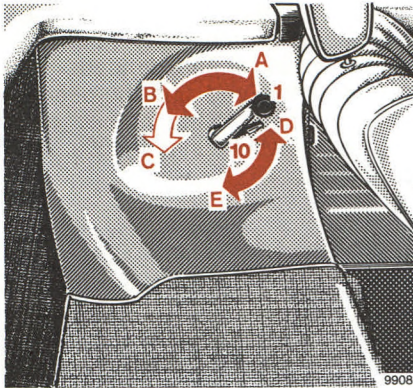

Removal or attachment of the hardtop is best done in a MERCEDES-BENZ service station, although this can be carried out by 2 persons.

The soft top must be completely dry before it is placed in the storage compartment.

To remove or attach the hardtop, find two locking handles in a bag stowed in the glove compartment.

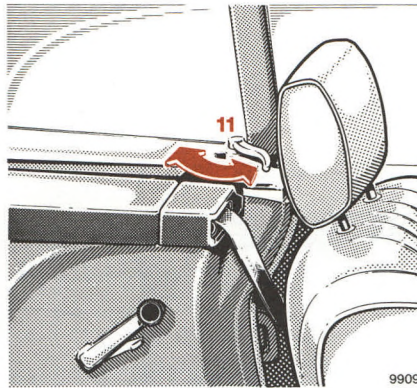

They are used to engage or disengage the locks in windshield header bar and behind the doors (11). Put locking handles back into the glove compartment after use.

The hardtop is secured at 5 attachment points:

Front = two locks in windshield header bar

Side = one lock behind each door (11)

Rear = bow lock

Removal of hardtop:

1. Disconnect plug and socket of the heated rear window in the R-H rear compartment.
2. Place lever (1) in position B, lever (10) in position E.
3. Turn side locks (11) rearwards to the stop with locking handles.
4. Insert locking handles into windshield header bar locks and turn inwards. Remove locking handles.
5. With one person on each side, first lift at rear, then at front and carry top rearward off vehicle.
6. Return lever (1) to position A, lever (10) to position D.

## Hardtop

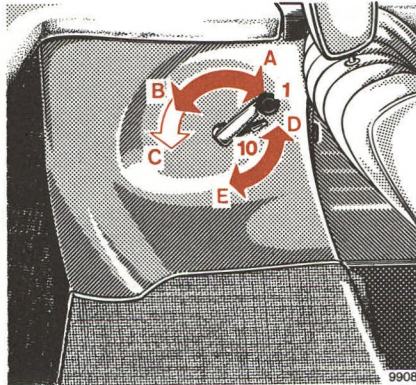

### Attaching hardtop:

1. Move lever (1) to position B and lever (10) to position D.
2. Install hard top with caution to avoid paint damage. Lower hard top slowly. Engage rear pin first then forward pins.

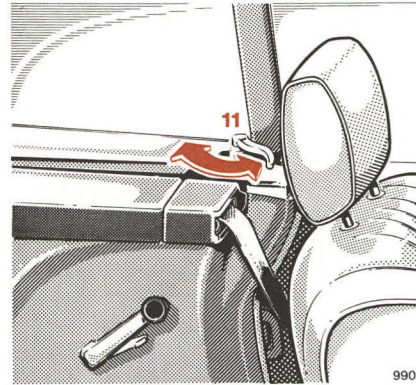

3. Insert both locking handles into the forward locks and swing outwards.
4. Insert locking handles into side locks (11) and turn completely forward to the stop.
5. Move lever (1) to position A.
6. Connect plug and socket of the heated rear window in the R-H rear compartment.

The soft top may become moldy if it is kept enclosed in the storage compartment for an extended period. Unfold and air it thoroughly (do not expose to the sun) at regular intervals during the wet and cold seasons.

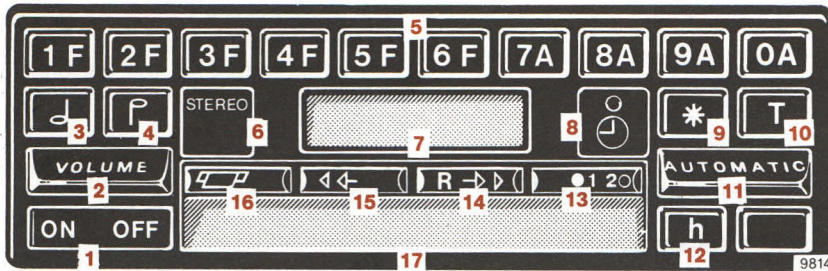

### Electronic Radio

- |   |  |
|---|--|
| <p>1 On/Off switch <b>ON OFF</b></p> <p>2 Volume control <b>VOLUME</b></p> <p>3 Bass control <b>J</b></p> <p>4 Treble control <b>F</b></p> <p>5 Push buttons for AM/FM band selection, station frequency selection, station presetting <b>1 F</b> through <b>0A</b> and clock setting.</p> <p>6 Stereo indicator light <b>STEREO</b></p> <p>7 Digital display panel for station frequency, station push button number, AM/FM band and time display <b>101.5 MHz 2</b></p> | <p>8 Recessed button for setting time <b>⊖</b></p> <p>9 Function control button <b>*</b></p> <p>10 Timer button <b>T</b> to control switch-on time of radio</p> <p>11 Automatic or manual search station seeker bar <b>AUTOMATIC</b></p> <p>12 Time display call button <b>h</b></p> <p>13 Cassette track switch and track indicator <b>▶ ● 1 2 ◀</b></p> <p>14 Fast tape rewind locking button <b>▶ R ▶▶ ◀</b></p> <p>15 Fast tape forward locking button <b>▶ ◀◀ ◀</b></p> |
|---|--|

16 Cassette eject button **▶▶▶**

17 Cassette door **|||||**

To turn the radio on or off, the ignition switch must be in position "1" or "2".

#### To turn the radio ON

Press "ON" side of **ON OFF** switch.

The radio will begin operating on the last station tuned to and the last volume and tone setting stored before last turn off.

The radio can also be turned on by inserting a tape cassette through the cassette door.

#### To turn the radio OFF

Press the "OFF" side of the **ON OFF** switch.

#### Volume adjustment

To reduce volume, press volume switch **VOLUME** downward; to increase volume, press switch **VOLUME** upward.

## Radio

---

### To adjust the tone characteristic

To set the radio to a “flat” frequency response, briefly press both tone controls **⏮** **⏭** simultaneously.

To produce more bass, press the bass control only **⏮**. To produce more treble, press the treble control only **⏭**.

#### Note:

Repeated pressing of either the bass or treble control will cause the respective tone control to alternate between an increasing and decreasing setting.

### To select AM or FM

Press any of the buttons marked **1F** through **6F** to tune the radio to the FM band.

Press any of the buttons marked **7A** through **0A** to tune the radio to the AM band.

### To tune to a station

Stations can be tuned in by using automatic search, direct frequency dialing, manual tuning, or by preset push buttons. The frequency of the station selected is displayed digitally on the display panel.

#### Automatic station search

Switch to the wave band desired by pressing any of the following buttons:

for FM, buttons **1F** through **6F**,  
for AM, buttons **7A** through **0A**.

By pressing the automatic station seeker bar **AUTOMATIC** upward the radio will search for stations in ascending frequencies, by pressing down in descending frequencies. The direction of automatic searching can be reversed by pressing

the bar **AUTOMATIC** in the respective direction. In order to arrive at a desired station faster, the bar has to be held down in the desired direction.

The radio is programmed to automatically search the entire band in three sensitivity modes. During its first sweep, only the most powerful stations received will be selected and locked in. During the next sweep, the less powerful and during the third cycle, also the weak stations will be locked in.

If the station seeker bar is activated within 8 seconds after the radio is tuned to a station, then the search operation will be continued at the same sensitivity level. If 8 seconds are exceeded, the radio will revert to searching only the most powerful stations.

### Direct frequency dialing

In order to select a station with a known frequency, select the wave band, press the function button **\*** and then enter the frequency by pressing the corresponding push buttons.

Example:

FM 98.5 MHz	AM 1050 KHz
<b>1 F</b> through <b>6 F</b>	<b>7 A</b> through <b>0 A</b>
<b>*</b>	<b>*</b>
<b>9 A</b> <b>8 A</b> <b>5 F</b>	<b>1 F</b> <b>0 A</b> <b>5 F</b> <b>0 A</b>

Press any button marked  
Press the function button  
Enter frequency by pressing

When dialing a frequency directly, the number of the push buttons is not displayed on the panel. The wave band is indicated by showing “MHz” for FM or “KHz” for AM.

Note:

All AM stations have allocated frequencies ending with a “0”.  
All FM stations have allocated frequencies ending with an odd (uneven) digit after the decimal point.

Broadcasters sometimes may not give their exact frequency but the next closest even number.

US radio frequency ranges: AM 540 – 1600 KHz  
FM 88.1 – 107.9 MHz

**Manual tuning** (used to fine tune a station or for manual scanning)  
After selecting the desired AM or FM wave band, press the function control button **\***.

Press automatic station seeker bar **AUTOMATIC** (up or down) and hold down. The frequency will increase or decrease respectively in increments of 0.1 MHz for FM or 1.0 KHz for AM. Release the button when the desired station is tuned in.

Unless the automatic station seeker bar **AUTOMATIC** is activated within 8 seconds after pressing the function control button **\***, the manual tuning will automatically be deactivated.

### Safety Note

To avoid distraction of attention from the vehicle’s operation and the road, it is recommended NOT to perform any manual dialing operations by the driver while the vehicle is in motion. Use the automatic station search operation or preset stations instead.

### Push button tuning

Six FM stations and four AM stations can be stored in memory and recalled by pressing the appropriate buttons marked **1 F** through **6 F** for FM or **7 A** through **0 A** for AM stations.

### To store stations in memory

Any FM station frequency displayed on the panel can be stored on any button marked **1 F** through **6 F** by depressing the button desired and holding it until the display has changed from the “old” setting to a “blank” and then to the new frequency to be stored.

## Radio

Showing the “old” setting first allows for reconsideration of the decision to store. If it is desirable to leave the “old” frequency in memory rather than exchanging it with the “new” one, quickly release the button. The “old” frequency will remain in memory.

Any AM station can be stored similarly on any button marked **7A** through **0A**.

### Stereo reception

The stereo indicator symbol **STEREO** lights up if a stereo program is received.

The radio is equipped with an automatic stereo/mono switch that electronically switches to mono for clear reception if a weak signal is received. A special circuit provides for a smooth change-over rather than a hard sudden switching, thereby reducing noise and interference.

The stereo indicator will remain lit even if the receiver has changed to the mono mode and will turn off at an antenna signal considered insufficient to provide acceptable reception quality.

### Tape Cassette playback



It is recommended to use only good quality cassettes with a playback time of not more than 60 to 90 minutes (C 60) or (C 90).

To start playback, insert a cassette through the cassette door. Push the cassette in until it is locked in its playing position.

When the end of one playing side is reached, the unit switches automatically to reverse for playing the second track.

Manual reverse can be activated by depressing the cassette track switch button . The built-in indicators show the track of the cassette the unit is playing back.

To stop playback, press the eject button . The unit will automatically eject the cassette and switch to radio reception.

For fast tape rewind press the fast rewind button . The button will lock into position until the end of the tape is reached or until the eject  or fast forward  button is activated.

Accordingly, for fast forward transport of the tape, press the fast forward button .

When the radio is turned off by pressing the “OFF” side of the **ON OFF** switch or by turning the ignition key off, the cassette will automatically be ejected.

### Care and maintenance

To avoid a deterioration of the tone quality, occasionally clean the tape head with the special cleaner supplied in your glove compartment or available through your dealer.

### To set clock

Turn ignition key to position “1” or “2”.

Briefly press recessed time set button  by using a pencil or ballpoint pen.

Enter the time at which you want to start the clock by sequentially pressing four of the top row push buttons **1F** through **0A**. The time entered will be displayed.

**Note:**

This is a 24 hour clock and time must be entered in all four digits. A 24 hour clock counts time from midnight to midnight, that is 24 hours. A time of 4:28 PM therefore is counted by this clock as 16:28 hours (12 plus 4:28 hours).

Example 1: To enter 7:30 AM,  
press buttons  
**0A** , **7A** , **3F** , **0A**

Example 2: To enter 4:28 PM,  
press buttons  
**1F** , **6F** , **2F** , **8A**

The time entered is now stored. To start the clock in accordance with a time signal or other time reference, again briefly press the recessed time set button **⏸**.

A colon sign will appear between the second and third digits **07:30**, to indicate that the clock is activated.

Normally, the display panel will show the frequency the radio is tuned to.

**To display time**

Briefly press the call button **h**. The time will be displayed for a few seconds.

**To use the timer **T****

By using the timer **T**, the radio can be automatically turned on at a preset time. In order to set the timer **T**, the ignition key must be in position "1" or "2". The timer **T** can only turn the radio on with the ignition switch in position "1" or "2".

**Setting the timer**

Press button **T** and key the desired turn-on time into the timer as explained under "setting of the clock." In order to start the timer, for instance, to turn the radio on at a preset time, press button **\***. The fact that the timer has been started is shown by displaying a colon between the second and third digits of the time.

Whenever you wish to verify the time at which the timer is set, press button **T**. The time will be displayed in the panel. After a few seconds, the display will switch back to the station frequency. In order to change the timer to a new setting, refer to the above information.

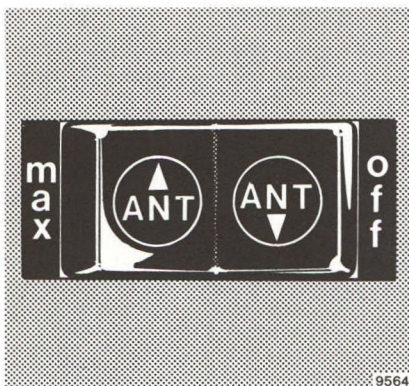

### Automatic Antenna

The antenna switch can be actuated with the radio switched on and the key in steering lock positions "1" or "2".

- If the antenna switch is in the center position, the antenna extends automatically to medium height,
- if the antenna switch is engaged in the "max." position, the antenna extends fully,
- if the antenna switch is engaged in the "off" position, the antenna will not extend or will retract completely.

The height of the antenna can be adjusted to any intermediate height by actuating the antenna switch:

- If the antenna switch is in the center position, the antenna will extend to medium height. The antenna can be further extended or retracted to any height by rocking the switch (not engaging it).
- If the antenna is to be retracted, e.g. for playing cassettes, engage switch in "off" position.

When the key is turned to steering lock position "0" or the radio is turned off, the antenna will retract completely.



# Driving

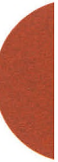

## Hood

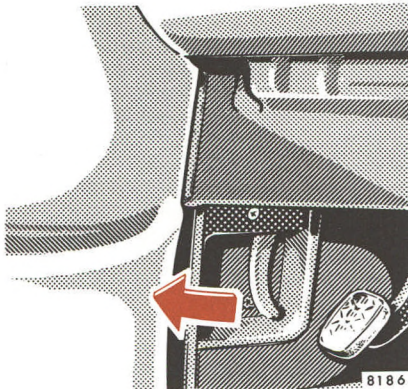

Pull lever below L-H side of instrument panel to unlock the hood. The hood opens to the safety catch stop. Pull lever in radiator grille as indicated by the arrow and lift hood (windshield wiper arms must not be folded out).

To close, press down hood firmly.

### Warning:

Stay clear of moving parts when hood is open and the engine is running.

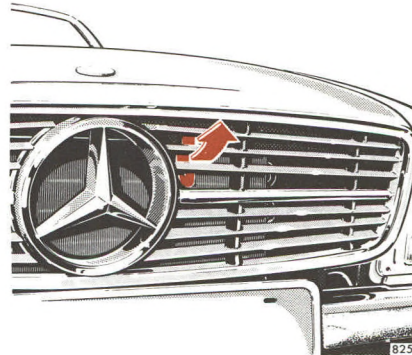

The engine is equipped with a transistorized ignition system. Because of the high voltage it is highly dangerous to touch any components (ignition coil, distributor, spark plug sockets, ignition cables, diagnostic socket) of the ignition system

- if the ignition is "on" and the engine revved manually
- while starting the engine
- with running engine

## Parking Brake

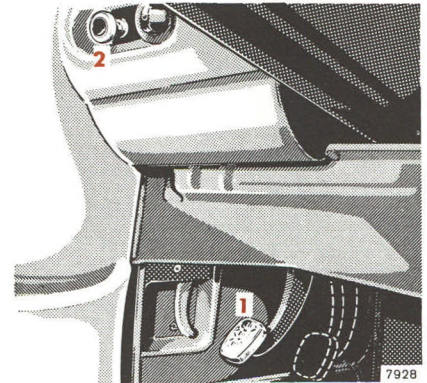

Depress parking brake pedal (1). When the steering lock key is in position "2", the brake warning lamp in the instrument cluster comes on.

To release, pull release button (2) on the instrument panel. The parking brake releases in one rapid movement. The parking brake warning lamp in the instrument cluster must go out.

Have the following items checked regularly and prior to any long trip

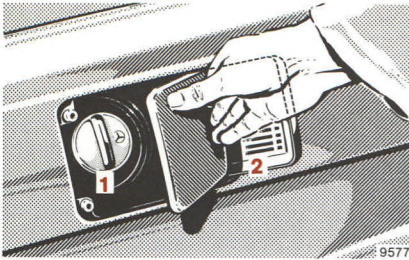

9577

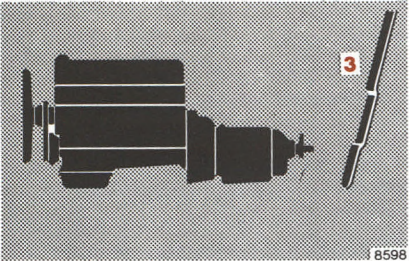

B598

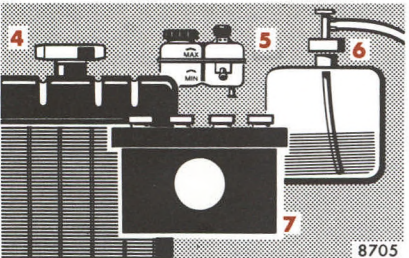

8705

**1 Fuel Supply**

Use unleaded gasoline, for octane rating see "Capacities" and last page.

**2 Tire Pressure**

For tire pressure table refer to fuel filler flap or last page. Check at least every other week. For more details see "Wheels, Tires, Changing Wheels".

**3 Oil/Fluid Level: Engine, Automatic Transmission**

See "Checking Fuels, Coolants, Lubricants, etc.", "Fuels, Coolants, Lubricants, etc." and last page.

**4 Coolant Level**

See "Checking Fuels, Coolants, Lubricants, etc.", "Fuels, Coolants, Lubricants, etc." and last page.

**5 Brake Fluid**

When the minimum mark on the reservoir is reached, have the system checked (brake lining thickness, leaks).

**6 Windshield Washer**

Replenish with windshield washer solvent (container is in the engine compartment).

**7 Battery**

Replenish with distilled water only. See "Electrical System".

**Vehicle Lighting**

Check for function and cleanliness.

## Catalytic Converter Cautions

---



Your MERCEDES-BENZ is equipped with monolithic catalytic converters, an important element in conjunction with the O<sub>2</sub>-sensor to achieve substantial control of the pollutants in the exhaust emissions. Keep your vehicle in proper operating condition by following our recommended maintenance instructions as outlined in your maintenance booklet.

Should any noticeable irregularities in the engine operation occur such as misfiring of one or more cylinders, indicated by audible signs, excessive unburned fuel may reach the converter causing it to overheat.

Continued operation of your vehicle can result in damage to the converter.

### **For the same reason we caution against:**

- Misuse or abuse of your vehicle engine
- Refueling with leaded gasoline
- Excessive idling with cold engine
- Push or tow starting your vehicle with hot engine.

As with any vehicle, do not idle, park or operate this vehicle in areas where combustible materials such as grass, hay or leaves can come into contact with a hot exhaust system, as these materials could be ignited.

We urge your cooperation by following the above instructions to achieve cleaner air.

Engage parking brake and move the gear selector lever in either “P” or “N” position before starting the engine.

Turn key in steering lock to position “2”. The charge indicator lamp must come on.

### Cold Engine

Turn key in steering lock clockwise to the stop. Do not depress accelerator. Release key only when the engine is firing regularly.

At ambient temperatures of less than  $-18^{\circ}\text{C}/0^{\circ}\text{F}$ , depress accelerator three times prior to starting.

### Hot Engine

Turn key in steering lock clockwise to the stop. Do not depress accelerator. If the engine has not fired after approx. 4 seconds, depress accelerator and continue cranking until the engine is firing regularly. Release key and back off accelerator.

### Turning off

Turn the key in the steering lock to position “0” and only remove the key when the vehicle is at standstill.

If the coolant temperature is very high (e.g. after hard driving on mountain roads), do not shut off the engine immediately but allow it to run on for 1–2 minutes at increased idle speed.

### Hints

Due to the installed starter non-repeat unit, the key in the steering lock must be returned to “0” position before a new starting attempt is made.

Observe the oil pressure gauge immediately after starting the engine. In a very cold engine the oil pressure will only rise slowly, some time after the engine has started.

Do not speed up the engine before pressure is registered on the pressure gauge.

The charge indicator lamp must go out as soon as the engine has started.

Should too much fuel have entered the engine due to several unsuccessful starting attempts and the engine will no longer fire, depress the accelerator while starting. In this way the mixture becomes combustible again. Back off the accelerator only when the engine is firing regularly.

In areas where temperatures frequently drop below  $-25^{\circ}\text{C}/-13^{\circ}\text{F}$ , we recommend that a block heater is installed. Every MERCEDES-BENZ service station will advise you on this subject.

## Starting and Shifting Gears

The automatic transmission simplifies the handling of the vehicle. The individual gears are shifted automatically dependent upon selector lever position, vehicle speed and accelerator position.

### Hints

When parking the vehicle or if working on the vehicle with the engine running, depress parking brake pedal and move selector lever to position "P".

### Warning:

Keep driver's foot area clear at all times. Objects stored in this area may cause impairment of pedal movement.

### Driving

Shift selector lever to the desired driving position only when the engine is idling and the service brake is applied. Do not release the brake until ready to drive. The vehicle may otherwise start creeping when the selector lever is in a driving position.

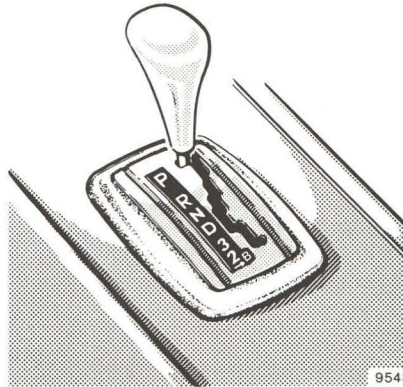

Test service brake after driving off.

Warm up the engine smoothly. Do not place full load on the engine until the operating temperature has been reached.

When taking off on a slippery surface, do not allow one driving wheel to spin for an extended period.

### Accelerator position

Partial throttle = early upshifting  
= normal acceleration

Full throttle = later upshifting  
= maximum acceleration

Depressing the accelerator beyond full throttle to kickdown position means downshifting to the next lower gear and thus maximum acceleration. If you ease up on the accelerator after having attained the desired speed, the transmission will shift up again.

### Selector Lever Positions

The automatic gear shifting process can be adapted to specific operating conditions by means of the selector lever.

"P" Parking lock.

The parking lock is an additional safeguard when parking the vehicle. Engage only with the car stopped.

"R" Reverse gear.

Shift reverse gear only with the car stopped.

### “N” Neutral.

No power is transmitted from the engine to the rear axle. When the brakes are released, the vehicle can be moved freely (pushed, towed or tow-started). Do not engage “N” when driving except when the vehicle is in danger of skidding (e.g. on icy roads, see page 50).

### “D” Drive.

All forward gears are available. The vehicle starts off in 1st gear. Position “D” affords optimum driving characteristics under all normal operating conditions.

### “3” Upshift to 3rd gear only.

OK for medium range up or downgrades.

### “2” Upshift to 2nd gear only. For driving in mountainous regions.

Since transmission will not shift up further, this gear selection will make use of the engine’s braking power.

“B” In this position, the engine’s braking effect is utilized while descending steep or lengthy downgrades, especially with a trailer. Use this position only below 60 km/h/40 mph.

### Important!

Do not exceed the speed limits for individual gear selections, which are correspondingly indicated by marks on the speedometer.

Do not attempt downshifting to a lower gear unless the speedometer needle is below the speed-limit-mark of that particular gear range. Over-revving could otherwise result in damage to the engine.

On slippery road surfaces, it is not recommended to downshift in order to obtain braking action.

### Trailer Operation

When proceeding on a hill, do not allow the engine RPM to drop off too low. Shift the gear selector well in advance, depending on the degree of incline or decline, to position “3” or “2”.

### Stopping

When stopping, e.g. at a traffic light, hold vehicle with service brake while leaving the transmission engaged; do not hold vehicle by accelerating engine. This will help to avoid unnecessary heat-buildup in transmission. For longer stops with the engine idling, shift into “N” or “P”.

### Maneuvering

To maneuver in tight areas e.g. when pulling into a parking space, control the car speed by gradually releasing the service brake. Accelerate gently and do not pump the accelerator. To rock a car out of soft ground (mud or snow), alternately shift from forward to reverse, apply only partial throttle.

## Safe Driving

---

### Power assistance:

When the engine is not running, both the service brake and the steering are without power assistance. Under these circumstances, a much greater effort is necessary to steer or stop the vehicle.

### Tires:

Do not allow your tires to wear down too far. With less than approx. 3 mm/1/8 in of tread, the antiskid properties on a wet road are sharply reduced.

Depending upon the weather and/or road pavement, the traction varies widely.

Specified tire pressures must be maintained. This applies particularly if the tires are subjected to high loads (e.g. high speeds, heavy loads, high ambient temperatures).

### Aquaplaning:

Depending on the depth of the water layer on the road, aquaplaning may occur, even at low speeds. Avoid track grooves in the road and apply brakes cautiously in the rain.

### Tire friction:

A given speed at which a vehicle driven on dry roads can still be fully controlled must be reduced when the same vehicle is to be driven safely on a wet or icy road.

You should pay particular attention to the condition of the road as soon as the prevailing temperatures fall close to the freezing point.

If ice has formed on the road tire traction will be substantially reduced. Under such weather conditions, drive, steer and brake particularly carefully.

We recommend M+S radial-ply tires for the cold season. On packed snow, they can reduce your stopping distance as compared with summer tires. Stopping distance, however, is nevertheless considerably greater than when the road is wet or dry.

### Brakes:

When driving down long and steep declines, relieve the brakes by shifting into "B", "3" or "2". This prevents overheating of the brakes and reduces brake pad wear.

After hard braking it is advisable to drive on for some time so the air stream will cool down the brakes faster.

When driving in heavy rain for some time without applying the brakes, the first braking action may be somewhat reduced and increased pedal pressure may be necessary. For this reason, stay further away from vehicle in front.



The condition of the parking brake system is checked each time the car is in the shop for maintenance.

Between maintenance checks it is a good practice to apply the parking brake once or twice while driving at approximately 50 km/h/30 mph on a dry road. Apply brake lightly until a slight drag on the wheels is felt. Keep applying brakes for about 10 seconds while pulling release knob out, then release parking brake completely. This practice will keep the parking brake at maximum efficiency.

**Warning:**

The stop lamps will not come on when applying the parking brake only. Apply parking brake only when road behind vehicle is clear of traffic.

All checks and maintenance work on the brake system should be carried out by a MERCEDES-BENZ dealer. If the parking brake is released and the brake warning lamp in the instrument cluster stays on, the brake fluid level in the reservoir is too low.

Brake pad wear or a leak in the system may be the reason for low brake fluid in the reservoir.

Have the brake system inspected at a MERCEDES-BENZ service station without delay.

Install only brake pads recommended by us. If other than recommended brake pads are installed, the braking properties of the vehicle can be affected to an extent that the safety is substantially impaired.

**Brake Pad Wear Indicator Lamp**

The brake pad wear indicator lamp in the instrument cluster comes on when the key in the steering lock is turned to driving position “2” and it must go out when the engine is running. If the indicator lamp lights up during braking, this shows that the front wheel brake pads are worn.

Have brake system checked in a MERCEDES-BENZ service station as soon as possible.

**Brake Fluid**

Brake fluid should be changed once a year, preferably in spring.

Only use brake fluid recommended by us. For further information, refer to “Fuels, Coolants, Lubricants, etc.”.

**Charge Indicator Lamp**

Should the charge indicator lamp fail to come on prior to starting when the ignition key is in position “2” or should it fail to go out after starting or during operation, this indicates a fault which must be repaired at a MERCEDES-BENZ service station as soon as possible.

**Fuel Reserve Warning Lamp**

The fuel reserve warning lamp will come on when the key in the steering lock is turned to position “2”, and will go out after the engine is running.

If the warning lamp stays on after the engine starts, or comes on while driving, it indicates that the fuel level is down to the reserve quantity.

### Oil Pressure Gauge

The oil pressure may drop at idle speed to 0.3 bar/4.4 psi if the engine is at operating temperature. This will not jeopardize its operational reliability. Pressure must, however, rise immediately upon acceleration.

The oil pressure gauge will not provide early warning of low oil level. Therefore, check oil level at regular intervals with the dipstick.

### Coolant Temperature Gauge

Due to the pressurized cooling system, the coolant only starts boiling at a temperature of approx. 125° C/ 257° F with an anti-corrosion/anti-freeze-blended coolant fill protecting down to -30° C/-22° F (see also "Fuels, Coolants, Lubricants, etc.").

During severe operating conditions and stop-and-go city traffic the coolant temperature must not rise above the red marking.

### Emission Control

Certain systems of the engine serve to keep the toxic components of the exhaust gases within permissible limits required by law. (Nevertheless, we urgently advise you not to let the engine run in a closed garage.) These systems, of course, will function properly only when maintained strictly according to factory specifications. Any adjustments on the engine should, therefore, be carried out only by qualified MERCEDES-BENZ technicians. The adjustments of the engine should not be altered in any way. Moreover, the specified service and maintenance jobs must be carried out regularly according to MERCEDES-BENZ servicing requirements. For details refer to the Maintenance Booklet.

### Engine Oil Consumption

Engine oil consumption can only be determined after a certain mileage has been covered. During the break-in period, higher oil consumption may be noticed and is normal.

## The First 1500 km/1000 Miles

---

The more cautiously you treat your engine during the break-in period, the more satisfied you will be with its performance later on. Therefore, drive your vehicle during the first 1500 km/1000 miles at moderate vehicle and engine speeds.

During this period, avoid heavy loads (full throttle driving) and high RPMs (no more than  $\frac{2}{3}$  of maximum permissible speed in each gear).

Avoid accelerating by kickdown. It is not recommended to brake vehicle by means of manually shifting to a lower gear. We recommend to select positions "3" or "2" only at moderate speeds (for hill driving).

After 1500 km/1000 miles speeds may gradually be increased to the permissible maximum.

## Driving Economically

---

### Gauge for Economical Driving (ECONOMY)

The gauge for economical driving indicates the fuel consumption tendency during the various driving modes.

If, while driving, the pointer travels to the right into the red field, this indicates an increase in the momentary fuel consumption.

In order to drive economically you should try to keep the pointer of the gauge away from the red field in all gears, by avoiding hard acceleration as much as possible.

Use selector lever position "D" while driving under all normal operating conditions. Using selector lever positions "3" or "2" can involve an increased consumption of between 25–80 %.

## Special Operating Conditions

---

### Winter Driving

Have your car winterized in a MERCEDES-BENZ service station before the onset of winter.

- Engine oil change: If no "all year round" engine oil is used, fill with recommended winter oil. For viscosity and capacity refer to "Fuels, Coolants, Lubricants, etc." and last page.
- Anti-corrosion/antifreeze in the coolant: Check anti-corrosion/antifreeze protection periodically. For capacity refer to "Fuels, Coolants, Lubricants, etc.".
- Additive in the windshield washer system: Add windshield washer solvent to the water in the windshield washer system.

## Special Operating Conditions

---

- **Test battery:** Battery capacity drops with decreasing ambient temperature. A well charged battery ensures that the engine can always be started, even at low ambient temperatures.
- **Tires:** We recommend M+S radial tires on all wheels for the winter season. Observe permissible maximum speed for M+S radial tires and the legal speed limit.

### Hints for Driving

The most important rule for slippery or icy roads is to drive sensibly and to avoid abrupt acceleration, braking and steering action. Do not use the cruise control system under such conditions.

When the vehicle is in danger of skidding, move selector lever to position "N". Try to keep the vehicle under control by means of corrective steering action.

Provided the traffic conditions will allow, only brake in a way that the wheels are locked for no more than fractions of a second as otherwise the steerability of the vehicle is lost.

Road salts and chemicals can adversely affect braking efficiency. Increased pedal force may become necessary to produce the normal brake effect. We therefore recommend depressing the brake pedal repeatedly when travelling on salt-strewn roads at length. This can bring road salt impaired braking efficiency back to normal. A prerequisite is, however, that this is possible without endangering other drivers on the road.

If the vehicle is parked after being driven on salt treated roads, the braking efficiency should be tested as soon as possible after driving is resumed while adhering to the safety requirements.

### Tire Chains

Use only tire chains that are tested and recommended by us. Any MERCEDES-BENZ service station will be glad to advise you on this subject.

Chains should only be used on the rear wheels. Adhere to the manufacturer's mounting instructions. Remove the wheel covers to mount and retighten chains.

After driving a short distance retighten the mounted chains.

Tire chains should only be driven on snow at speeds not to exceed 50 km/h/30 mph. Remove chains as soon as possible when driving on roads without snow.

### Traveling Abroad

Abroad, there is a widely-spread MERCEDES-BENZ service network at your disposal. If you travel into areas which are not listed in the index of your service station booklet, you should request pertinent information from your dealer.

# Vehicle Care



A maintenance booklet is delivered with your car listing all the maintenance jobs that must be carried out after the following mileages:

### Routine Maintenance

Inspection at

1300–1600 km/800–1000 miles

Lubrication Service every

12 000 km/7500 miles

Maintenance Service every

24 000 km/15 000 miles

Additional Work every

48 000 km/30 000 miles

In the case of low mileage operation, the Maintenance Service must be carried out at least once every 2 years.

### Engine Oil and Filter Change

Required every 12 000 km/7500 miles, or at least once a year when using year-round multigrade oil; otherwise at least twice a year (spring and fall).

For engine oil recommendations, see page 76.

### Severe Operating Conditions

In the case of severe operating conditions or heavy use mainly in city traffic or over short distances, frequent mountain driving, poor roads, dusty and muddy conditions, trailer operation, hard and sporty driving etc., it may be necessary to carry out maintenance work at shorter than normal intervals, e.g.:

Engine: Oil change with filter change every 6000 km/3750 miles

Automatic transmission: Fluid change without filter change every 24 000 km/15 000 miles

Tires: Inspect

Air cleaner: Clean or renew element

### Non-scheduled MB Maintenance Service

Every 24 000 km/15 000 miles Maintenance Service consists of 3 sections (General and Lubrication Service, Engine Maintenance, Safety Inspection). Performance of these sections can be requested individually if particular driving conditions so require, or on a precautionary basis before leaving for a long trip.

### Special Maintenance Measures

**Brake fluid** should be renewed annually, preferably in spring.

**The coolant** should be checked for sufficient protection before the start of and during the cold season. Have the coolant (water/anti-corrosion/antifreeze mixture) renewed not later than after three years (see “Fuels, Coolants, Lubricants, etc.”).

### Maintenance Vouchers

Your MERCEDES-BENZ service station will certify in the maintenance booklet that all lubrication and maintenance services have been carried out at the correct intervals.

**Stickers** to remind you when the next lubrication service or maintenance service is due, or when the brake fluid must be changed, are provided in the middle of the maintenance booklet.

Sticker attaching points

In the frame of the driver's door:

Lubrication service and maintenance service

In the engine compartment:

Brake fluid change

## Spare Parts Service

---

All MERCEDES-BENZ service stations maintain a stock of original spare parts required for maintenance and repair work. In addition, strategically located parts distribution centers provide quick and reliable parts service. More than 200000 different spare parts, even for rather old vehicle models, are available.

MERCEDES-BENZ original spare parts are subjected to most severe quality inspections. Each part has been specifically developed, manufactured or selected for and adapted to MERCEDES-BENZ vehicles.

Therefore, MERCEDES-BENZ original spare parts should be installed.

## Cleaning and Care of the Vehicle

---

In operation, your vehicle is subjected to a great amount of varying external influences which, if gone unchecked, can attack the paintwork as well as the underbody and cause lasting damage.

Such damage is caused not only by extreme and varying climatic conditions, but also by air pollution, road salt, tar, gravel and stone chipping. Grease and oil, fuel, coolant, brake fluid, bird droppings, tree resins, etc. should be immediately removed to avoid paint damage. Frequent washing, however, reduces and/or eliminates the aggressiveness and potency of the above adverse influences.

More frequent washings are necessary to deal with unfavorable conditions; for example, near the ocean, in industrial areas (smoke, exhaust emissions), or during winter operation.

You should check over your vehicle from time to time for stone chipping or other damage. Any damage should be repaired as soon as possible to prevent the start of corrosion.

In doing so, do not neglect the underside of the car. A prerequisite for a thorough check is a washing of the underbody followed by a thorough inspection. Damaged areas need to be re-undercoated.

Your vehicle has been treated at the factory with a wax-base rust-proofing in the body cavities which will last for the lifetime of the vehicle. Post-production treatment is neither necessary nor recommended by MERCEDES-BENZ because of the possibility of incompatibility between materials used in the production process and others applied later.

After every engine cleaning you should have the engine compartment re-rustproofed. Before rust-proofing, all control linkage bushings have to be lubricated with hydraulic oil (check with your local MERCEDES-BENZ dealership for recommended brands).

We have selected car-care products and compiled recommendations which are specially matched to our vehicles and which always

## Cleaning and Care of the Vehicle

---

reflect the newest in technological standing. You can obtain MB car-care products at every MERCEDES-BENZ service station.

Scratches, corrosive deposits, corrosion or damage due to negligent or incorrect care cannot always be removed with the car-care products recommended here. In such cases it is best to seek aid at your MERCEDES-BENZ service station.

The following topics deal with the cleaning and care of your vehicle and give important “how-to” information as well as references to recommended MB car-care products.

### Car Washing

Before washing your vehicle, remove insect residues. The car should not be washed in the sun. Use only a mild car wash detergent, such as MB auto shampoo.

Thoroughly spray the car with a diffused jet of water. Direct only a very weak spray towards the ventilation intake. Use plenty of water

and rinse the sponge and chamois frequently. Rinse with clear water and thoroughly wipe dry with a chamois.

If the vehicle has been run through an automatic car wash – in particular one of the older installations – rewipe the recessed sections provided in the tail lamps (for improved prevention of soiling) if necessary. No solvents (fuels, thinners etc.) must be used.

In the winter, thoroughly remove all traces of road salt as soon as possible.

When washing the car underbody, do not forget to clean the inner sides of the wheels.

### Tar Stains

Quickly remove tar stains before they dry and become more difficult to remove.

### Window Cleaning

Use a window cleaning solution on very dirty or oil-stained windows. Clean windshield wiper blades with

a clean cloth and detergent solution. Replace blades at least once or twice a year. Use only mild detergent on the soft top windows.

### Plastic Parts, Headliner, Rubber Parts and MB-Tex Upholstery Covers

Do not use oil or wax on these parts.

### Seat Belts

The webbing must not be treated with chemical cleaning agents. Use only clear, lukewarm water and soap. Do not dry the webbing at temperatures above 80° C/176° F or in direct sunlight. Never bleach or re-dye the webbing.

### Steering Wheel, Instrument Cluster and Selector Lever

Use a gentle dish-washing detergent or mild detergent for delicate fabrics as a washing solution. Wipe with a cloth moistened in lukewarm solution. Do not use scouring agents.



### Upholstery

Leather: Wipe leather upholstery with a damp cloth and dry thoroughly. Exercise particular care when cleaning perforated leather as its underside should not become wet.

### Paintwork

Do not apply wax if your car is parked in the sun or if the hood is still hot. For maximum protection, the paintwork should be waxed approximately once every three months. Use the appropriate MERCEDES-BENZ Touch-Up Stick for quick and provisional repairs of minor paint damage.

### Light Alloy Wheels

If possible, clean wheels once a week with lukewarm water and autoshampoo (or MB Cleaner/Preserver). Use an ample supply of water.

To remove stubborn marks, use polish or paint cleaner and apply with buffing cloth or a soft cloth.

### Ornamental Moldings (Chrome-Plated, Aluminium)

For regular cleaning and care of very dirty chrome-plated parts, use a chrome cleaner.

### Soft Top

Stow only a completely dry top in the storage compartment. If the top is kept in the storage compartment for a lengthy period, unfold and air it well with the windows down from time to time.

Remove bird droppings immediately. The organic acid damages the material and causes the top to leak.

In general, regular spraying or cleansing with clear water will do. Wash top only when heavily soiled, not every time the car is washed.

Caution: Never use any gasoline, thinner, tar and stain removers or similar organic solvents to clean top or rear window.

Dry cleaning:

Brush top (always from front to rear) with a soft-bristled brush.

Wet cleaning:

Brush the dry top. Wash with a mild detergent and an ample supply of lukewarm water by wiping with a soft-bristled brush or a sponge from front to rear. Then cleanse thoroughly with clear water.

If only parts of the top have been washed, wet the entire top at the end of the proceedings and allow the unfolded and tightened top to air-dry. Wipe the rear window with a cloth soaked with a detergent and rub dry. Do not use sharp-edged instruments for the removal of ice and snow.



# Practical Hints

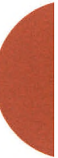

## Practical Hints

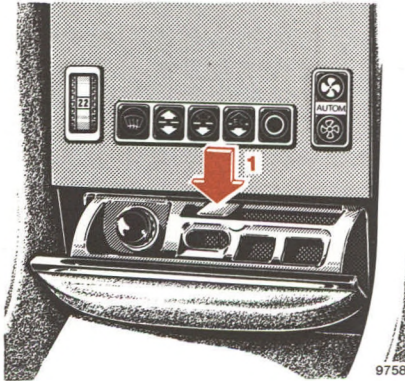

### Ash tray

Removal of ash tray:  
Pull out ash tray up to the stop.  
Depress center locking spring (1)  
and remove ash tray.

To install ash tray:  
Position ash tray squarely and  
push in.

### Luggage or Ski Racks

We recommend the use of drip rail mounted ski and roof racks. This type of rack does not require additional supports (suction cups or legs). Such supports may lead to marring of the paint or even denting of the roof if excessive weight is placed on the rack. Your MERCEDES-BENZ dealer can give further advice.

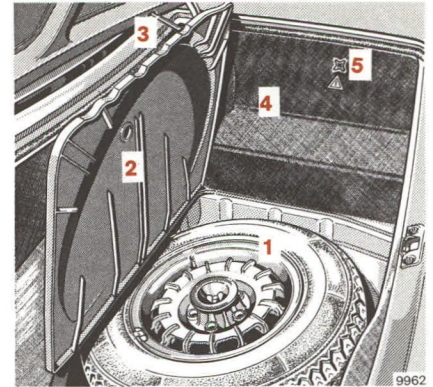

### Spare Wheel, Jack, Vehicle Tool Kit

The spare wheel (1) is stored in a compartment below a hinged cover (2) in the trunk floor.

To raise cover, roll back the floor mat and engage holding strap (3) in the trunk lid.

Open cover (4) by turning latch (5) fully to the left.

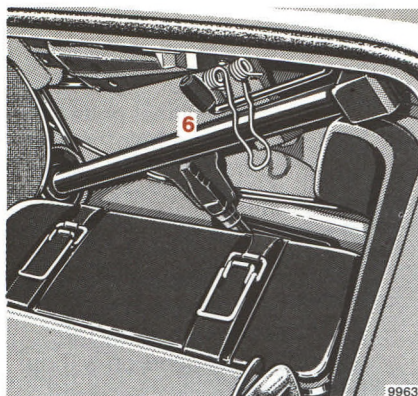

The jack (6) and tool kit are located behind cover (4).

### Caution:

Use the jack only to lift the vehicle during a tire change. Never get beneath the vehicle while it is supported only by the jack. Use jack stands to work under the car.

### Wheels, Tires

In case of replacement we recommend you use tires and rims of identical design, version and brand.

See any MERCEDES-BENZ service station for information on tested and recommended wheels and tires for summer and winter operation. They will also offer more advice concerning tire service and purchase.

Front tires should be replaced in sets. If possible, the spare tire should be used on the rear wheels. We recommend that you break in new tires for approx. 100 km/60 miles at moderate speed.

After a wheel change it is imperative that the wheel mounting bolts be retightened after approx. 800 km/500 miles. On new vehicles retightening is carried out in the course of the 1st inspection. Retightening is also necessary when new wheels are fitted at a later date, e.g. when the spare wheel is used for the first time or when a new set of wheels with M+S tires is fitted.

For tire specifications, refer to "Technical Data".

### Rotating wheels:

The wheels can be rotated according to the degree of tire wear while retaining the same sense of rotation. Rotating, however, should be carried out before the characteristic tire wear pattern (shoulder wear on front wheels and tread center wear on rear wheels) becomes visible at a mileage of 5000–10 000 km/3000–6000 miles as otherwise the driving properties deteriorate.

Slowly leaking air (e.g. due to a nail in the tire) may cause damage to the tire such as tread separation. Regular tire pressure checks at intervals of no more than 14 days are therefore essential. For the tire pressure checks, keep in mind that hot tires show higher pressure than cold tires. See tire pressure chart on last page.

Should the tire pressure decrease constantly, check whether foreign objects have penetrated the tire or if the rim or valve allows air to leak.

Thoroughly clean the inner side of the wheels any time you rotate the wheels or wash the vehicle's underside.

Dented or bent rims cause tire pressure loss and damage to the tire beads. For this reason, check rims for damage at regular intervals.

The rim flanges must be checked for wear before a tire is mounted. Remove burrs, if there are any.

### Changing Wheels

1. Set parking brake.
2. Move selector lever to position "P".
3. Prevent vehicle from rolling away by blocking wheels with wheel chocks: When changing a wheel on a hill, place chocks behind each wheel of the axle opposite to the axle to be worked on; on a level road, place one chock in front and one behind of the

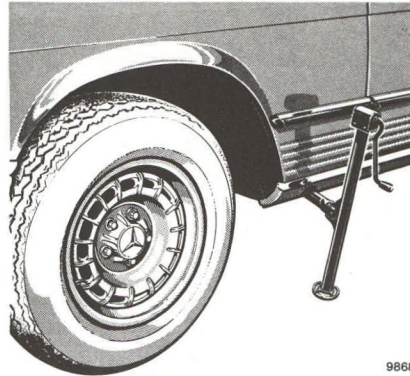

wheel that is diagonally opposite to the wheel being changed.

4. Using the combination wrench, loosen but do not yet remove the wheel bolts.
5. Clean jack supporting tube, if necessary. (Jack tubes are behind the front wheel housings and in front of the rear wheel housings.)
6. Insert jack arm fully into the tube hole up to the stop. Position the jack so that it will always be vertical as seen from the side, even

on inclines. Jack up the vehicle until the wheel is clear off the ground.

7. Then unscrew wheel bolts completely. Keep bolt threads protected from dirt and sand. While removing last bolt, hold wheel against axle to avoid paint damage on rim.
8. Remove wheel.
9. Adjust the jack to allow the wheel to be slipped on without being lifted.
10. Slip on spare wheel and press against wheel mounting flange. Screw in wheel bolts. To avoid paint damage, place wheel flat against hub and hold it there while installing first wheel bolt.
11. Lower car and remove jack. Tighten the five bolts evenly by tightening every other bolt until all the bolts are tight. Observe a tightening torque of 110 Nm/ 80 lb-ft.
12. Correct tire pressure.

### Tire Inflation Pressure

A table (see fuel filler flap or last page) lists the tire inflation pressures specified for summer and winter tires as well as for the varying operating conditions.

Important!

Tire pressure differs by approx. 0.1 bar/1.5 psi per 10° C/18° F of air temperature change. Keep this in mind when checking tire pressure inside a garage – especially in the winter.

Example:

Room temperature = approx. +20° C/+68° F

Ambient temperature = approx. 0° C/+32° F

Adjusted air pressure = specified air pressure +0.2 bar/3 psi.

Tire temperature and pressure increase with the vehicle speed. Tire pressure should therefore only be corrected on cold tires. Correct tire pressure in hot tires only if pressure has dropped below the data listed in the table and the respective operating conditions are taken into consideration.

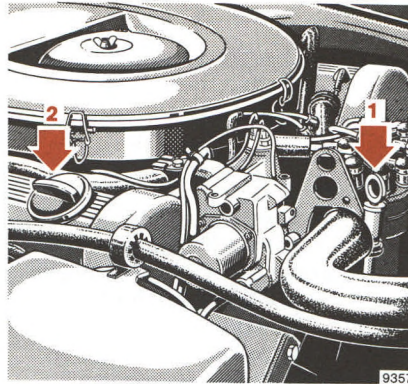

### Engine Oil Level Check

- 1 Dipstick
- 2 Oil filler cap

Check engine oil level at regular intervals, after refueling, with the engine at operating temperature and shut off.



The vehicle should be parked on level ground and the oil level must be somewhere between the lower and the upper mark on dipstick (1); do not add in excess of the upper mark.

Wipe dipstick before any oil level measurement. To determine the oil level, check both sides of the dipstick. Always determine an accurate oil level by means of the straight horizontal marking formed by the oil on one side of the dipstick.

For viscosity and capacity, see “Fuels, Coolants, Lubricants, etc.” and last page.

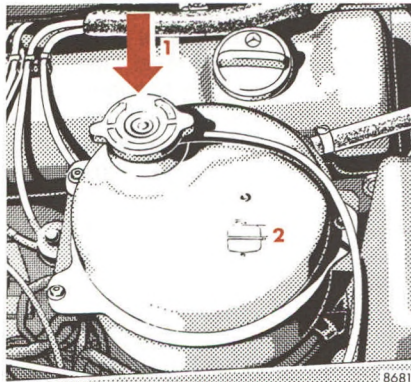

- 1 Coolant Filler
- 2 Marking for coolant level

### Checking Coolant Level

The coolant reservoir with filler neck is arranged away from the radiator. To add coolant, the car must be on level ground.

#### Warning:

Do not remove pressure cap on coolant reservoir if engine temperature is above 90° C/194° F. Allow engine to cool down before removing cap. The coolant reservoir contains hot water and is under pressure.

Using a rag, turn cap to first notch to relieve excess pressure. If opened immediately, hot scalding fluid and steam will be blown out under pressure.

If a small amount of coolant has to be added (due to evaporation of water), plain water can be used.

If a larger quantity of coolant has to be added, a 50/50 mixture of water and anti-corrosion/antifreeze should be used:

The coolant level must reach:

- the mark indicated on the reservoir when the coolant is cold
- approximately 2 cm/0.8 in higher when the coolant is hot

The drain plugs are situated on the R-H and L-H engine side and on the radiator bottom.



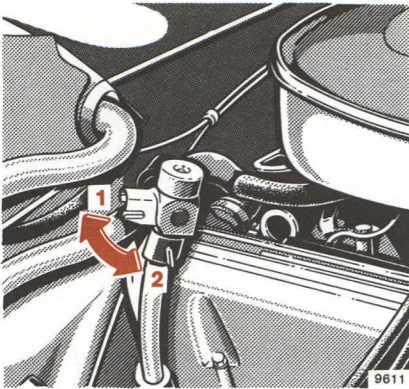

### Automatic Transmission Fluid Level

At regular intervals and prior to a long trip, check automatic transmission fluid level and engine oil level.

Check transmission fluid level with the engine idling, parking brake engaged and selector lever in position "P". The vehicle must be parked on level ground. Prior to the check, allow engine to idle for approx. 1 to 2 minutes.

Measure fluid level with the dipstick completely inserted and the locking lever released (1).

Extreme cleanliness must be observed! To wipe the dipstick, use a clean, lintfree cloth. To fill the transmission with fluid, only pour it through a fine-mesh filter into the dipstick opening. Even the slightest impurity may cause operational troubles.

The fluid level in the transmission is dependent upon its temperature. The maximum and minimum fluid level marks on the dipstick are

applicable references only if the transmission fluid has reached its normal operating temperature of 80° C/176° F.

If the transmission fluid cools down to 20–30° C/68–86° F, which is the normal shop temperature range, then the maximum fluid level will be approximately 5 mm/0.2 in below the minimum mark on the dipstick. We stress this point because a fluid change is normally performed when the transmission fluid has cooled down to shop temperature.

The fluid level must not exceed the dipstick maximum mark with the fluid at operating temperature. Drain or siphon off excess fluid, if required.

Then push dipstick all the way in and swing locking lever downwards (2).

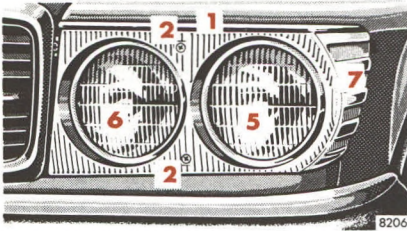

### Headlamp Adjustment

Correct headlamp adjustment is extremely important. Check and readjust headlamps at regular intervals and invariably when a lamp has been replaced.

### Replacing Bulbs

To remove, push the bulb in and turn to the left, then lift the bulb out.

To install, grip the bulb with a paper tissue or similar cloth, align the pins on the base of the bulb with the grooves in the bulb socket, push in lightly and turn to the right until the stop is felt.

Install only 12 volt bulbs with the specified watt rating.

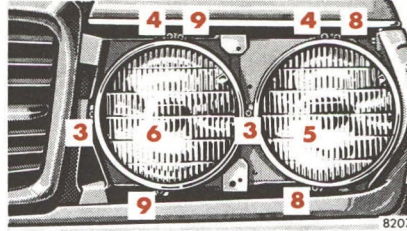

### Front Lamps

- 1 Cover
- 2 Securing screws for cover
- 3 Horizontal adjusting screws
- 4 Vertical adjusting screws
- 5 High and low beam sealed-beam unit (Sealed-beam/Halogen) type 2:  
Loosen clamping screws (8), remove retaining ring and unit, disconnect plug and socket on unit.

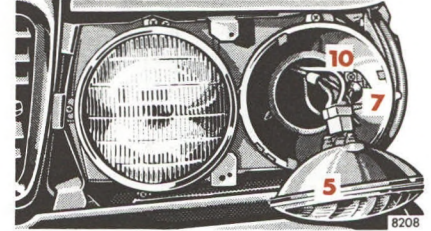

- 6 High beam sealed-beam unit (Sealed-beam/Halogen) type 1:  
Loosen clamping screws (9), remove retaining ring and unit, disconnect plug and socket on unit.
- 7 Side marker lamp (4 W/2 cp):  
Remove unit (5), loosen clamping screw (10) and detach lamp holder. Depress bulb, turn left and pull out.

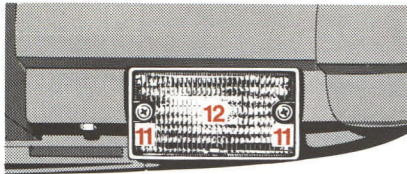

8458

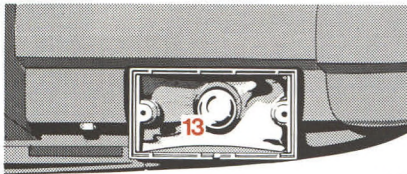

8459

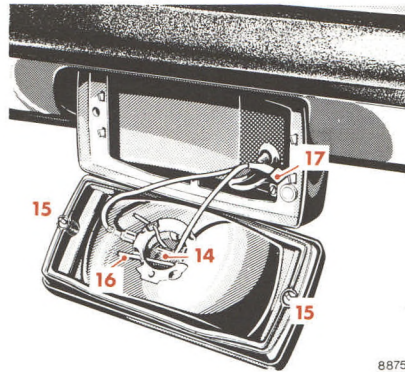

8875

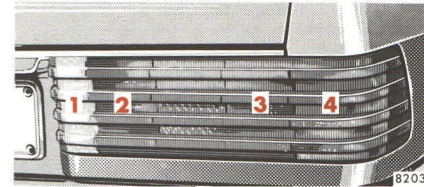

8203

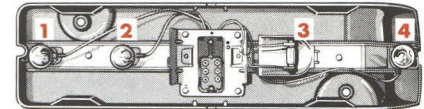

8204

- 13 Bulb for turn signal, clearance and standing lamps 21/5 W/32/3 cp:

The lamps are located below the bumper.

Loosen securing screws (11) and remove lens (12).

Depress bulb (13), turn left and pull out. When replacing the lens, it must be ensured that the lug in the lens is at the bottom.

- 14 Bulb for fog lamp (H3):  
Loosen securing screws (15) and remove housing. Detach holding spring (16), remove bulb (14) and disconnect plug (17).

### Tail Lamp Assembly

Remove both knurled nuts in the trunk and pull off lens assembly. To replace the bulbs, depress, turn left and pull out.

- 1 Backup lamp (21 W/32 cp)
- 2 Stop lamp (21 W/32 cp)
- 3 Tail, parking and standing lamp (10 W festoon lamp)
- 4 Turn signal lamp (21 W/32 cp) side marker lamp (5 W festoon lamp)

## Electrical System

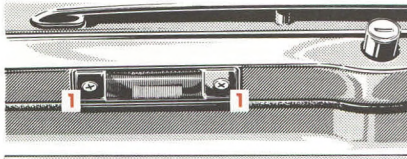

8212

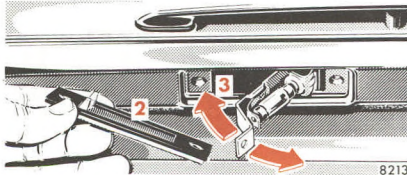

8213

### License Plate Lamps (5 W festoon lamp)

Loosen both the securing screws (1) of the lamp, detach lens with gasket (2) and pull down lamp holder (3) on the L-H side. When replacing the lens, it must be assured that the lug in the lens is on the L-H side.

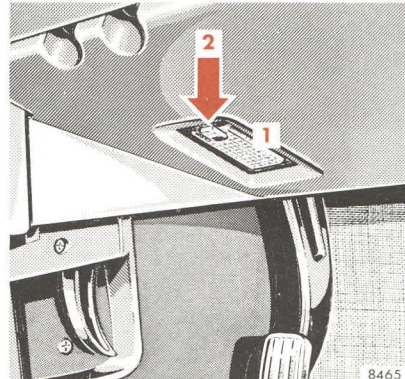

8465

### Footwell Lamps (10 W festoon lamp)

Press off lamp (1) at the nose (2), replace bulb and press lamp on again.

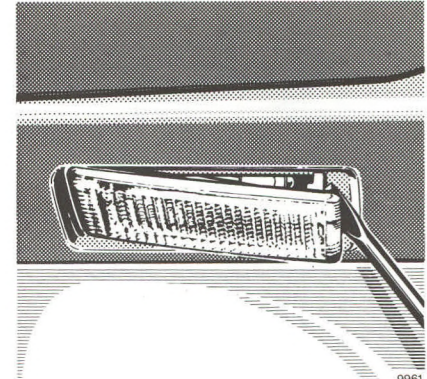

9961

### Dome Lamps (5 W festoon lamp)

To replace the bulb, carefully pry loose the dome lamp lens by inserting a small screwdriver blade into the slot at one of the lens edges and pulling out the lens.

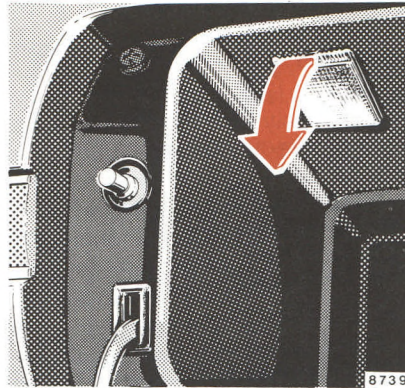

**Glove Compartment Lamp**  
(5 W festoon lamp)

To replace the bulb, pull out lamp.

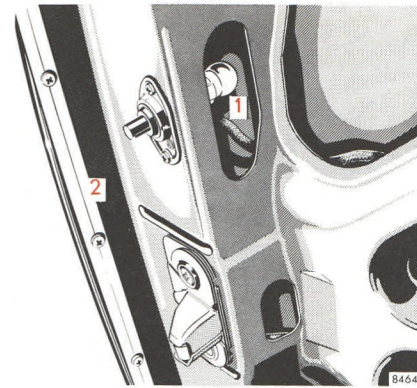

**Trunk Lamp** (5 W/3 cp)

The trunk lamp (1) is easily accessible when the trunk lid (2) is opened. To replace the bulb, depress, turn counterclockwise and take it out.

## Electrical System

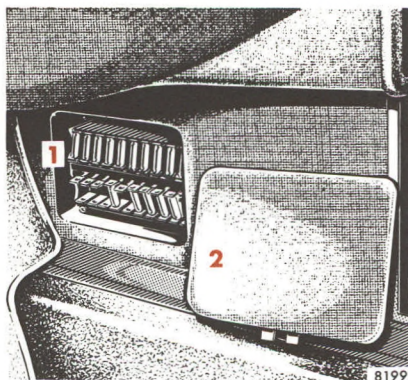

### Fuses

The fuse box (1) is accommodated in the R-H side floor space.

A table in the fuse box cover (2) depicts all the protected electrical units.

Fuses must not be repaired or bridged.

Spare fuses for emergencies (observe amperage and color) are stored with the tools.

Diagnose the cause of a short circuit before replacing a burned-out fuse.

### Battery

The battery is located in the trunk.

Check fluid level in each cell approximately every four weeks, and more frequently during the summer and in hot climates.

Refill battery only with distilled water. Do not use metal funnels nor push through the overfill-protection diaphragms in filler holes.

The battery is completely filled when the water stops draining through the overfill-protection diaphragm.

To check the battery charge with a hydrometer, push its tip through the overfill-protection diaphragm and take the electrolyte sample.

Coat battery terminal clamps with acidproof grease. Keep battery clean and dry.

Only tow vehicle with the battery connected.

Only charge battery with a battery charger when it is disconnected from the vehicle electrical circuit.

Caution:

While the engine is running the battery terminal clamps must not be loosened or detached as otherwise the alternator and other electronic units would be damaged.

### Spark Plugs

This vehicle is equipped with spark plugs as required for driving in the USA. Should additional information be necessary, your MERCEDES-BENZ dealer will be happy to offer advice.

Towing eyes are situated underneath the R-H front and rear end. Use a solid towing link such as a towbar.

Only tow-start vehicle with the battery connected and the key in steering lock position "2".

### Warning:

When the engine is not running, both the service brake and the steering are without power assistance. Under these circumstances, a much greater effort is necessary to steer or stop the vehicle.

### Emergency Engine Start (Tow-starting)

The engine must be cold if it is to be started by towing or pushing the vehicle.

Never start a hot engine by towing or pushing the vehicle as the catalysts might otherwise suffer damage.

Move selector lever to position "N". Turn key in steering lock to position "2" and have vehicle towed.

To start the engine, move selector lever to "2". Only touch the accelerator when the engine is turning. As soon as the engine has started, quickly return selector lever to "N".

If the engine fails to fire within a few seconds, return the selector lever from "2" to "N" as otherwise the transmission may be damaged.

For another starting attempt, tow car again for a short while with the selector lever in position "N" and then repeat starting procedure.

The same procedure may be used for starting the engine while rolling downhill.

### Towing the Vehicle

The vehicle may be towed with all of the wheels on the ground and the selector lever in position "N" for distances up to 120 km/75 miles and at a speed not to exceed 50 km/h/30 mph.

To positively avoid a possibility of damage to the transmission, however, we recommend to disconnect the drive shaft at the rear axle drive flange on any towing beyond a short tow to a nearby garage.

Towing by lifting the front wheels is not recommended, since damage to the underside of the vehicle may occur.

Towing on a "dolly" with the rear wheels lifted is preferred. Attach T-hooks to the tie-down slots. Position a 4 ft long, 4 in x 4 in piece of wood under the bumper, behind the exhaust pipe. Position the towbar at the lower edge of the bumper.

## Jump Starting

If the battery is discharged the engine can be started with jumper cables (minimum cable cross section is 35 mm<sup>2</sup>) and the (12 V) battery of another vehicle. Proceed as follows:

1. Turn key to steering lock position "0".
2. First connect jumper cables to the positive battery terminals and then to the negative terminals.
3. Start and run engine of jumper vehicle at high idle.
4. Start engine of the disabled vehicle in the usual manner.
5. After the engine has started, first remove jumper cables from the negative battery terminals and then from the positive terminals.

### Instructions:

A discharged battery can freeze at approx.  $-10^{\circ}\text{C}$  /  $+14^{\circ}\text{F}$ . In all cases it must be thawed out before jumper cables are used.

Never lean over batteries while jump starting, you might get burned.

### Warning

Battery fluid contains sulfuric acid. Do not allow this fluid to come in contact with eyes, skin, or clothing. In case it does, immediately flush affected area with water.

A battery will also produce hydrogen gas, which is flammable and explosive. Keep flames or sparks away from battery, i.e. improper connection of jumper cables, cigarette smoking, etc.

## Unlocking of the Filler Flap

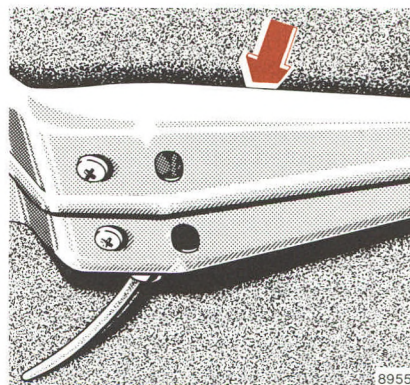

If the central locking system does not release the fuel filler flap automatically, pull down right trunk panel slightly and pull back the connecting rod between the vacuum element and door tab.



Technical Data  
Fuels Coolants  
Lubricants etc.



## Identification Plates

When ordering spare parts, please quote chassis and engine numbers.

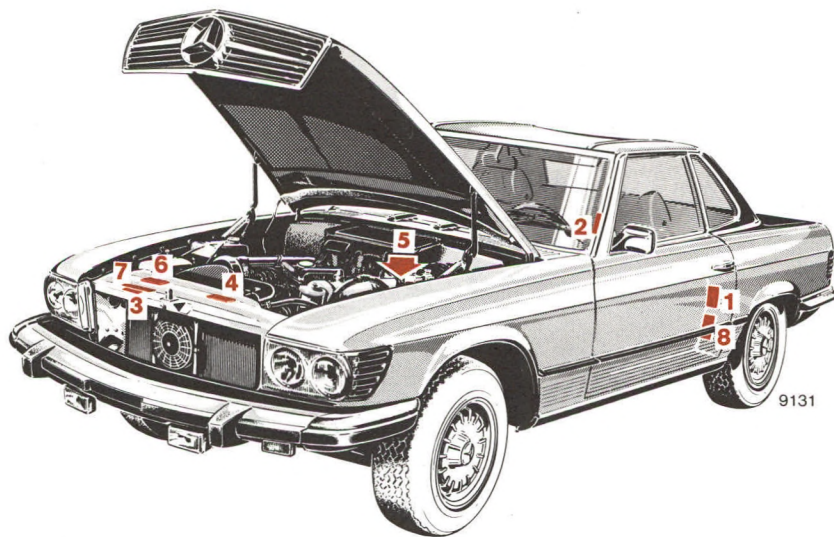

1 Certification Tag (left door pillar)  
2 Identification Tag (left window post)

3 Chassis No.  
4 Body No. and Paintwork No.  
5 Engine No.

6 Information Tag  
California version  
Vacuum line routing for  
emission control system  
7 Emission Control Tag  
8 Emission Control Tag  
Catalyst Information

## Vehicle Data Cards

---

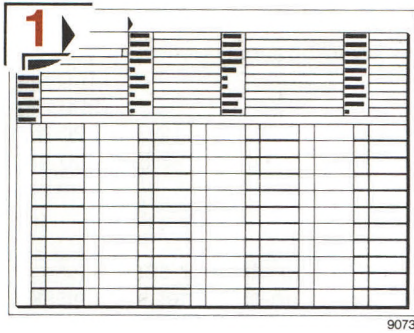

The vehicle data cards bear all the important data relating to your vehicle.

Data card No. 1 bears the key number and should never be left in the vehicle. Submit this card to your MERCEDES-BENZ service station to request a replacement key in case of loss.

Data card No. 2 bears no key data and is kept in the Maintenance Booklet. Presenting this card to the service station will facilitate the processing of the order.

## Warranty Coverage

---

Your car is covered under the terms of the “warranties” printed in the Owner’s Service and Warranty Policy Booklet and your dealer will exchange or repair any defective parts in accordance with the terms of the following warranties:

1. New vehicle limited warranty
2. Emission systems warranty
3. Emission performance warranty
4. California emission control systems warranty (state of California only unless purchased optionally for diesel models)

### Loss of Owner’s Service and Warranty Policy

Should you lose your Owner’s Service and Warranty Policy Booklet, have your local MB dealer arrange for a replacement. It will be mailed to you.

## Technical Data

---

Chassis..... 380 SL (107 045)

### Engine

Engine ..... 116  
Mode of operation ..... 4-stroke engine,  
gasoline injection  
No. of cylinders ..... 8  
Bore ..... 88.0 mm/3.46 in  
Stroke ..... 78.9 mm/3.10 in  
Total piston displacement ..... 3839 cm<sup>3</sup>/234.3 in<sup>3</sup>  
Compression ratio ..... 8.3  
Output according to SAE ..... 116 kW/4750 rpm/  
155 net-bhp/4750 rpm  
Firing order ..... 1-5-4-8-6-3-7-2

### V-belts:

Water pump – fan – power steering pump  
2 V-belts ..... 9.5 x 1100 mm  
Alternator ..... 9.5 x 990 mm  
Air conditioning ..... 12.5 x 920 mm  
Air pump ..... 9.5 x 750 mm

### Transmission

Design ..... Automatic four-speed  
torque-converter transmission

### Steering System

Design ..... Power steering

### Electrical System

Alternator ..... 14 V/70 A  
Starter motor ..... 12 V/1.5 kW  
Battery ..... 12 V/88 Ah  
Spark plugs ..... see "last page"

**Rims – Tires**

Rims (forged light alloy rims) ..... 6½ J × 14 H 2  
Summer tires:  
Radial-ply tires..... 205/70 R 14 93 H  
Winter tires:  
Radial-ply tires..... 205/70 R 14 93 Q M+S  
205/70 R 14 93 T M+S

**Weights** ..... See certification tag

**Main Dimensions**

Overall vehicle length ..... 4580 mm/180.3 in  
Overall vehicle width ..... 1790 mm/ 70.5 in  
Overall height,  
Roadster ..... 1300 mm/ 51.2 in  
Hardtop ..... 1290 mm/ 50.8 in  
Wheel base ..... 2460 mm/ 96.9 in  
Track, front ..... 1452 mm/ 57.2 in  
Track, rear ..... 1440 mm/ 56.7 in

**Fuels Coolants Lubricants etc. Capacities**

Vehicle components and their respective lubricants must match.

Therefore use only brands tested and recommended by us.

Enquire at your MERCEDES-BENZ service station.

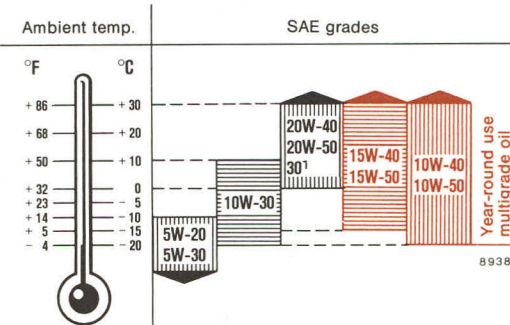
	Capacity	Fuels, coolants, lubricants, etc.
<p>Total oil capacity in case of engine oil and filter change</p>	<p>8.0 l/8.5 US qt</p>	<p><b>Recommended engine oil</b></p>  <p>Ambient temp.                      SAE grades</p> <p>°F                      °C</p> <p>+ 86                      + 30</p> <p>+ 68                      + 20</p> <p>+ 50                      + 10</p> <p>+ 32                      0</p> <p>+ 23                      - 5</p> <p>+ 14                      - 10</p> <p>+ 5                      - 15</p> <p>- 4                      - 20</p> <p>5W-20                      5W-30</p> <p>10W-30</p> <p>20W-40                      20W-50                      30W-1</p> <p>15W-40                      15W-50</p> <p>10W-40                      10W-50</p> <p>Year-round use multigrade oil</p> <p>8938</p> <p><sup>1</sup> SAE 40 may be used if ambient temperatures constantly exceed + 30° C/+ 86° F.</p>
<p>Automatic transmission</p>	<p>Initial fill: 8.6 l/9.1 US qt Fluid change: 7.7 l/8.1 US qt</p>	<p>Automatic transmission fluid for automatic transmission<sup>2</sup></p> <p><sup>2</sup> Any MERCEDES-BENZ service station will advise you on recommended brands.</p>

## Fuels Coolants Lubricants etc. Capacities

	Capacity	Fuels, coolants, lubricants, etc.
Rear axle	1.3 l/1.4 US qt	Hypoid gear oil SAE 90, 85 W 90 <sup>1</sup>
Accelerator control linkage		Hydraulic fluid
Power steering	1.4 l/1.5 US qt	Automatic transmission fluid for power steering <sup>1</sup>
Front wheel hubs	approx. 70 g each/2.5 oz. each	High temperature roller bearing grease
Grease nipples		Multipurpose or lubrication grease
Door locks		Powdered graphite
Battery terminals		Bosch special grease
Brake reservoir	approximately 0.5 l/0.5 US qt	Brake fluid <sup>1</sup>
Windshield washer system	approximately 5.0 l/5.3 US qt	Windshield washer solvent
Fuel tank including a reserve of	approximately 85 l/22.5 US gal approximately 11.5 l/3.0 US gal	Unleaded gasoline: Average Octane of Research and Motor 87 (RON of 91)
Cooling system	12.5 l/13.2 US qt	Coolant <sup>1</sup>

<sup>1</sup> Any MERCEDES-BENZ service station will advise you on recommended brands.

### **Engine Oils**

Engine oils are specifically tested for their suitability in our engines. Therefore, use only engine oils recommended by us. Information on recommended brands is available at any MERCEDES-BENZ service station.

On a new vehicle, the engine is filled with an initial operation oil in

the factory. This oil is specially developed for the specific operating conditions during the first 1300–1600 km/800–1000 miles.

A recommended engine oil may be used for topping up if the oil level drops to the dipstick minimum mark prior to the first service 1300–1600 km/800–1000 miles.

### **Brake Fluid**

During the course of the operation of the vehicle, the boiling point of the brake fluid is continuously being reduced through the absorption of moisture from the atmosphere.

Under extremely hard operating conditions, this moisture content can lead to the formation of vapor in the system thus reducing the system's efficiency. The brake fluid must therefore be replaced annually, preferably in the spring. It is recommended to use only brake fluid approved by MERCEDES-BENZ.

Your MERCEDES-BENZ dealer will provide you with additional information.



### Coolants

The coolant is a mixture of water and anti-corrosion/antifreeze. In production, the cooling system is filled with an anti-corrosion/antifreeze-water mixture offering protection to approx.  $-30^{\circ}\text{C}/-22^{\circ}\text{F}$ . The red mark on the temperature gauge in the instrument cluster is matched to this anti-corrosion/antifreeze-water mixture (approx. boiling point  $125^{\circ}\text{C}/257^{\circ}\text{F}$ ). The protection against corrosion is also ensured by this mixture making it unnecessary to add a corrosion inhibitor.

The coolant remains in the cooling system all year long and must be renewed after 3 years at the latest.

If coolant is lost, replace missing quantity with water (potable water quality) plus anti-corrosion/antifreeze of a recommended brand.

For reasons of corrosion inhibition the minimum proportion of anti-corrosion/antifreeze must be 34%, which gives anti-corrosion/antifreeze protection down to  $-20^{\circ}\text{C}/-4^{\circ}\text{F}$ .

If anti-corrosion/antifreeze is temporarily not available, add a corrosion inhibitor to the cooling water to ensure proper protection against corrosion. To treat the cooling water, do not use more than 1% ( $10\text{ cm}^3/\text{l}$ ) of a recommended corrosion inhibitor.

Without anti-corrosion/antifreeze in the cooling system, the water already starts boiling at approx.  $118^{\circ}\text{C}/224^{\circ}\text{F}$ , which means that the pointer of the temperature gauge in the instrument cluster may still be below the red mark.

Driving the vehicle without anti-corrosion/antifreeze should be done only in emergency situations. Add anti-corrosion/antifreeze as soon as possible.

### Anti-corrosion/Antifreeze

Your vehicle contains a number of aluminium parts. The use of aluminium components in motor vehicle engines necessitates that anti-corrosion/antifreeze/coolant used in such engines be specifically formulated to protect the aluminium parts. (Failure to use such anti-corrosion/antifreeze/coolant may

result in a significantly shortened service life.)

While there may be a number of anti-corrosion/antifreeze/coolants available which will provide the required protection, all such products have not been tested for MERCEDES-BENZ vehicles. The following product, however, is recommended for use in your car: MERCEDES-BENZ Anti-Freeze and Summer Coolant.

Prior to the onset of the cold season, check the coolant for its resistance to cold. Repeat this check during the cold spell. Regular testing of the anti-corrosion/antifreeze concentration is carried out only at each MERCEDES-BENZ maintenance service.

Protects up to	Anti-corrosion/antifreeze
$-20^{\circ}\text{C}$ $-4^{\circ}\text{F}$	4.50 l/4.8 US qt
$-30^{\circ}\text{C}$ $-22^{\circ}\text{F}$	5.50 l/5.8 US qt
$-40^{\circ}\text{C}$ $-40^{\circ}\text{F}$	6.50 l/6.9 US qt

## Service Literature

---

Customers who are interested in ordering service literature for their vehicles are advised to contact our subsidiaries in the U.S. or Canada at the following addresses.

for U.S.A.: Mercedes-Benz of N.A. Inc.  
One Mercedes Drive  
P. O. Box 350  
Montvale, New Jersey 07645  
Att: Technical Publications  
Tel: (201) 573-0600

for Canada: Mercedes-Benz of Canada  
849 Eglinton Ave., East  
Toronto 17, Ont., Canada  
Att: Service Department  
Tel: 416-425-3550

The above companies will be happy to handle any such requests from customers.

We consider this to be the best way to obtain accurate information for your vehicle.

This has been prepared as required of all manufacturers of passenger cars under Title 49, Code of U.S. Federal Regulations, Part 575 pursuant to the "National Traffic and Motor Vehicle Safety Act of 1966".

### **Uniform Tire Quality Grading**

Relevant tire grade information on tire flanks.

All passenger car tires must conform to federal safety requirements in addition to these grades.

Traction "A", "B", "C"

The traction grades, from highest to lowest, are "A", "B" and "C" and they represent the tire's ability to stop on wet pavement as measured under controlled conditions on specified government test surfaces of asphalt and concrete. A tire marked "C" may have poor traction performance. Warning: The traction grade assigned to this tire is based on braking (straightahead) traction tests and does not include cornering (turning) traction.

Temperature "A", "B", "C"

The temperature grades of "A" (the highest), "B" and "C" representing the tire's resistance to the generation of heat and its ability to dissipate heat when tested under controlled conditions on a specified indoor laboratory test wheel. Sustained high temperature can cause the material of the tire to degenerate and reduce tire life, and excessive temperature can lead to sudden tire failure. The grade "C" corresponds to a level of performance which all passenger car tires must meet under the Federal Motor Vehicle Safety Standard No. 109. Grades "B" and "A" represent higher levels of performance on the laboratory test wheel than the minimum required by law. Warning: The temperature grade for this tire is established for a tire that is properly inflated and not overloaded. Excessive speed, underinflation, or excessive loading, either separately or in combination, can cause heat buildup and possible tire failure.

## Consumer Information

### Vehicle Stopping Distance

This figure indicates braking performance that can be met or exceeded by the vehicles to which it applies, under different conditions of loading and with partial failures of the braking system. The information presented represents results obtainable by skilled drivers under controlled road and vehicle conditions, and the information may not be correct under other conditions.

Description of the vehicles to which this table applies: **380 SL**

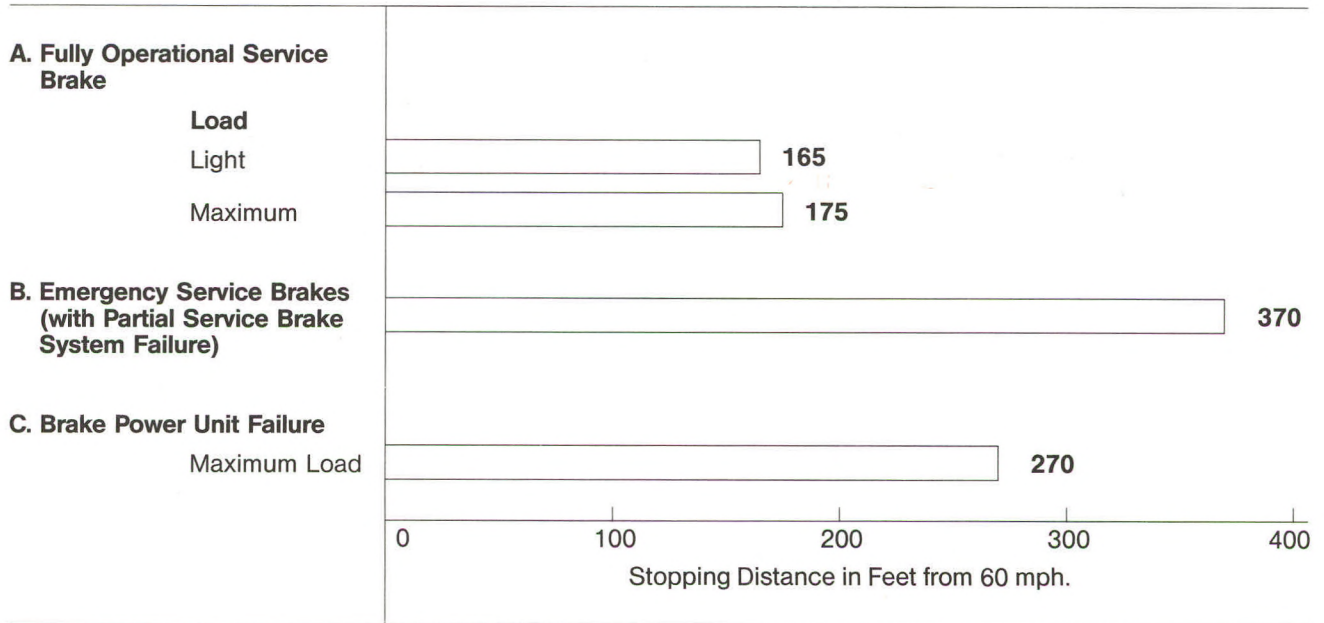



**Printed in Germany**

We reserve the right to modify the technical details of the vehicle as given in the data and illustrations of this Owner's Manual (s.e.e.o.). Reprinting, translation and copying, even of excerpts, is not permitted without our prior authorization in writing.

ZKD/8.83.8/Ru.

Daimler-Benz AG  
Stuttgart-Untertuerkheim  
Zentralkundendienst



Mercedes-Benz  
**service**

107 584 05 97  
USA-Ausgabe C 1984  
Order No. 6550 5483 13

## What You Should Know at the Gas Station

- **Fuel:** Unleaded gasoline: Average Octane of Research and Motor 87 (RON of 91).

Fuel tank capacity approx. 85 l/22.5 US gal, this includes approx. 11.5 l/3.0 US gal reserve.

Only fill fuel tank until the filler nozzle unit cuts out – do not overfill.

- **Engine Oil:** Engine oil level check see page 61.

Quantity differential between upper and lower dipstick marking level 2.0 l/2.1 US qt.

Year-round multigrade oils 10 W-40, 10 W-50, 15 W-40, 15 W-50.

For further information, refer to page 76.

- **Automatic Transmission:** Automatic transmission fluid for automatic transmission.

For level checks and replenishment, refer to page 63.

- **Tire Pressure:** Cold tires:

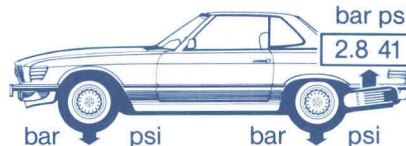

Summer tires:
Winter tires:

2.2 <sup>1</sup>	32 <sup>1</sup>
2.3	33

2.5 <sup>1</sup>	36 <sup>1</sup>
2.6	38

- **Coolant:** For normal replenishment, use water (potable water quality).

For further information (e.g. anti-corrosion/antifreeze), refer to page 79.

- **Bulbs:** High and low beams: Sealed beam/Halogen insert No. 1 and 2, turn signal, clearance and standing lamps, front 21/5 W/32/3 cp, turn signal lamps, rear 21 W/32 cp, tail and standing lamps, rear 10 W festoon lamp, stop lamps 21 W/32 cp, license plate lamps 5 W festoon lamp.

- **Spark Plugs:** Beru 14 – 9 D, Beru 14 – 9 DU, Bosch W 9 D, Bosch W 9 DC, Champion N 12 Y, Champion N 12 YC.

Warm tires:  
Pressure may rise by up to +0.5 bar/+7 psi.

Never release any air from a warm tire to off-set pressure increase!

<sup>1</sup> For driving above 180 km/h/110 mph +0.2 bar/+3 psi.

For driving up to 160 km/h/100 mph –0.2 bar/–3 psi.



