

Owner's Manual

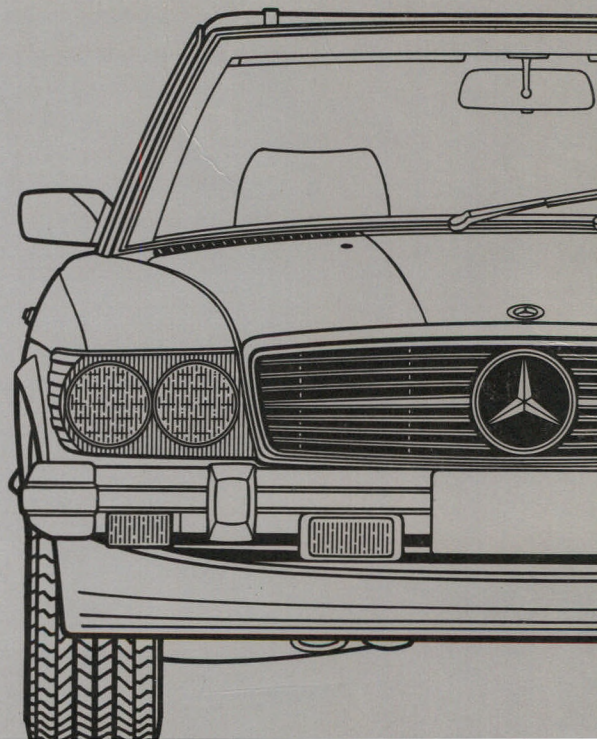

560 SL

1987



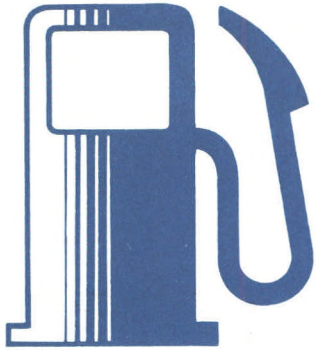

\$ 20

What You Should Know at the Gas Station

See last page

Drive Sensibly – Save Fuel

Fuel consumption, to a great extent, depends on driving habits and operating conditions.

To save fuel you should:

- keep tires at the recommended inflation pressures
- remove unnecessary loads
- remove ski racks or roof-mounted luggage racks when not in use
- allow engine to warm up under low load use
- avoid frequent acceleration and deceleration
- have all maintenance work performed at regular intervals by an authorized MERCEDES-BENZ dealer.

Fuel consumption is also increased by driving in cold weather, in stop-and-go traffic, on short trips and in hilly country.

Owner's Manual



560 SL

Model 107

1987

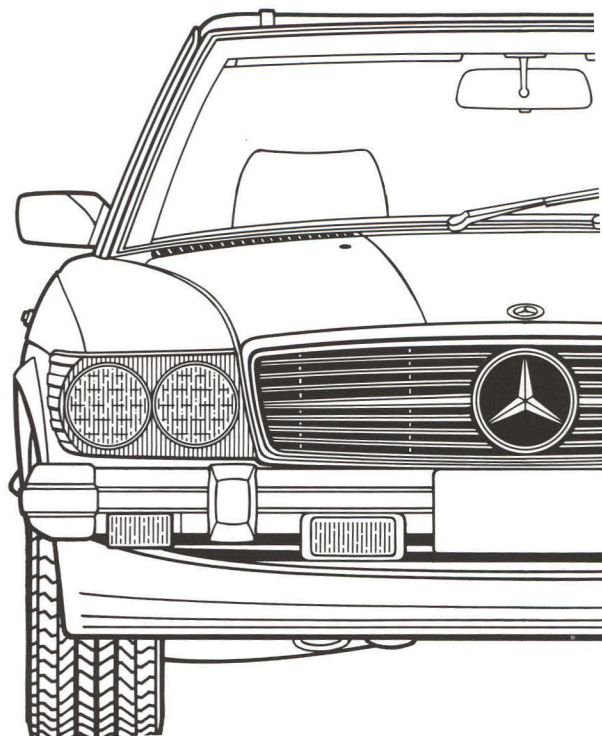

Printed in Germany

We reserve the right to modify the technical details of the vehicle as given in the data and illustrations of this Owner's Manual (s.e.e.o.). Reprinting, translation and copying, even of excerpts, is not permitted without our prior authorization in writing.

ZKD/2.87.8/Rung

Our company and staff congratulate you on the purchase of your new MERCEDES-BENZ.

Your selection of our product is a demonstration of your trust in our company name. Further, it exemplifies your desire to own an automobile that will be as easy as possible to operate and provide years of service.

Your MERCEDES-BENZ represents the efforts of many skilled engineers and craftsmen. To ensure your pleasure of ownership, we ask you to make a small investment of your time:

- Please read this manual carefully before putting it aside.
- Please consider the recommendations contained in this manual. They are designed to acquaint you with the operation of your MERCEDES-BENZ.

We extend our best wishes for many miles of safe, pleasurable driving.

Daimler-Benz Aktiengesellschaft

Introduction

This Owner's Manual contains a great deal of useful information. We urge you to read it carefully and familiarize yourself with the vehicle before driving.

For your own safety and longer service life of the vehicle, we urge you to follow the instructions and warnings. Ignoring them could result in damage to the vehicle or personal injury.

Your vehicle may have some or all of the equipment described. Therefore, you may find explanations of equipment not installed in your vehicle. If you have any questions about the operation of any equipment, your authorized MERCEDES-BENZ dealer will be glad to demonstrate the proper procedures.

Owner's Service and Warranty Policy

The Owner's Service and Warranty Policy Booklet contains detailed information about the warranties covering your MERCEDES-BENZ, including:

- New Car Limited Warranty
- Emissions Systems Warranty
- Emission Performance Warranty
- California Emission Control System Warranty (California Only)

Maintenance

The Maintenance Booklet describes all the necessary maintenance work which should be performed at regular intervals.

Always have the Maintenance Booklet with you when you take the vehicle to your authorized MERCEDES-BENZ dealer for service. The Service Advisor will record each service.

Roadside Assistance

Although your Mercedes-Benz is built to be as troublefree as possible, a Roadside Assistance Program is available to provide emergency roadside service after normal dealer hours and on weekends and holidays in the contiguous United States.

Roadside Assistance is available Monday through Friday from 5:00 PM to 12:00 Midnight and on Saturday, Sunday and legal holidays from 8:00 AM to 12:00 Midnight. In the event of a breakdown during these hours, telephone this toll-free number:

1-800-222-0100.

For additional information, refer to the Mercedes-Benz Roadside Assistance Program Booklet in your glove compartment.

Change of Address or Ownership

If you change your address, be sure to send in the "Change of Address Notice" found in the Owner's Service and Warranty Policy Booklet. It is in your own interest that we can contact you should the need arise.

If you sell your Mercedes, please leave all owner's literature with the vehicle to make it available to the next owner.

If you bought this vehicle used, be sure to send in the "Notice of Purchase of Used Car" found in the Owner's Service and Warranty Policy Booklet.

Operating Your Vehicle Outside the U.S.A. or Canada

If you plan to operate your vehicle in foreign countries, please be aware that:

- unleaded fuels for vehicles with catalytic converters may not be available; the use of leaded fuels will damage the catalyysts,
- fuel may have a considerably lower octane rating, and improper fuel can cause engine damage,
- service facilities or replacement parts may not be readily available.

Certain Mercedes-Benz models are available for delivery in Europe under our European Delivery Program. For details, consult your authorized MERCEDES-BENZ dealer or write to:

Mercedes-Benz of North America, Inc.
European Delivery Department
One Mercedes Drive
Montvale, NJ 07645

Optional equipment is also described in this manual, including operating instructions wherever necessary. Since they are special-order items, the descriptions and illustrations herein may vary slightly from the actual equipment of your vehicle.

If there are any equipment details that are not shown or described in this Owner's Manual, your authorized MERCEDES-BENZ dealer will be glad to inform you of correct care and operating procedures.

The Owner's Manual and Maintenance Booklet are important documents and should be kept with the vehicle.

**Instruments and Controls, Starting the Engine
Driving Instructions, Service and Maintenance**

Operation

Driving

Practical Hints

**Technical Data
Fuels, Coolants, Lubricants, etc.
Consumer Information**

Index

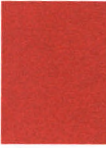

Check Regularly and Before a Long Trip

See page 108

The First 1500 km (1000 Miles)

The more cautiously you treat your vehicle during the break-in period, the more satisfied you will be with its performance later on. Therefore, drive your vehicle during the first 1500 km (1000 miles) at moderate vehicle and engine speeds.

During this period, avoid heavy loads (full throttle driving) and high RPMs (no more than $\frac{2}{3}$ of maximum permissible speed in each gear).

Avoid accelerating by kickdown. It is not recommended to brake the vehicle by manually shifting to a lower gear. We recommend to select positions "3" or "2" only at moderate speeds (for hill driving).

After 1500 km (1000 miles) speeds may gradually be increased to the permissible maximum.

Instruments and Controls, Starting the Engine Driving Instructions, Service and Maintenance

Instruments and Controls	10
Instrument Cluster	12
Catalytic Converter Cautions	14
Starting and Turning off the Engine	15
Driving Instructions	16
MERCEDES-BENZ Maintenance System	19

Instruments and Controls

For more detailed descriptions see specified pages.

- 1** Adjustable air outlets (page 22)
- 2** Slide lever for adjustable air outlet (page 22)
- 3** Parking brake release knob (page 56)
- 4** Hood release handle (page 68)
- 5** Parking brake pedal (page 56)
- 6** Combination switch (page 40)
- 7** Exterior lamp switch (page 39)
- 8** Instruction tag (except tourist vehicle).
Use only premium unleaded gasoline
- 9** Cruise control (page 59)
- 10** Instrument cluster (page 12)
- 11** Horn control, air bag (page 35)
- 12** Steering lock with ignition/starter switch
(page 38)
- 13** Adjustable air outlets (page 22)
- 14** Outside temperature indicator (page 63)
- 15** Rear window defroster switch (page 43)
- 16** Automatic antenna switch (page 53)
- 17** Front dome lamps switch (page 44)
- 18** Radio (page 49)
- 19** Air recirculation switch (page 22)
- 20** Automatic climate control (page 22)
- 21** Ashtray with lighter (page 42, 88)
- 22** Left power window switch (page 44)
- 23** Left seat heater switch (page 32)
- 24** Hazard warning flasher system switch
- 25** Right seat heater switch (page 32)
- 26** Right power window switch (page 44)
- 27** Adjusting switch for exterior mirror on front
passenger side (page 41)
- 28** Glove compartment, illuminated (only with key in
steering lock positions 1 or 2)
To open, slide handle sideways
- 29** Loudspeaker cover, right and left

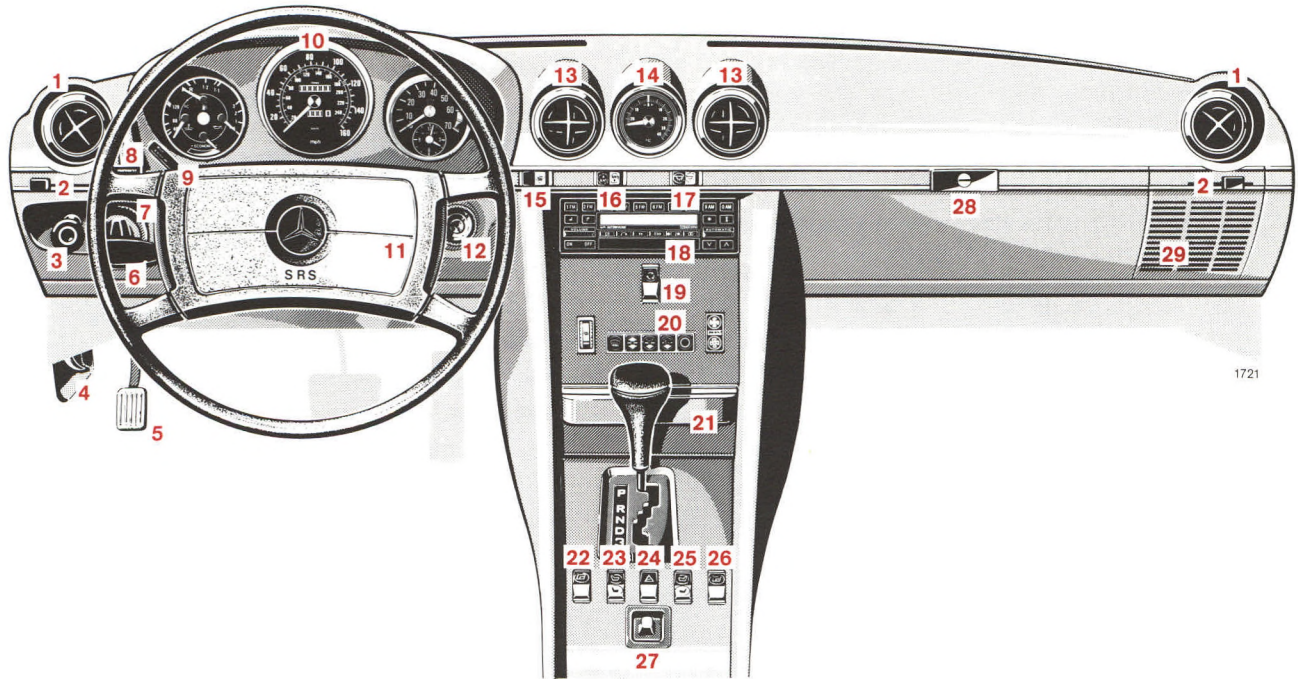

Instrument Cluster

- 1** Economical driving indicator (ECONOMY).
See page 64
- 2** Coolant temperature gauge
Up to red marking: Maximum permissible temperature for an anticorrosion/antifreeze-blended fill protecting down to -30°C (-22°F).
See page 62
- 3** Fuel gauge with reserve warning lamp (yellow).
See page 62
Fuel reserve and capacity, refer to page 97 and inside back cover
- 4** Oil pressure gauge (bar). See page 61
- 5** Main odometer
- 6** Trip odometer
- 7** Knob for clock adjustment
(press in for adjustments)
- 8** Electric clock
- 9** Tachometer
- 10** Red marking on tachometer:
Excessive engine speed
- 11** Turn signal indicator lamp, right (green)
- 12** Seat belt warning lamp (red)
- 13** O₂-Sensor malfunction indicator lamp (red):
If the indicator lamp comes on, it indicates a malfunction in the O₂-sensor circuit. The O₂-sensor circuit should be checked by an authorized MERCEDES-BENZ dealer at the first opportunity.
- 14** Supplemental restraint system (SRS) indicator lamp (red). See page 35
- 15** Antilock brake system (ABS) indicator lamp (yellow). See page 60
- 16** Dimmer knob for instrument lamps, continuous adjustment
- 17** Exterior light failure indicator lamp (yellow).
See page 62
- 18** Low windshield washer fluid level indicator lamp (yellow). See page 62
- 19** Low engine coolant level indicator lamp (yellow).
See page 62
- 20** Low engine oil level indicator lamp (yellow).
See page 61
- 21** Resetting knob for trip odometer
(push button)
- 22** Brake pad wear indicator lamp (yellow).
See page 61
- 23** Brake warning lamp (red). See pages 56, 61
- 24** Charge indicator lamp (red). See page 61
- 25** High beam indicator lamp (blue)
- 26** Turn signal indicator lamp, left (green)

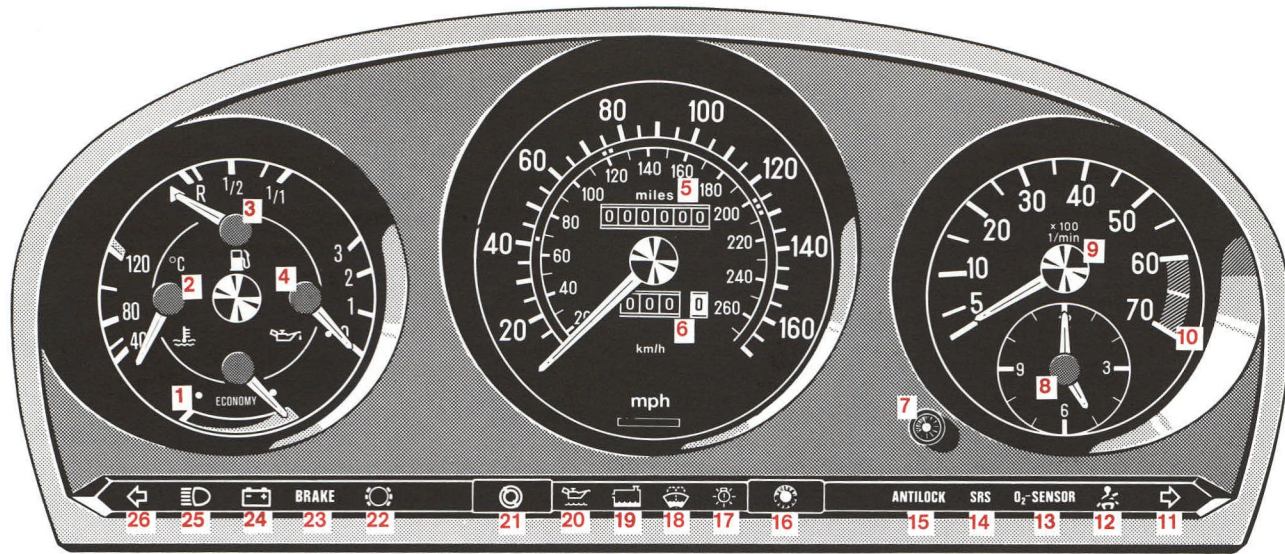

1405



Instrument Cluster

Catalytic Converter Cautions

Your MERCEDES-BENZ is equipped with monolithic catalytic converters, an important element in conjunction with the O₂-sensor to achieve substantial control of the pollutants in the exhaust emissions. Keep your vehicle in proper operating condition by following our recommended maintenance instructions as outlined in your maintenance booklet.

Caution!

To prevent damage to the catalytic converters, only use premium unleaded gasoline in this vehicle. Should any noticeable irregularities in the engine operation occur, excessive unburned fuel may reach the converter causing it to over-heat.

Warning!

As with any vehicle, do not idle, park or operate this vehicle in areas where combustible materials such as grass, hay or leaves can come into contact with the hot exhaust system, as these materials could be ignited.

Starting and Turning off the Engine

Engage parking brake and move the gear selector lever in either “P” or “N” position before starting the engine.

Turn key to steering lock position 2. The charge indicator lamp should come on.

Cold Engine

Turn key in steering lock clockwise to the stop. Do not depress accelerator. Release key only when the engine is firing regularly.

At ambient temperatures below -18°C (0°F), depress accelerator three times prior to starting.

Hot Engine

Turn key in steering lock clockwise to the stop. Do not depress accelerator. If the engine has not fired after approx. 4 seconds, depress accelerator and continue cranking until the engine is firing regularly. Release key and back off accelerator.

At very high coolant temperatures the engine starting time can be shortened if the accelerator is depressed slowly at the beginning of the starting process.

Turning off

Turn the key to steering lock position 0 and only remove the key when the vehicle is stopped.

If the coolant temperature is very high (e.g. after hard driving on mountain roads), do not shut off the engine immediately, allow it to run for 1–2 minutes at increased idle speed.

Important!

Due to the installed starter non-repeat unit, the key must be returned to steering lock position 0 before a new starting attempt is made.

Observe the oil pressure gauge immediately after starting the engine. In a very cold engine the oil pressure will only rise slowly, some time after the engine has started. Do not speed up the engine before pressure is registered on the pressure gauge.

The charge indicator lamp should go out as soon as the engine has started.

Should too much fuel have entered the engine due to several unsuccessful starting attempts and the engine will no longer fire, depress the accelerator while starting. This should make the mixture combustible again. Back off the accelerator only when the engine is firing regularly.

In areas where temperatures frequently drop below -25°C (-13°F), we recommend that a block heater be installed. Your authorized MERCEDES-BENZ dealer will advise you on this subject.

Driving Instructions

Power assistance

When the engine is not running, the brake and steering systems are without power assistance. Under these circumstances, a much greater effort is necessary to stop or steer the vehicle.

Brakes

Caution!

When driving down long and steep grades, relieve the brakes by shifting into "3", "2" or "B". This helps prevent overheating of the brakes and reduces brake pad wear. Do not exceed engine speed limits (see page 58).

After hard braking it is advisable to drive on for some time so the air stream will cool down the brakes faster.

Warning!

After driving in heavy rain for some time without applying the brakes or through water deep enough to wet brake components, the first braking action may be somewhat reduced and increased pedal pressure may be necessary. Be sure to maintain a safe distance from vehicles in front.

The condition of the parking brake system is checked each time the car is in the shop for maintenance.

Between maintenance checks it is a good practice to apply the parking brake once or twice while driving at approximately 50 km/h (30 mph) on a dry straight road. Apply brake lightly until a slight drag on the wheels is felt. Keep applying brake for about 10 seconds while pulling the release knob out before releasing the parking brake completely. This practice will keep the parking brake at maximum efficiency.

Warning!

The stop lamps will not come on when applying the parking brake only. Perform the procedure in the previous paragraph only when the road is clear of other traffic.

Caution!

Resting your foot on the brake pedal will cause excessive and premature wear of the brake pads.

All checks and maintenance work on the brake system should be carried out by an authorized MERCEDES-BENZ dealer.

If the parking brake is released and the brake warning lamp in the instrument cluster stays on, the brake fluid level in the reservoir is too low.

Brake pad wear or a leak in the system may be the reason for low brake fluid in the reservoir.

Have the brake system inspected at an authorized MERCEDES-BENZ dealer without delay.

Install only brake pads and brake fluid recommended by MERCEDES-BENZ.

If other than recommended brake pads are installed, the braking properties of the vehicle can be affected to an extent that the safety is substantially impaired.

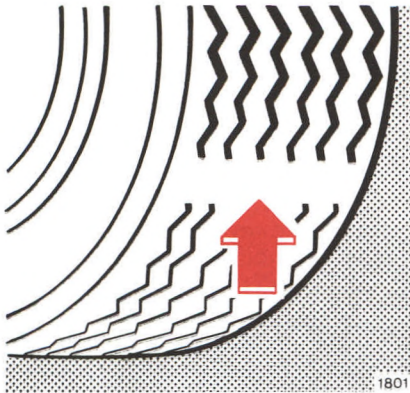

Tires

Tread wear indicators (TWI) are required by law. These indicators are located in six places on the tread circumference and become visible at a depth of approx. 2 mm ($\frac{1}{16}$ in), at which point the tire is considered worn and should be replaced.

The tread wear indicator appears as a solid band across the tread.

Warning!

Do not allow your tires to wear down too far. With less than 3 mm ($\frac{1}{8}$ in) of tread, the adhesion properties on a wet road are sharply reduced.

Depending upon the weather and/or road surface (conditions), the traction varies widely.

Specified tire pressure must be maintained. This applies particularly if the tires are subjected to high loads (e.g. high speeds, heavy loads, high ambient temperatures).

Aquaplaning

Depending on the depth of the water layer on the road, aquaplaning may occur, even at low speeds and with new tires. Avoid track grooves in the road and apply brakes cautiously in the rain.

Tire traction

The safe speed on a wet, snow covered or icy road is always lower than on a dry road.

You should pay particular attention to the condition of the road as soon as the prevailing temperatures fall close to the freezing point.

Warning!

If ice has formed on the road, tire traction will be substantially reduced. Under such weather conditions, drive, steer and brake with extreme caution.

We recommend M + S radial-ply tires for the winter season for all four wheels to insure normal balanced handling characteristics. On packed snow, they can reduce your stopping distance as compared with summer tires. Stopping distance, however, is still considerably greater than when the road is wet or dry.

Parking

Warning!

To reduce the risk of personal injury as a result of vehicle movement, before leaving the vehicle always:

- 1. Keep foot on brake pedal.**
- 2. Firmly depress parking brake pedal.**
- 3. Slowly release brake pedal.**
- 4. Move the selector lever to position "P".**
- 5. Turn front wheels towards the road curb.**
- 6. Turn the key to steering lock position 0 and remove.**

Note:

It is advisable to set the parking brake whenever leaving the vehicle. Also, when parking on hills, always apply the parking brake. In addition, move selector lever to position "P".

Winter Driving Instructions

The most important rule for slippery or icy roads is to drive sensibly and to avoid abrupt acceleration, braking and steering action. Do not use the cruise control system under such conditions.

When the vehicle is in danger of skidding, move selector lever to position "N". Try to keep the vehicle under control by corrective steering action.

Road salts and chemicals can adversely affect braking efficiency.

Increased pedal force may become necessary to produce the normal brake effect. We therefore recommend depressing the brake pedal repeatedly when traveling on salt-strewn roads at length. This can bring road salt impaired braking efficiency back to normal. A prerequisite is, however, that this is possible without endangering other drivers on the road.

If the vehicle is parked after being driven on salt treated roads, the braking efficiency should be tested as soon as possible after driving is resumed while observing the safety rules in the previous paragraph.

MERCEDES-BENZ Maintenance System

A maintenance booklet is included with your car, listing all the maintenance jobs that must be carried out after the following mileages:

Routine Maintenance

Inspection at
1300–1600 km (800–1000 miles)

Lubrication Service every
12 000 km (7500 miles)

Maintenance Service every
24 000 km (15 000 miles)

Additional Work every
48 000 km (30 000 miles)

For additional details refer to the Maintenance Booklet.

In the case of low mileage operation, the Maintenance Service must be carried out at least once every 2 years.

Engine Oil and Filter Change

Required every 12 000 km (7500 miles), or at least once a year (fall) when using year-round multigrade oil; otherwise at least twice a year (spring and fall).

For engine oil recommendations, see page 96.

Severe Operating Conditions

In the case of severe operating conditions or heavy use mainly in city traffic or over short distances, frequent mountain driving, poor roads, dusty and muddy conditions, hard and sporty driving etc., it may be necessary to carry out maintenance work at shorter than normal intervals, as follows:

Engine: Oil change with filter change every 6000 km (3750 miles)

Automatic transmission: Fluid change without filter change every 24 000 km (15 000 miles)

Tires: Inspect

Air filter: Clean or replace element.

Special Maintenance Measures

Brake fluid should be replaced annually, preferably in the spring.

It is recommended to use only brake fluid approved by MERCEDES-BENZ. Do not mix different types of brake fluids.

The coolant should be checked for sufficient protection before the start of and during the summer and winter seasons.

Have the coolant (water/anticorrosion/antifreeze mixture) replaced at least every three years (see “Fuels, Coolants, Lubricants, etc.”).

Maintenance Vouchers

Your authorized MERCEDES-BENZ dealer will certify in the maintenance booklet that all lubrication and maintenance services have been carried out at the correct intervals.

Operation

Automatic Climate Control	22
Car Keys	27
Opening the Doors	28
Locking and Unlocking of Doors	28
Central Locking System	29
Anti-Theft Alarm System	30
Seat Adjustment	31
Heated Seats	32
Supplemental Restraint System- Seat Belts, Emergency Tensioning Retractors, Driver Air Bag	33
Steering Lock	38
Exterior Lamp Switch	39
Combination Switch	40
Exterior Rear View Mirrors	41
Inside Rear View Mirror	41
Lighter	42
Sun Visors	42
Rear Window Defroster	43
Interior Lamps	44
Power Windows	44
Soft Top	45
Electronic Radio	49



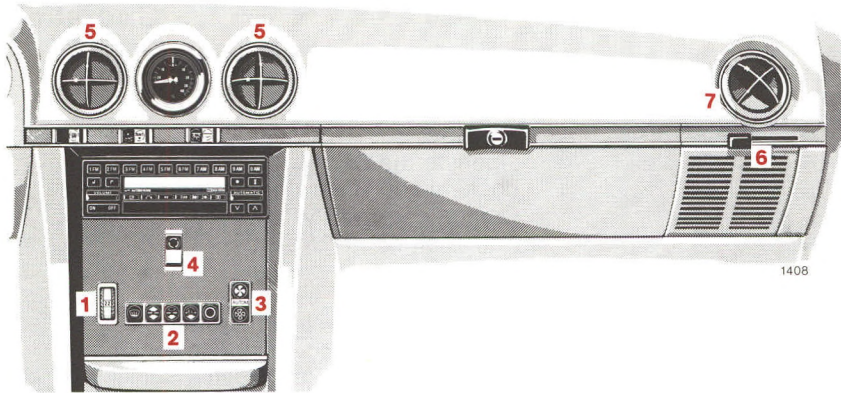



Automatic Climate Control

The engine must be running for the climate control system to operate.

1 Temperature selector

2 Pushbuttons for function selection (only press individually)

-  Defrost
-  Multi-Level
-  Normal setting
-  EC (Economy)
-  Off (air supply off)

3 Fan control buttons (only press individually)

 Maximum fan speed

 Automatic fan speed control

 Minimum fan speed

4 Air recirculation switch

5 Adjustable air outlets

6 Volume control levers for adjustable air outlets (7), right and left

7 Adjustable air outlets, right and left

For maximum operating efficiency, keep windows closed, the soft top raised or the hard top mounted.

Heating, cooling and air distribution within the vehicle's interior will be automatically controlled. This is accomplished with the temperature selector (1), the pushbuttons (2) and the fan control buttons (3).

The adjustable air outlets (5) and (7) can be moved to direct the flow of air as desired. Outlets (7) can be opened or closed with slide levers (6).

Slide lever (6) towards the center of the car to open outlet (7).

With the exterior lamps turned on (except standing lamps), the symbols on all buttons light up. Each button shines brighter when depressed.

Note:

The air conditioner removes considerable moisture from the air during operation. It is normal for water to drip on the ground through openings in the underbody.

Temperature Selection (° C)

The desired temperature can be adjusted by turning the temperature selector. The selected temperature is reached as quickly as possible and maintained. A basic setting of 22° C (72° F) is recommended. To avoid undesirable temperature fluctuations, a set temperature should be readjusted in small increments.

To override the automatic climate control turn the temperature wheel to either extreme end position “MIN” or “MAX”.

“MIN” (detent) = peak cooling performance.

The system operates with recirculated air, without additional fresh air.

“MAX” (detent) = maximum heating performance.

If button  is pressed with the temperature selector in the “MIN” or “MAX” position, the fan will run continuously at a high speed.

Air Recirculation

Pressing the symbol-side of the air recirculation switch causes air to be recirculated without additional fresh air and the red indicator lamp to light up. To turn the air recirculation switch off, press the blank side of the switch. The red indicator lamp should then go out.

The air recirculation mode can be used with high or low outside temperatures, or to prevent dust or annoying odors from entering the car’s interior. If the windows should fog up from the inside, the air recirculation switch should be turned off. The red indicator lamp should then go out.

Note:

The air recirculation mode will not come on if button  is pressed.

Function Setting

Off

In this setting, the Automatic Climate Control system is shut off including the fresh air supply to the interior of the car (to prevent entrance of odors, i.e. while driving through tunnels, etc. or to prevent the entrance of water from automatic car wash). Use this setting only temporarily while driving.

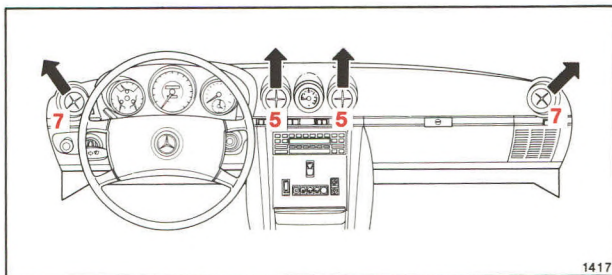

1417

 Economy setting – Ventilation

 Normal setting – Cooling

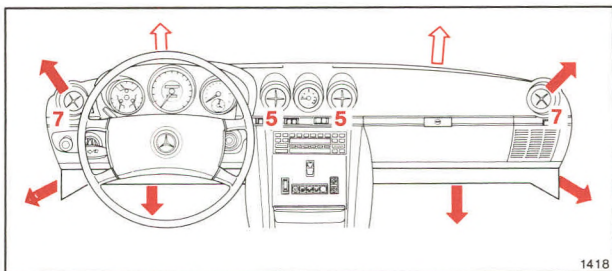

1418

 Economy setting – Heating

 Normal setting – Heating

 EC (ECONOMY) = Economical setting; the air conditioning compressor remains off.

In the remaining three settings, the air conditioning compressor comes on with ambient temperatures above +5° C (41° F).

As a fuel saving measure, we recommend this setting be used with cool outside temperatures, so that the air conditioning compressor remains off.



In the ventilation mode, air is emitted from outlets (5) and (7).

In the heating mode, warm air is primarily supplied to the foot area. In addition, warm air is also supplied to the ducts in the doors. Only enough warm air is supplied to the windshield and air outlets (7), to keep the glass defogged in normal weather conditions. In the heating mode, air may be emitted periodically from outlets (5), depending on the interior temperature.

With low outside temperatures, fan operation is cancelled until the engine coolant starts to warm up.

 Normal Setting

This setting is recommended when you wish to cool the interior of your car. It is also recommended for use in humid weather.

The setting  corresponds with setting  but, in addition, the air can also be cooled as necessary.

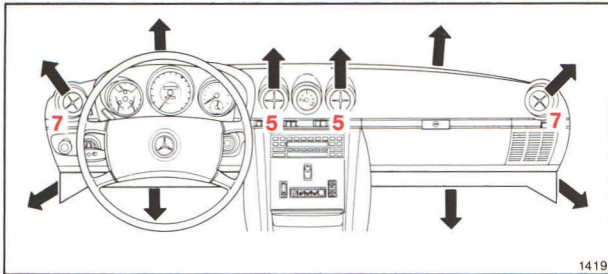

1419

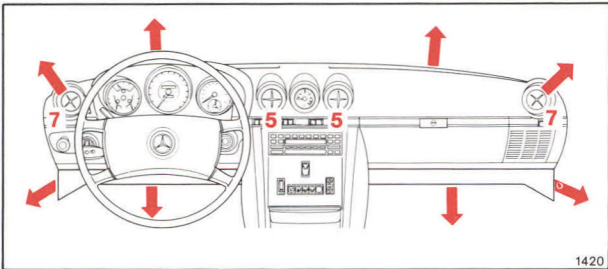

 Multi-Level ventilation – Cooling



1420

 Multi-Level ventilation – Heating

Multi-Level

This setting is used for clearing a fogged windshield. As soon as the windshield is clear, reset to  or .

In the heating mode, warm air is supplied to the windshield, foot area, air outlets (7), and to the ducts in the doors. Additionally, warm air may be emitted periodically from outlets (5), depending on the interior temperature.

In the cooling mode, cool air is supplied to the windshield, foot area, door ducts, and air outlets (5) and (7).

Note:

In warm, humid climates, prolonged use of this setting may create condensation on the outside of the windshield, directly above the defroster ducts.

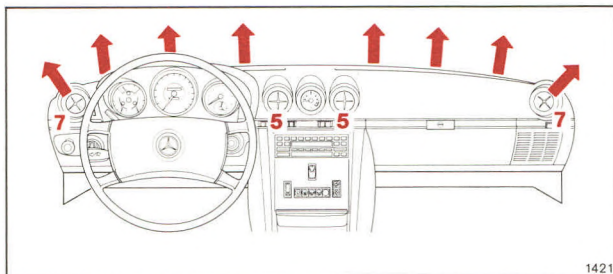

 Defrost

 Defrost

The maximum amount of heated air is directed to the windshield and side windows (outlets, 7). This setting overrides temperature and fan speed settings, and the air recirculation switch.

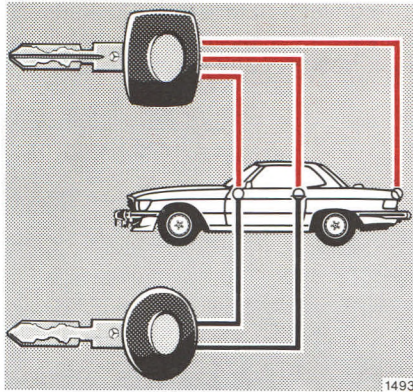

Car Keys

Included with your vehicle are two master keys, one valet key and one flat (master) key.

Master Key – square head with a red dot – fits all locks on the car. Arms/disarms the anti-theft alarm system.

Valet Key – round head – fits only the door locks and the steering lock. This key is intended to be used whenever the car is left with an attendant. Be sure to lock glove compartment and trunk with the master key. The valet key cannot be used to disarm the anti-theft alarm after the car was locked with the master key.

Flat Key



The flat key with a red dot fits all vehicle locks. Arms/disarms the anti-theft alarm system. We recommend that you carry the flat key with you and keep it in a safe place so that it is always handy. Never leave the flat key in the vehicle.

Obtaining Replacement Keys

Your vehicle is equipped with a theft deterrent locking system requiring a special key manufacturing process. For security reasons, replacement keys can only be obtained via your authorized MERCEDES-BENZ dealer.

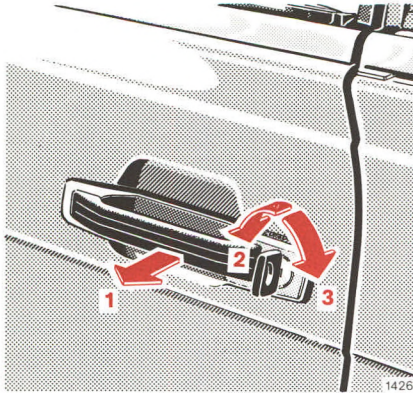

Opening the Doors

From outside: pull handle (1) outwards.

From inside: pull handle (4) in door panel.

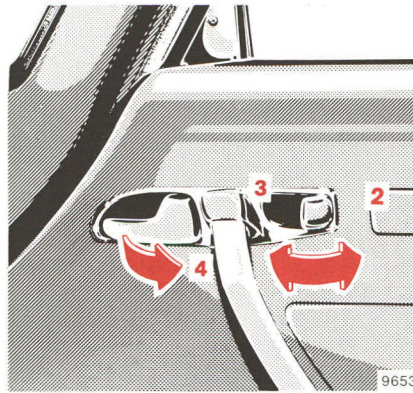

Locking and Unlocking of Doors

From the outside: turn key.

From the inside: actuate locking lever.

- 2 Unlocking
- 3 Locking

The driver's door can be locked only if it is closed and the door lock has properly engaged.

Central Locking System

The entire vehicle may be locked or unlocked with the central locking system:

- Using the master or valet key in either door.
- Using the master key in the trunk lock.

The central locking system locks or unlocks both doors, trunk lid and fuel filler flap simultaneously.

Doors

When you lock the car, both door locking levers will be in the forward position. If either one is in the rearward position the respective door is not properly closed. You should then, open and reclose this door (locking lever in the forward position).

Note:

The central locking system can be engaged from the driver- and passenger-side door locking lever, provided the driver's door is completely closed. It can also be engaged from the passenger-side if the ignition key is removed, or inserted in the steering lock without being turned (key in position 0).

If the car has been locked from the outside with the master key, the anti-theft alarm will come on if a door is opened from the inside, or if opened with the valet key.

Trunk

To unlock the trunk with the central locking system, turn the master key in the trunk lock completely to the left and let it return to the vertical position. Push in trunk lock button and open the trunk. To lock the trunk, turn the master key completely to the right and let it return to the vertical position.

The trunk can remain locked while the central locking system is unlocked (e.g. while driving or when leaving the car in a situation where it must be driven using the valet key, but you wish the trunk to remain locked at parking lots, workshops, etc.). Turn the master key completely to the right and pull it out in the horizontal position. Now the trunk can only be unlocked with the master key by turning it back completely to the left.

Important!

If the trunk is unlocked with the master key, the doors and fuel filler flap will also be unlocked. After closing the trunk, the central locking system must again be engaged using the key to relock the doors and fuel filler flap.

Note:

If the fuel filler flap cannot be opened, refer to "Unlocking of Fuel Filler Flap" (page 80).

Anti-Theft Alarm System

The anti-theft alarm can be armed or disarmed with the master key or flat key (identified by red dot) by locking or unlocking either door or the trunk.

Operation

Once the alarm system has been armed, the exterior vehicle lamps will flash and the horn will sound intermittently when someone tries to:

- open a door
- open the trunk
- open the hood
- remove the radio
- switch on or bridge the ignition circuit
- step on the brake pedal

The alarm will last approximately 150 seconds in the form of blinking exterior lamps. At the same time an additional horn will sound intermittently for 60 seconds, pause for 30 seconds, and repeat for another 60 seconds.

The alarm will stay on even if the activating element (a door, for example) is immediately closed.

Note:

If the radio is removed from its mounting when the anti-theft alarm is armed the radio will automatically be rendered inoperative! (This is indicated by a dashed line across the display.)

Do not give the master key to an unauthorized person. We recommend that you carry the flat key safely with you so that it is always handy. This key has the same function as the master key.

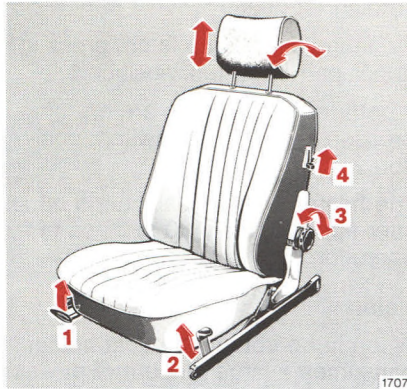

Seat Adjustment

Fore/aft adjustment: lift handle (1); slide seat to the desired position and release handle to re-engage.

Seat elevation (6 positions): Each time handle (2) is pulled up, the seat is raised by one notch. If the handle is pushed down completely, the seat will return to its lowest position. Afterwards, the handle can be pulled up to engage the seat in its first position to avoid clicking noise.

Back rest tilt: turn handwheel (3).

After disengaging the stop by lifting lever (4), the back rest can be folded forward.

Warning!

Do not adjust the driver's seat while driving. Adjusting the seat while driving could cause the driver to lose control of the vehicle.

Never ride in a moving vehicle with the seat back reclined. The seat back and seat belts provide the best restraint, when the wearer is in an upright position and the belts are properly positioned on the body.

Height of Head Restraint:

Pull head restraint slightly forward and slide up or down.

Inclination of Head Restraint:

The inclination can be adjusted manually.

Note:

Always adjust head restraint to support the back of the head approximately at ear level before driving. Do not pull up head restraint past the stop.

Caution!

Do not remove head restraints except when mounting seat covers. For this purpose refer to "Practical Hints", page 88. Whenever restraints have been removed be sure to reinstall them before driving.

Important!

Prior to operating the vehicle, the driver should adjust the seat height for proper vision as well as fore/aft placement and seat back angle to insure adequate control, reach, operation, and comfort. The head restraint should also be adjusted for proper height.

Both the inside and outside rear view mirrors should be adjusted for adequate rearward vision. Fasten seat belts. Infants and small children should be seated in a properly secured restraint system that complies with Federal Motor Vehicle Safety Standard 213.

All seat, head restraint, and rear view mirror adjustments as well as fastening of seat belts should be done before the vehicle is put into motion.

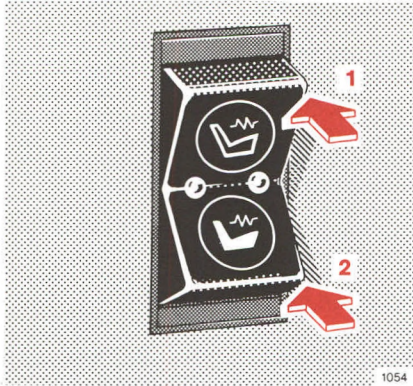

Heated Seats

The heaters can be switched on with the key in steering lock position 1 or 2.

Heater operation:

Push in upper switch portion; position 1 = normal heater operation, one indicator lamp lights up.

Push in lower switch portion; position 2 = rapid heating, both indicator lamps light up.

After approximately 5 minutes in the rapid heating mode, the heater automatically switches to normal operation and only one indicator lamp will stay on.

Turning off heater:

If one indicator lamp is on, press in upper part of switch, position 1.

If both indicator lamps are on, press in lower part of switch, position 2.

The heater automatically turns off after approximately 30 minutes of operation.

Note:

When in operation, the seat heater consumes a large amount of power. It is advisable not to use the seat heater longer than necessary.

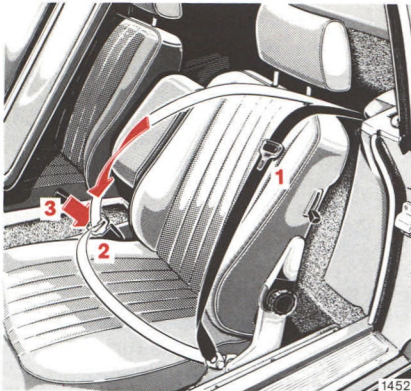

Supplemental Restraint System – Seat Belts, Emergency Tensioning Retractors, Driver Air Bag

Seat Belts and Emergency Tensioning Retractor

Your vehicle is equipped with seat belts and emergency tensioning retractors for all seats. The tensioning retractors are located in each belt's inertia reel and become operationally ready with the key in steering lock position 1 or 2.

Important!

Laws in your state may require seat belt use.

Seat Belt Warning System:

The indicator is illuminated for 4 – 8 seconds after turning the key to steering lock position 2. If the seat belt of the driver's seat is not fastened a warning buzzer sounds simultaneously.

Fastening:

- Pull belt with latch plate (1) across shoulder and lap. Do not twist the belt doing this.
- Push latch plate (1) into buckle (2) until it clicks.
- The belt must be pulled snug and checked for snugness immediately after engaging it and during driving. If necessary, tighten the lap portion to a snug fit by pulling shoulder portion up.

Unfastening:

- Push in the red button (3) in the belt buckle.
- The retractor should completely rewind the belt and latch plate (1).

Operation:

The inertia reel stops the belt from unwinding during sudden vehicle stops or when quickly pulling on the belt.

The emergency tensioning retractor tightens the seat belt upon severe frontal impacts within the shaded area shown on page 34.

The locking function of the reel may be checked by quickly pulling out the belt.

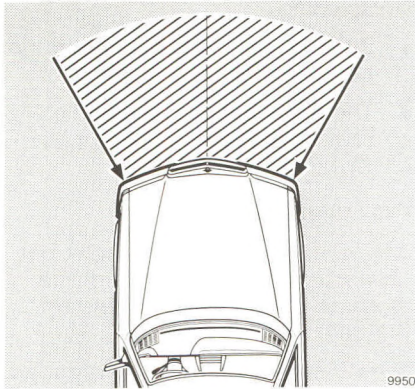

The emergency tensioning retractors are designed to activate only during severe frontal impacts within the shaded area shown. They tighten the belts in such a way that they fit more snugly against the body restricting as much as possible its forward movement.

In cases of less severe frontal impacts, roll-overs, side or rear collisions, or other accidents without severe frontal forces, the emergency tensioning retractors will not be activated. The driver and passenger will then be protected by the fastened seat belts and inertia reel in the usual manner.

Warning!

- **Each occupant should wear their seat belt at all times.**

Together with the “SRS” (driver air bag, seat ETR’s and driver side knee bolster), the seat belt offers the best conditions for protection of the body in case of severe frontal impact. Never wear the shoulder belt under your arm or otherwise out of position. Position the lap belt as low as possible around the hips (not the waist).

- **Infants and small children should be seated in a properly secured child or infant restraint system.**
- **Each seat belt should not be used for more than one person at a time.**
- **Belts should not be worn twisted.**
- **For pregnant women, the lap belt should be positioned as low as possible around the hips, to avoid any possible pressure on the abdomen.**

For cleaning and care of the seat belts, see page 85.

For seat belt and emergency tensioning retractor safety rules, see page 36.

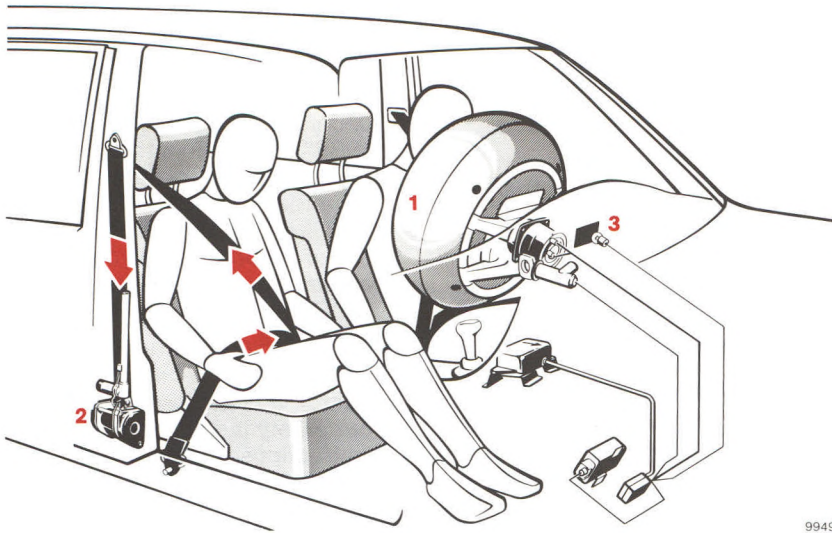

9949

Driver Air Bag

The air bag (1) is located in the steering wheel hub and, in conjunction with wearing the seat belts with emergency tensioning retractors (2), provides increased protection for the driver.

The operational readiness of the supplemental restraint system (air bag and ETR's) is verified by the indicator lamp "SRS" (3) in the instrument cluster. When the key is turned from steering lock position 0 to position 1 or 2, the electronic components of the "SRS" are monitored and undergo a self-check indicated by the "SRS" warning lamp coming on. If no fault is detected, the lamp will go out after approximately 10 seconds.

After the lamp goes out, the system continues to monitor the components and circuitry of the "SRS" and will indicate a malfunction by coming on again.

We strongly recommend that you visit an authorized MERCEDES-BENZ dealer immediately to have the system checked; otherwise the "SRS" may not be activated in a severe frontal accident.

Important note:

The air bag is designed to activate only in severe frontal impacts within the shaded area shown in the illustration on page 34. Only during these types of impacts will it provide its supplemental protection. The driver should always wear the seat belt, otherwise it is not possible for the air bag to provide its intended protection.

In cases of less severe frontal impacts, roll-overs, side or rear collisions, or other accidents without severe frontal forces, the air bag will not be activated. The driver and passenger will then be protected by the fastened seat belts.

The activation of the “SRS” temporarily releases a small amount of dust from the driver air bag and the seat belt emergency tensioning retractors. This dust, however, is neither injurious to your health, nor does it indicate a fire in the vehicle.

The service life of the air bag extends to the date indicated on the sticker on the inside of the glove compartment door and on the radiator cowl. To provide continued reliability after that date, it should be inspected by an authorized MERCEDES-BENZ dealer at that time.

Safety Guidelines for the Supplemental Restraint System – Seat Belts, Emergency Tensioning Retractor and Air Bag

Warning!

- **Damaged belts or belts that were highly stressed in an accident must be replaced and their anchoring points must also be checked. Use only belts installed or supplied by MERCEDES-BENZ.**
- **Do not pass belts over sharp edges.**
- **Do not make any modification that could change the effectiveness of the belts.**
- **An air bag or tensioning retractor that was activated must be replaced.**
- **No modifications of any kind may be made to any components or wiring of the “SRS”. This includes the installation of additional trim material, badges, etc. over the steering wheel hub and installation of additional electrical/electronic equipment on or near “SRS” components and wiring.**

- **Improper work on the system, including incorrect installation and removal, can lead to possible injury through an uncontrolled activation of the “SRS”. In addition, through improper work there is the risk of rendering the “SRS” inoperative. Work on the “SRS” must therefore only be performed by an authorized MERCEDES-BENZ dealer.**
- **When scrapping the air bag unit or emergency tensioning retractor, it is mandatory to follow our safety instructions. These instructions are available at your authorized MERCEDES-BENZ dealer.**

When you sell the vehicle we strongly urge you to give notice to the subsequent owner that it is equipped with an “SRS” by alerting him to the applicable section in the Owner’s Manual.

Infant and Child Restraint Systems

Mercedes-Benz of North America recommends that all infants and children be restrained at all times while the vehicle is in motion.

Important!

The use of infant or child restraints is required by law in all 50 states and Canadian provinces.

Infants and children should be seated in a properly secured restraint system that complies with U.S. Federal Motor Vehicle Safety Standard 213. A statement by the seat manufacturer of compliance with this standard can be found on the instruction label on the restraint and in the instruction manual provided with the restraint.

When using any infant or child restraint system, be sure to carefully read and follow all manufacturer's instructions on installation and use.

Warning!

Infants and small children should never be held on the lap, nor should they share a seat belt with another occupant while the vehicle is in motion.

This vehicle is equipped with tether anchorages for use with child restraints that have a top tether strap. Consult your authorized MERCEDES-BENZ dealer for the exact location of these anchorages.

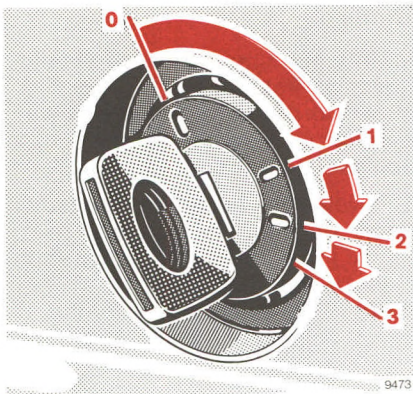

Steering Lock

- 0 Steering is locked when the key is withdrawn and the steering lock is engaged. The key can be withdrawn only in position 0.

Warning!

Do not remove key from the steering lock while the vehicle is in motion as this will cause the engagement of the steering lock thus rendering the vehicle inoperable.

- 1 Steering is unlocked. (If necessary, move steering wheel slightly and turn the key clockwise to position 1.)
- 2 Driving position.
- 3 Starting position.

For starting and turning off the engine, refer to page 15.

Warning!

When leaving the vehicle always remove the key from the steering lock. Do not leave children unattended in the vehicle. Unsupervised use of vehicle equipment may cause serious personal injury.

Notes:

The following items can be operated with the key in steering lock position 1:

Wiper, windshield washer, headlamp flasher, lighter, glove compartment lamp, radio, heated seats, electrically adjustable exterior mirror.

A warning buzzer sounds when the driver's door is opened with the key in steering lock position 1 or 0.

With the engine at idle speed, the charging rate of the alternator (output) is limited.

It is therefore recommended to turn off unnecessary electrical consumers while driving in stop and go traffic. This precaution helps to avoid draining of the battery.

Unnecessary strain on the battery and charging system may be minimized by turning off the following power consumers, for example: Heated seats, rear window defroster.

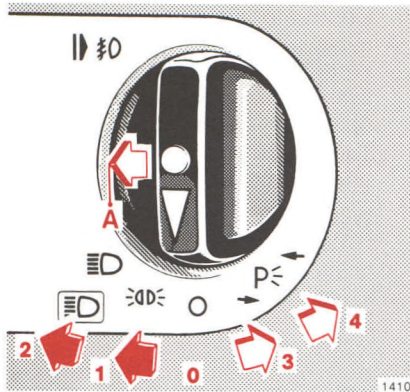

Exterior Lamp Switch

- 0 Off-position
- 1 Parking lamps (includes side marker lamps, taillamps, license plate lamps, instrument panel lamps)
- 2 Same as pos. 1 plus headlamps
- 3 Standing lamps, right
- 4 Standing lamps, left
- A Fog lamps (turn to position 2 and pull out to first stop = same as position 2 plus fog lamps).

Standing lamps

When the vehicle is parked on the street the standing lamps (right or left side parking lamps) can be turned on, making the vehicle more visible to passing vehicles.

The standing lamps can only be operated with steering lock in position 0 or 1.

Notes:

With the key removed and the driver's door open, a warning buzzer sounds if the vehicle's exterior lamps are not switched off (except standing lamps).

Fog lamps will only operate together with low beam headlamps. Fog lamps are turned off automatically when the exterior lamp switch is returned to the off-position.

Consult your state Motor Vehicle Regulations regarding fog lamp operation.

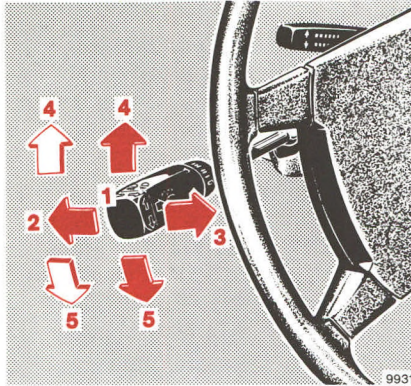

Combination Switch

- 1 Low beam (with exterior lamp switch turned to position 2)
- 2 High beam (with exterior lamp switch turned to position 2)
- 3 High beam flasher (high beam available independent of exterior lamp switch position)
- 4 Turn signals, right
- 5 Turn signals, left

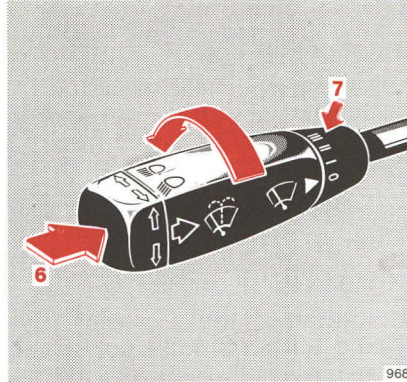

- 6 Control for windshield washer system
When the washer system is switched on, the wipers also operate.
The windshield washer nozzles are automatically heated.
- 7 Windshield wiper control
0 Wiper off
I Intermittent wiping
II Normal wiper speed
III Fast wiper speed

Note:

If one of the turn signals fails, the turn signal indicator system flashes and sounds at a faster rate than normal. In addition, the lamp failure indicator will come on.

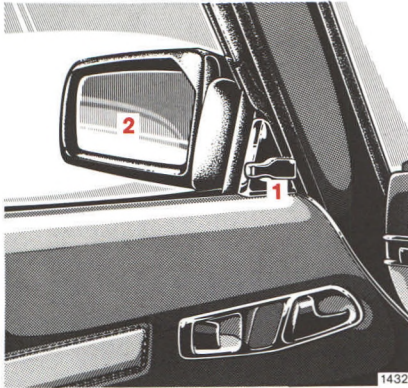

1432

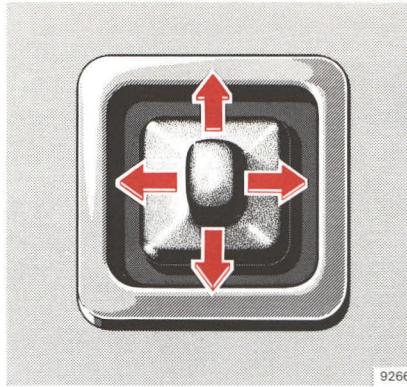

9266

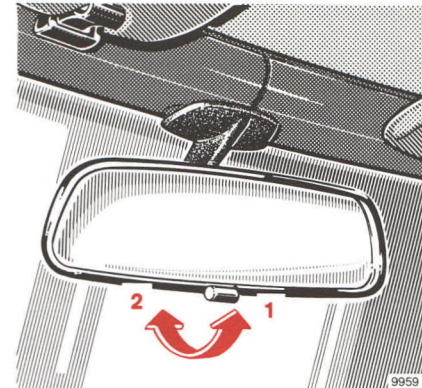

9959

Exterior Rear View Mirrors

The exterior mirrors have electrically heated glass. The heater switches on and off automatically, depending on outside temperature.

Driver's side:

The exterior mirror (2) can be adjusted from inside the vehicle by moving adjusting lever (1) in the desired direction.

Passenger side:

The passenger side exterior mirror is convex (outwardly curved surface). Exercise care when using the passenger side mirror.

Caution!

Objects in mirror are closer than they appear.

To adjust the mirror:

Turn key in steering lock to position 2. The exterior mirror can be adjusted using the switch. Adjust the mirror so you can just see the side of your vehicle in the portion of the mirror closest to the car.

Note:

If the mirror housing is forcibly pivoted from its normal position, it must be repositioned by applying firm pressure until it snaps into place.

Inside Rear View Mirror

The mirror can be tilted to the anti-glare night position by means of the lever at its lower edge.

1 = Normal position
2 = Anti-glare night position.

Use your inside mirror to determine the size and distance of objects seen in the passenger side convex mirror.

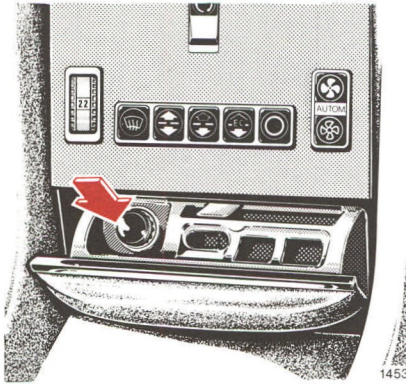

Lighter

Turn key in steering lock to position 1 or 2.

Push in lighter; it will pop out automatically when hot.

Warning!

Do not touch heating element or sides of lighter, hold at knob only.

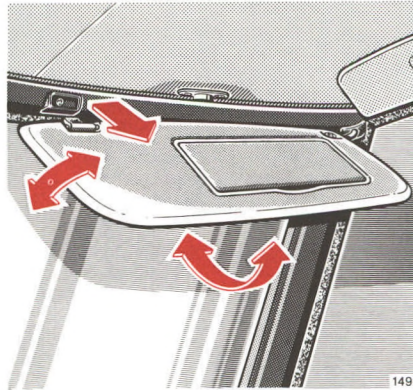

Sun Visors

Swing sun visors down to protect against sun glare.

If sunlight enters through a side window, disengage visor from inner mounting and swing to the side.

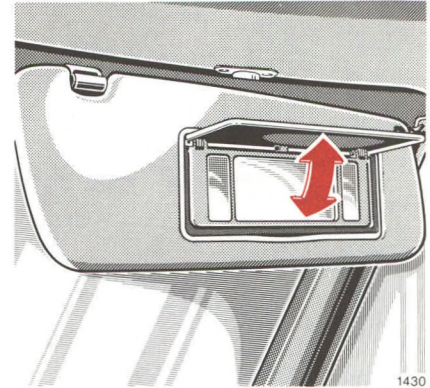

Vanity mirror:

With the visor engaged in its inner mounting, the lamp can be switched on by opening the cover.

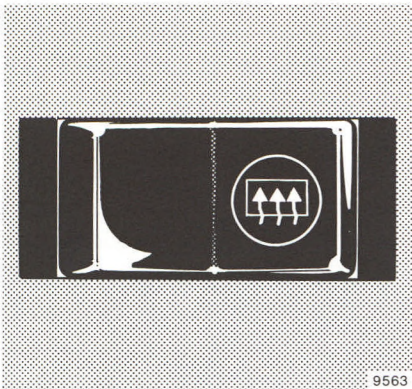

Rear Window Defroster (Hardtop only)

With engine running, press symbol side of rocker switch to turn on, press left side to turn off.

When activating the rear window defroster, the indicator lamp in the switch will come on.

Note:

The rear window defroster uses a large amount of power. To keep the battery drain to a minimum, turn off the defroster as soon as the window is clear. The defroster is automatically turned off after a maximum of 20 minutes of operation. Heavy accumulation of snow and ice should be removed before activating the defroster.

If several power consumers are turned on simultaneously, or the battery is only partially charged, it is possible that the defroster will automatically turn itself off. When this happens, the indicator lamp inside the switch starts blinking. As soon as the battery has sufficient voltage, the defroster automatically turns itself back on.



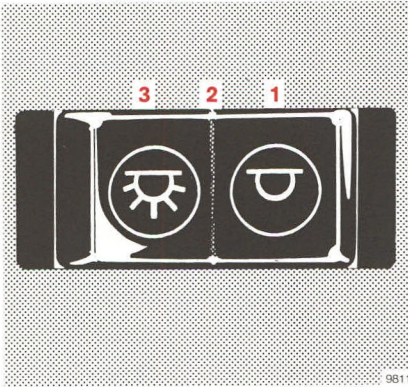

Interior Lamps

The switch for the front dome lamps has 3 positions.

Position 1: the lamps are switched on and off (delayed, however, there will be no delay when the key is in steering lock position 2) by the door contact switches.

Position 2: lamps are switched off continuously.

Position 3: lamps are switched on continuously.

Power Windows

The power windows can only be operated with the key in steering lock position 2.

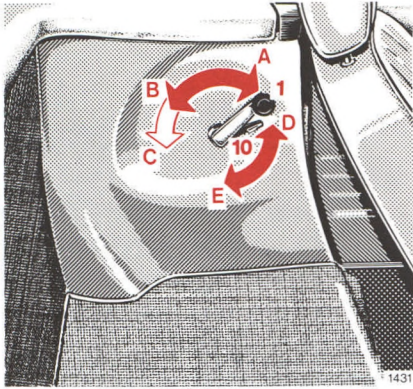

Soft Top

If possible, park vehicle in the shade as continuous exposure to sun rays can prematurely deteriorate the soft top material.

To lower or raise the soft top or to remove or attach the hardtop, there are two locking handles in a bag stowed in the glove compartment. They are used to engage or disengage locks (4). Put locking handles back into the glove compartment after use.

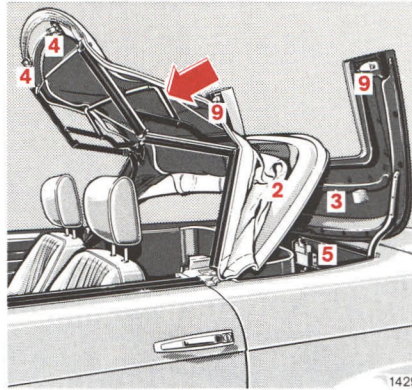

Lowering the soft top:

A wet or frozen top must not be folded until thawed and dry.

Open side windows or doors before raising or lowering the soft top.

1. Unlock rear bow (2) and compartment cover (3) by rotating lever (1) to position C. Lever will automatically return to position B. If the rear bow cannot be raised with lever in this position, move lever (10) to position E.
2. Lift rear bow to an upright position. In doing this, be sure the rear window is folded inward free of kinks.
3. Open top storage compartment cover (3).
4. Disengage top framework at front by turning locks (4) inwards. Remove handle after turning lock.
5. Bring the front bow back. Make sure that the frame bow (arrow) pivots to its rearmost position, to prevent damage to the top.

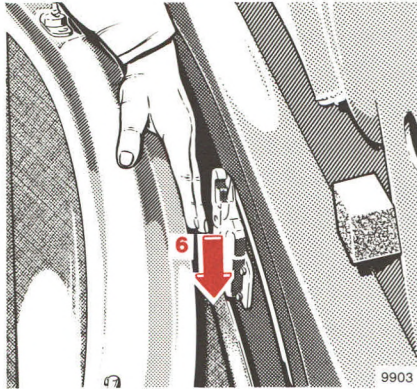

6. Guide the top into its storage compartment (5).

To avoid curling the edges of the soft top, tuck in the edges so that the material is not stored with lifted edges in the following areas:

- (6) under lock,
 - (7) under the left and right hinge area,
 - (8) at the left and right side area.
7. Return safety lever to position D.

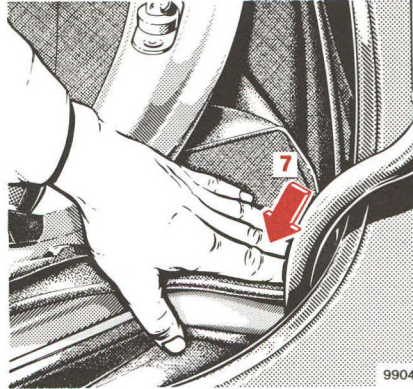

8. Close top storage compartment cover, making sure that both sides (9) are locked.

Raising the soft top:

1. Rotate lever (1) to position C and open storage compartment cover (3).
2. Pull the top out of the storage compartment, unfolding it forward to insert the locks (4) in their corresponding latching holes in the windshield header bar.

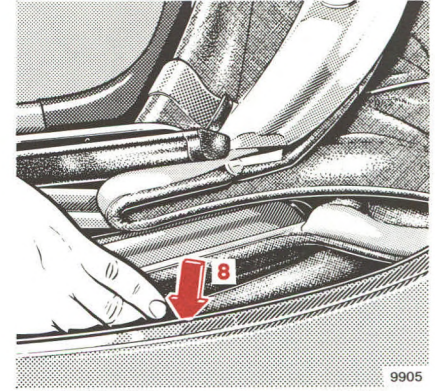

3. While pulling top down tighten framework by turning locks (4) outwards. Remove locking handles.
4. Close top storage compartment cover, making sure that both sides (9) are locked.
5. Fold down top until rear bow locks in place in the center, then tighten rear bow with crank (1) (position A). Lever (10) must be in position D.

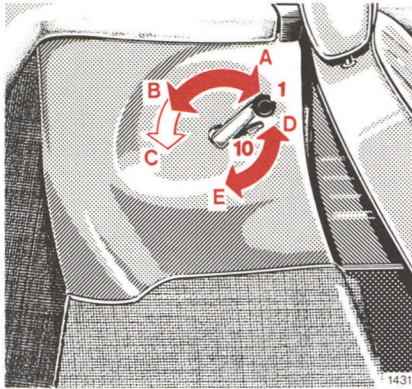

Removal or attachment of the hardtop is best done at an authorized MERCEDES-BENZ dealer, although this can be carried out by 2 persons.

The soft top must be completely dry before it is placed in the storage compartment.

To remove or attach the hardtop, there are two locking handles in a bag stowed in the glove compartment.

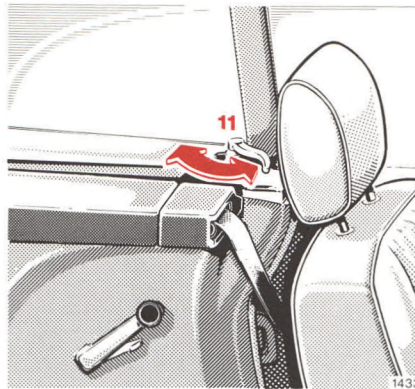

They are used to engage or disengage the locks in the windshield header bar and behind the doors (11). Put locking handles back into the glove compartment after use.

The hardtop has five latching points:

Front = two locks in windshield header bar

Side = one lock behind each door (11)

Rear = center locking pin on hardtop.

Removal of hardtop:

1. Disconnect plug and socket of the heated rear window in the passenger side rear compartment.
2. Place lever (1) in position B, lever (10) in position E.
3. Turn side locks (11) rearwards to the stop with locking handles.
4. Insert locking handles into windshield header bar locks and turn inwards. Remove locking handles.
5. Lift the top carefully from its five latching holes and remove to the rear.



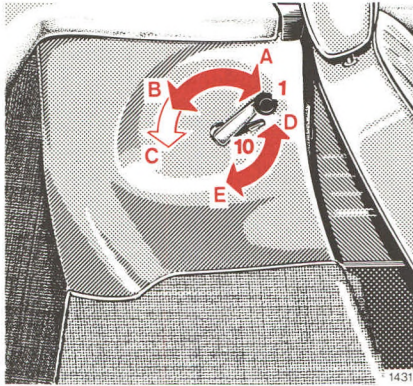

Attaching hardtop:

1. Move lever (1) to position B and lever (10) to position D.
2. Install hardtop with caution to avoid paint damage. Lower hard top slowly. All locking pins should be engaged into their respective locks at the same time.

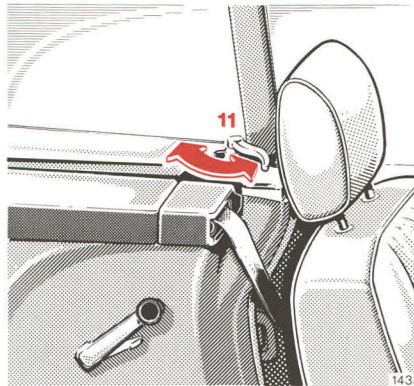

3. Insert both locking handles into the forward locks and swing outwards.
4. Insert locking handles into side locks (11) and turn completely forward to the stop.
5. Move lever (1) to position A.
6. Connect plug and socket of the heated rear window in the passenger side rear compartment.

The soft top may become moldy if it is kept enclosed in the storage compartment for an extended period. Unfold and air it thoroughly (do not expose to the sun) at regular intervals during the wet and cold seasons.

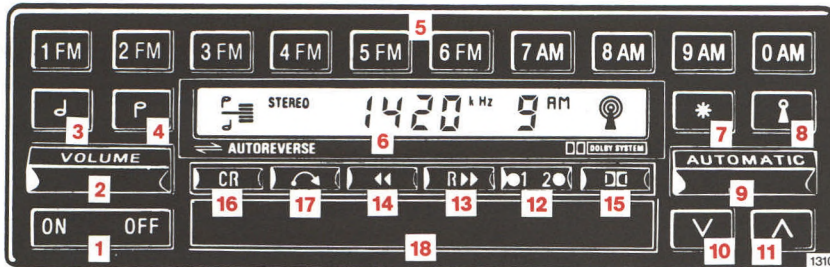

Electronic Radio

Pushbutton Functions

- 1 On/Off button **ON OFF**
- 2 Volume control **VOLUME**
- 3 Bass control **B**
- 4 Treble control **T**
- 5 Pushbuttons for AM/FM band selection, station frequency selection, station storage **1 FM** through **0 AM**
- 6 Digital display for station frequency (a), station pushbutton number (b), AM/FM band (c), stereo indicator (d), tone setting indicator (e), tuning sensitivity indicator (f)

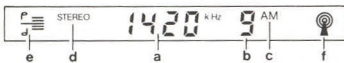

- 7 Function control
- 8 Tuning sensitivity
- 9 Automatic station seeker bar
- 10 Manual tuning **▼** (decreasing station frequency)
- 11 Manual tuning **▲** (increasing station frequency)
- 12 Cassette track selector and track indicator **1 2**
- 13 Fast tape rewind **R▶▶**
- 14 Fast tape forward **◀◀**
- 15 Dolby* noise reduction **DD**
- 16 Tape selection **CR**

* Dolby and the double-D symbol are trademarks of Dolby Laboratories Licensing Corporation.

Noise reduction system manufactured under license from Dolby Laboratories Licensing Corporation.

- 17 Cassette eject **⏏**
- 18 Cassette door

To turn the radio ON

Press “ON” side of **ON OFF** button. The radio will begin operating on the last station, volume and tone setting stored before last turning it off.

The system can also be turned on by inserting a tape cassette through the cassette door.

To turn the radio OFF

Press the “OFF” side of the **ON OFF** button.

Volume adjustment

To reduce volume, press volume button **VOLUME** downward; to increase volume, press volume button **VOLUME** upward.

To adjust the tone characteristic

Base **B** and treble **T** can be adjusted independently.

To set the radio to a “flat” response (bass and treble at mid-range setting), briefly press both tone controls **B** and **T** simultaneously. The tone setting indicator shows the selected response:

$\frac{T}{B} \equiv \equiv$ = Flat Response

Upon pressing either tone button, the level for that function (either **B** or **T**) will begin increasing. It stops increasing when the button is released or when the maximum tone level is reached:

$\frac{T}{B} \equiv \equiv \equiv$ = Maximum Treble

$\frac{B}{T} \equiv \equiv \equiv$ = Maximum Bass

After reaching the maximum tone level, the tone control will stay at that level unless the tone button is released and pressed again, at which point the tone level will start decreasing. It will stop decreasing when the button is released or when the minimum tone level is reached.

$\frac{T}{B} \equiv$ = Minimum Treble

$\frac{B}{T} \equiv$ = Minimum Bass

After reaching the minimum tone level, the tone control will stay at that level unless the tone button is released and pressed again. After pressing the tone button again the tone level will begin to increase and the cycle is repeated.

Note: It takes approximately 5 seconds to go from minimum tone level to maximum tone level.

To select AM or FM

Press any of the buttons marked **1 FM** through **6 FM** to tune the radio to the FM band.

Press any of the buttons marked **7 AM** through **0 AM** to tune the radio to the AM band.

The selected wave band is shown in the digital display.

To tune in a station

Stations can be tuned in by using automatic seek, direct frequency tuning, manual tuning, or by preset pushbuttons. The frequency of the station selected is indicated on the digital display.

Automatic station seeker



Switch to the wave band desired by pressing any of the following buttons:

for FM, buttons **1 FM** through **6 FM**,
for AM, buttons **7 AM** through **0 AM**.

By pressing the automatic station seeker bar **AUTOMATIC** upward the radio will seek stations in ascending frequencies, by pressing down it will do so in descending frequencies. The direction of automatic seeking can be reversed by pressing the bar **AUTOMATIC** in the respective direction. In order to arrive at a desired station without stopping, the bar must be held in the desired direction.

Tuning sensitivity button

By pressing the tuning sensitivity button  once or twice, you can select the desired sensitivity level of the automatic station seeker. The sensitivity indicator shows the selected sensitivity level:

-  = least sensitive (the automatic seeker only stops at strong stations)
 -  = average (the automatic seeker stops at strong and moderate strength stations)
 -  = most sensitive (the automatic seeker also stops at weak stations)
- When switched off, the radio returns to the “least sensitive” level.

Direct frequency tuning

In order to select a station with a known frequency, select the wave band (AM or FM), press the function control button  and then enter the frequency by pressing the corresponding pushbuttons.

Example:

Press any button marked

FM 98.5 MHz	AM 1050 kHz
 through 	 through 
	
  	   

Press the function control button

Enter frequency by pressing

When tuning a frequency directly, the number of the pushbutton is not displayed on the panel. The wave band is indicated by showing “MHz” for FM or “kHz” for AM.

Note:

All AM stations have allocated frequencies ending with a “0”.

All FM stations have allocated frequencies ending with an odd (uneven) digit after the decimal point.



Broadcasters sometimes may not give their exact frequency but the next closest whole number.

US radio frequency ranges:

AM 540–1600 kHz

FM 88.1–107.9 MHz





Manual tuning (used to fine tune a station or for manual scanning)

After selecting the desired AM or FM wave band, press the manual tuning button  (decreasing station frequency) or  (increasing station frequency).



The frequency will increase or decrease respectively in increments of 0.1 MHz for FM or 1.0 kHz for AM. Release the button when the desired station is tuned in.

Please note: It is recommended that manual tuning operations be performed by the driver while the vehicle is not in motion.

Pushbutton tuning

Six FM stations and four AM stations can be stored in memory and recalled by pressing the appropriate buttons marked  through  for FM or  through  for AM stations.

To store stations in memory

Any FM station can be stored on any button marked  through  by first tuning in the desired station, depressing the button desired and holding it until the display has changed from the “old” setting to a “blank” and then to the new station to be stored.

Showing the “old” setting first allows for reconsideration of the decision to store. If it is desirable to leave the “old” station in memory rather than exchanging it with the “new” one, quickly release the button. The “old” station will remain in memory.

Any AM station can be stored similarly on any button marked **7 AM** through **0 AM**.

Stereo reception

The stereo indicator **STEREO** lights up if a stereo program in the AM or FM band is received.

Note: Since some AM stereo broadcasting is not compatible with your car radio reception capabilities, you may experience limited AM stereo reception in some areas. The radio receives AM stereo programs which are broadcast via the C-Quam^{®*} AM stereo system.

The radio is equipped with an automatic stereo/mono switch that electronically switches to mono for clear reception if a weak signal is received.

The stereo indicator will remain lit even if the receiver has changed to the mono mode and will turn off at an antenna signal considered insufficient to provide acceptable reception quality.

Note: Although FM is normally static free, reception quality can be limited by geographic and atmospheric conditions, station strength and distance from transmitter. Buildings or other obstructions can cause momentary static, flutter or station swapping. If good reception cannot be obtained, tune to a stronger station.

Tape cassette playback



It is recommended to use only good quality cassettes with a playback time of not more than 90 minutes (C 90).

To start playback, insert a cassette (tape side first, side “1” or “A” facing up) through the cassette door. Push the cassette in until it is locked in its playing position.

When the end of one playing side is reached, the unit switches automatically to reverse for playing the second track.

The tape track can be selected by depressing the cassette track button **01 2**. The built-in indicators show which track of the cassette the unit is playing back.

To stop playback, press the eject button . The unit will automatically eject the cassette and switch to radio reception.

For fast tape rewind press the fast rewind button . The button will lock into position until the end of the tape is reached or until the eject  or fast forward button  is activated.



Accordingly, for fast forward of the tape, press the fast forward button .

To replay cassettes recorded using the Dolby B noise reduction system, the Dolby NR button  should be pressed in. This reduces tape hiss.

When the radio is turned off by pressing the “OFF” side of the **ON OFF** button or by turning the key to steering lock position 0, the cassette will automatically be ejected.

* C-Quam[®] is a registered trademark of Motorola, Inc.

Tape equalization

For good reproduction quality it is necessary to adjust the tape player for the particular type of tape being used. Press the CR button  for Chromium dioxide (CrO₂) or “metal” cassette tapes only. For all other types of tapes, the CR button  should be out.

Care and maintenance

To avoid deterioration of the tone quality clean the tape head with the special cleaning tape available through your authorized MERCEDES-BENZ dealer.

Radio anti-theft protection

Removal of the radio with the vehicle anti-theft alarm armed will render the radio inoperative indicated by a dashed line across the display.

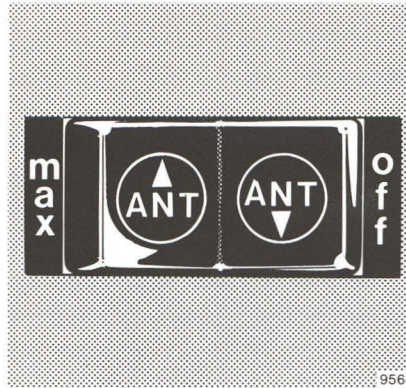

Automatic Antenna

The antenna switch can be actuated with the radio switched on.

- If the antenna switch is engaged in the “max” position, the antenna extends fully.

Note:

For most conditions the antenna should normally be in this position.

- If the antenna switch is in the center position, the antenna extends automatically to medium height,
- if the antenna switch is engaged in the “off” position, the antenna will not extend or will retract completely.

The height of the antenna can be adjusted to any intermediate position by actuating the antenna switch:

- If the antenna switch is in the center position, the antenna will extend to medium height. The antenna can be further extended or retracted to any height by rocking the switch (not engaging it).
- If the antenna is to be retracted, e.g. going through car wash, etc., engage switch in “off” position.

When the key is turned to steering lock position 0 or the radio is turned off, the antenna will retract completely.

Driving

Parking Brake	56
Automatic Transmission	56
Cruise Control	59
ABS (Antilock Brake System)	60
Brake Pad Wear Indicator Lamp	61
Brake Warning Lamp	61
Charge Indicator Lamp	61
Oil Pressure Gauge	61
Low Engine Oil Level Indicator Lamp	61
Exterior Light Failure Indicator Lamp	62
Fuel Reserve Warning Lamp	62
Coolant Temperature Gauge	62
Low Engine Coolant Level Indicator Lamp	62
Low Water Level Indicator Lamp for Windshield Washer System	62
Outside Temperature Indicator	63
Emission Control	63
Economical Driving Indicator (ECONOMY)	64
Deceleration Shutoff	64
Engine Oil Consumption	64
Traveling Abroad	64
Winter Driving	65
Tire Chains	65

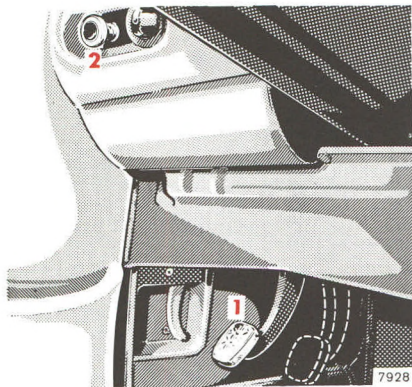

Parking Brake

To engage, depress parking brake pedal (1). When the key is in steering lock position 2, the brake warning lamp in the instrument cluster should come on (function check for brake warning lamp).

To release the parking brake, pull the release knob (2) on the instrument panel. This releases the parking brake pedal under spring pressure and the indicator lamp on the instrument cluster should go out at the same time.

Automatic Transmission

The automatic transmission selects individual gears automatically, dependent upon selector lever position, vehicle speed and accelerator position.

Warning!

Keep driver's foot area clear at all times. Objects stored in this area may impair pedal movement.

Driving:

Shift selector lever to the desired driving position only when the engine is idling and the service brake is applied. Do not release the brake until ready to drive. The vehicle may otherwise start creeping when the selector lever is in a drive position.

Test the brakes shortly after driving off. Perform this procedure only when the road is clear of other traffic.

Warm up the engine smoothly. Do not place full load on the engine until the operating temperature has been reached.

When starting off on a slippery surface, do not allow one driving wheel to spin for an extended period.

Accelerator position

Partial throttle = early upshifting = normal acceleration.

Full throttle = later upshifting = maximum acceleration.

Depressing the accelerator beyond full throttle to kickdown position means downshifting to the next lower gear and thereby increasing acceleration. If you ease up on the accelerator after having attained the desired speed, the transmission will shift up again.

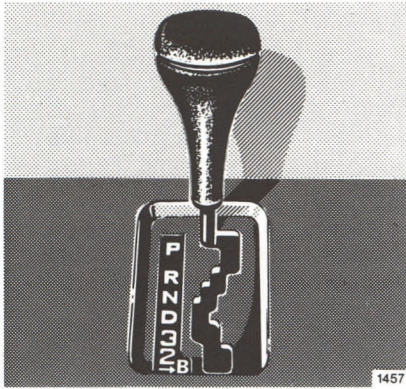

Selector Lever Positions

The automatic gear shifting process can be adapted to specific operating conditions using the selector lever.

- “P” Parking lock.
The parking lock is an additional safeguard to the parking brake when parking the vehicle. Engage only with the car stopped.
- “R” Reverse gear.
Shift to reverse gear only with the car stopped.
- “N” Neutral.
No power is transmitted from the engine to the rear axle. When the brakes are released, the vehicle can be moved freely (pushed, towed or tow-started). Do not engage “N” when driving except when the vehicle is in danger of skidding (e.g. on icy roads, see page 18).

- “D” Drive.
Automatic upshifting to top gear. Position “D” affords optimum driving characteristics under all normal operating conditions.
- “3” Upshift to 3rd gear only. Suitable for medium range up or downgrades.
- “2” Upshift to 2nd gear only. For driving in mountainous regions. Since transmission will not shift up further, this gear selection will make use of the engine’s braking power.
- “B” In this position, the engine’s braking effect is utilized while descending steep or lengthy downgrades. Use this position only below 60 km/h (40 mph).



Important!

Do not exceed the engine speed limits for individual gear selections, which are indicated by marks on the speedometer.

Do not attempt downshifting to a lower gear (braking effect) unless the speedometer needle is below the speed limit mark of that particular gear range. Over-revving could result in damage to the engine.

On slippery road surfaces, it is not recommended to downshift in order to obtain braking action. This could result in rear wheel slip and reduced vehicle control.

To prevent the engine from laboring at low RPMs, do not allow the engine speed to drop too low on uphill gradients. Depending on the degree of the incline, shift selector lever to positions “3” or “2” early enough to maintain engine RPMs within the best torque range.

Stopping

For brief stops, e.g. at traffic lights, leave the transmission engaged and control vehicle with the service brake.

For longer stops with the engine idling, shift into “N” or “P”.

When stopping the car on a slope, do not hold it with the accelerator, use the brake. This avoids unnecessary transmission heat build up.

Maneuvering

To maneuver in tight areas, e.g. when pulling into a parking space, control the car speed by gradually releasing the brakes. Accelerate gently and do not pump the accelerator.

To rock a car out of soft ground (mud or snow), alternately shift from forward to reverse, while applying partial throttle.

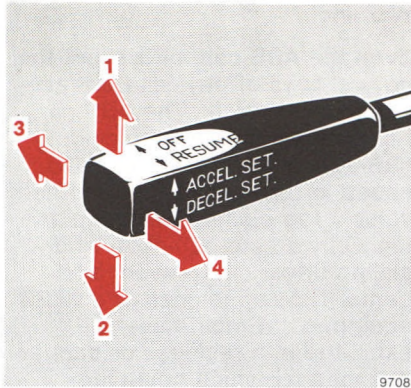

Cruise Control

Any given speed above approximately 40 km/h (25 mph) can be maintained with the cruise control by operating the lever.

- 1 Accelerate and set:
Lift lever briefly to set speed.
Hold lever up to accelerate.
- 2 Decelerate and set:
Depress lever briefly to set speed.
Hold lever down to decelerate.

Normally the vehicle is accelerated to the desired speed with the accelerator. Speed is set by briefly pushing the lever to position 1 or 2. The accelerator can be released.

The speed can be increased (e.g. for passing) by using the accelerator. As soon as the accelerator is released, the previously set speed will be resumed automatically.

If a set speed is to be increased or decreased slightly, e.g. to adapt to the traffic flow, hold lever in position 1 or 2 until the desired speed is reached. When the lever is released, the newly set speed remains.

3 Cancelling

To cancel the cruise control, briefly push lever to position 3.

When you step on the brake pedal or the vehicle speed falls below approx. 40 km/h (25 mph), for example when driving upgrade, the cruise control will be cancelled.

4 Resume

If the lever is briefly pulled to position 4 when driving at a speed exceeding approximately 40 km/h (25 mph), the vehicle resumes the speed which was set prior to the cancellation of the cruise control. The last memorized speed is cancelled when the key is turned to steering lock position 1 or 0.

Note:

If the engine does not brake the vehicle sufficiently while driving on a downgrade, the speed you set on the cruise control may be exceeded. As soon as the grade eases, the cruise controlled speed will again be maintained as long as the brakes were not applied.

If the set speed was sufficiently exceeded such that the brakes had to be applied, the cruise control can be resumed by pulling the lever to position 4.

Warning!

Only use the cruise control if the traffic and weather conditions make it advisable to travel at a steady speed.

The “Resume” function should only be operated if the driver is fully aware of the previously set speed and wishes to resume this particular preset speed.

When driving with the cruise control, the transmission selector lever must not be shifted to position “N” as otherwise the engine will overrev.

ABS (Antilock Brake System)

The ABS prevents the wheels from locking up above a speed of approx. 3 km/h (2 mph) independent of road surface conditions. It is necessary, however, that a speed of approx. 8 km/h (5 mph) has been exceeded at least once after start-up.

At the instant one of the wheels is about to lock up, you will feel a slight pulsation in the brake pedal, indicating that the ABS is in the regulating mode.

On slippery road surfaces, the ABS will respond even with only slight brake pedal pressure. The pulsating brake pedal can be an indication of hazardous road conditions, and it functions as a reminder to take extra care while driving.

The ABS (ANTILOCK) indicator lamp in the instrument cluster comes on with the key in steering lock position 2 and should go out with the engine running.

If the charging voltage falls below 10 volts, the indicator lamp comes on and the ABS is switched off. When the voltage is above this value again, the indicator lamp should go out and the ABS will be operational.

If the ABS indicator lamp does not go out or comes on while driving, it indicates that the ABS has detected a malfunction and has switched off. In this case, the brake system functions in the usual manner, but without antilock assistance. We recommend that you visit an authorized MERCEDES-BENZ dealer as soon as possible to have the system checked.

Warning!

Even the ABS cannot prevent the natural laws of physics from acting on the vehicle. The ABS cannot prevent accidents, including those resulting from excessive speed in turns, following another vehicle too closely, or aquaplaning. Only a safe, attentive, and skillful driver can prevent accidents. The capabilities of an ABS equipped car must never be exploited in a reckless or dangerous manner which could jeopardize the user's safety or the safety of others.

Brake Pad Wear Indicator Lamp

The brake pad wear indicator lamp in the instrument cluster comes on when the key in the steering lock is turned to position 2 and it should go out when the engine is running. If the indicator lamp lights up during braking, this shows that the front wheel brake pads are worn down.

Have the brake system checked at an authorized MERCEDES-BENZ dealer as soon as possible.

Brake Warning Lamp

The brake warning lamp will come on if insufficient brake fluid is in the reservoir (key in steering lock position 2 and parking brake released).

When the minimum mark on the reservoir is reached, have the brake system checked (brake pad thickness, leaks).

To test the brake warning lamp, depress the parking brake pedal. Turn key in steering lock to position 2 and the brake warning lamp should come on; release parking brake and the lamp should go out.

Charge Indicator Lamp

Should the charge indicator lamp fail to come on prior to starting when the key is in steering lock position 2 or should it fail to go out after starting or during operation, this indicates a fault which must be repaired at an authorized MERCEDES-BENZ dealer as soon as possible.

Oil Pressure Gauge

The oil pressure at idle speed may drop to 0.3 bar (4.4 psi) if the engine is at operating temperature. This will not jeopardize its operational reliability. Pressure must, however, rise immediately upon acceleration.

Low Engine Oil Level Indicator Lamp

The indicator lamp comes on with the key in steering lock position 2 and should go out when the engine is running.

If it comes on with the engine running and at operating temperature, the oil level has dropped to the minimum mark on the dipstick. When this occurs, the indicator lamp will first come on intermittently and then stay on if the oil level drops further. If no oil leaks are noted and there is no loss in engine oil pressure, continue to drive to the nearest service station where the engine oil should be topped to the "full" mark of the dipstick (see page 70).

In addition to the indicator lamp, the engine oil level should be periodically checked with the dipstick, for example during a fuel stop, or before a long trip (see page 70).

Exterior Light Failure Indicator Lamp

The light failure indicator comes on with the key in steering lock position 2 and will go out when the engine starts.

If it comes on with the engine running, it indicates a light failure.

If an exterior light fails, the indicator will come on only when that light is switched on.

If a brake or turn signal lights fails, the light failure indicator will come on when applying the brake or actuating the turn signal and stay on until the engine is turned off.

Caution!

If additional lighting equipment is installed (e.g. auxiliary headlamps etc.), be certain to connect into the fuse before the failure indicator monitoring unit in order to avoid damaging the system.

Fuel Reserve Warning Lamp

The fuel reserve warning lamp will come on when the key is turned to steering lock position 2, and will go out after the engine is running.

If the warning lamp stays on after the engine starts, or comes on while driving, it indicates that the fuel level is down to the reserve quantity (11.5 l [3.0 US gal]).

Coolant Temperature Gauge

If the antifreeze mixture is effective to -30°C (-22°F), the boiling point of the coolant in the pressurized cooling system of your vehicle is approx. 125°C (257°F) (see also "Fuels, Coolants, Lubricants, etc.").

During severe operating conditions and stop-and-go city traffic, the coolant temperature may rise close to the red marking.

Low Engine Coolant Level Indicator Lamp

The indicator lamp comes on with the key in steering lock position 2 and should go out when the engine is running.

If it comes on with the engine running, the coolant has dropped below the required level. If no leaks are noticeable and the engine temperature does not increase, continue to drive to the nearest service station and have coolant added to the coolant system (see page 69).

Low Water Level Indicator Lamp for Windshield Washer System

The indicator lamp comes on with the key in steering lock position 2 and should go out when the engine is running.

If it comes on with the engine running, the level of the reservoir has dropped to about $\frac{1}{4}$ of the total volume and should be filled again with washer fluid to which about 1 capful of MB auto-shampoo has been added.

Outside Temperature Indicator

The temperature sensor is located in the front bumper area. Due to its location, the sensor can be affected by road or engine heat during idling or slow driving. This means that the accuracy of the displayed temperature can only be verified by comparison to a thermometer placed next to the sensor, not by comparison to external displays (i.e., bank signs, etc.).

Adaptation to ambient temperature takes place in steps and depends on the prevailing driving conditions (stop and go or moderate, constant driving) and amount of temperature change.

Warning!

The outside temperature indicator is not designed to serve as an Ice-Warning-Device and is therefore unsuitable for that purpose. Indicated temperatures just above freezing point do not guarantee that the road surface is free of ice.

Emission Control

Certain systems of the engine serve to keep the toxic components of the exhaust gases within permissible limits required by law.

These systems, of course, will function properly only when maintained strictly according to factory specifications. Any adjustments on the engine should, therefore, be carried out only by qualified MERCEDES-BENZ technicians. The adjustments of the engine should not be altered in any way. Moreover, the specified service and maintenance jobs must be carried out regularly according to MERCEDES-BENZ servicing requirements. For details refer to the Maintenance Booklet.

Warning!

Inhalation of exhaust gas is hazardous to your health. All exhaust gas contains carbon monoxide, and inhaling it can cause unconsciousness and lead to death.

Do not run the engine in confined areas (such as a garage) which are not properly ventilated. If you think that exhaust gas fumes are entering the vehicle while driving, have the cause determined and corrected immediately. If you must drive under these conditions, drive only with at least one window fully open.

Economical Driving Indicator (ECONOMY)

The indicator shows the fuel consumption tendency during various driving modes.

High fuel consumption is indicated if the pointer moves into the red area; economical driving is indicated when it is in the black area. The indications should only be compared when driving within the same gear.

Do not compare fuel consumption readings between different gears. The following rule applies: If you drive at equal speeds, the fuel consumption is lower in the higher gear, although in this gear the pointer is more frequently in the red area.

Deceleration Shutoff

The fuel injection process is interrupted only during deceleration, if the driver's foot is fully removed from the gas pedal.

Engine Oil Consumption

Engine oil consumption can only be determined after a certain mileage has been covered. During the break-in period, higher oil consumption may be noticed and is normal.

Traveling Abroad

Abroad, there is a widely-spread MERCEDES-BENZ service network at your disposal. If you plan to travel into areas which are not listed in the index of your dealer directory, you should request pertinent information from your authorized MERCEDES-BENZ dealer.

Winter Driving

Have your car winterized at your authorized MERCEDES-BENZ dealer before the onset of winter.

- Engine oil change: If “year-round” multigrade engine oil is not used, be sure to use an SAE grade based on ambient temperature. For recommended engine oil viscosities refer to “Fuels, Coolants, Lubricants, etc.” and last page.
- Anticorrosion/antifreeze in the coolant: Check anticorrosion/antifreeze protection periodically. For capacity refer to “Fuels, Coolants, Lubricants, etc.”.

- Additive in the windshield washer system: Add winter windshield washer concentrate to the water. Your authorized MERCEDES-BENZ dealer can advise you on the mixing ratios.
- Test battery: Battery capacity drops with decreasing ambient temperature. A well charged battery ensures that the engine can always be started, even at low ambient temperatures.
- Tires: We recommend M+S radial tires on all four wheels for the winter season. Observe permissible maximum speed for M+S radial tires and the legal speed limit.

Tire Chains

Use only tire chains that are tested and recommended by MERCEDES-BENZ. Your authorized MERCEDES-BENZ dealer will be glad to advise you on this subject.

Chains should only be used on the rear wheels. Adhere to the manufacturer’s mounting instructions.

After driving a short distance retighten the mounted chains.

Tire chains should only be driven on snow at speeds not to exceed 50 km/h (30 mph). Remove chains as soon as possible when driving on roads without snow.

For tips on driving on slippery winter roads refer to page 18.



Practical Hints

Hood	68
Checking Coolant Level	69
Adding Coolant	69
Engine Oil Level Check	70
Fluid Level-Automatic Transmission	71
Spare Wheel, Jack, Vehicle Tool Kit	72
Wheels, Tires	73
Changing Wheels	74
Tire Inflation Pressure	75
Headlamp Adjustment	76
Replacing Bulbs	76
Unlocking of Fuel Filler Flap	80
Fuses	80
Battery	81
Spark Plugs	81
Tow-starting and Towing the Vehicle	82
Jump Starting	83
Cleaning and Care of the Vehicle	84
Ashtray	88
Head Restraints	88
Luggage or Ski Racks	89
Spare Parts Service	89

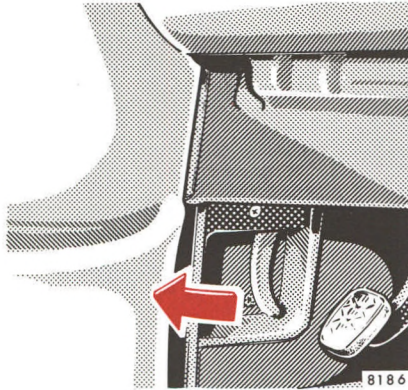

Hood

To open:

Pull hood release handle located on the left side panel below the instrument panel. The hood releases to the safety catch stop.

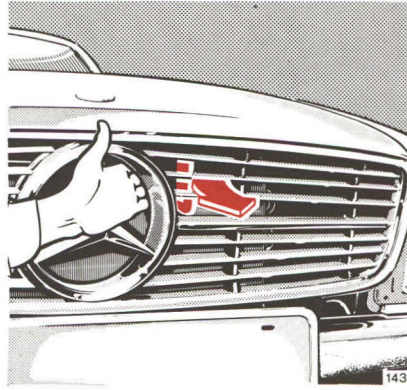

Reach through the opening of the star in the grill and pull the safety catch lever in the direction of the arrow, and raise the hood (be sure that wipers are resting on windshield).

To close:

Push hood down firmly.

Warning!

To help prevent personal injury, stay clear of moving parts when the hood is open and the engine is running. Be sure the hood is properly closed before driving.

The engine is equipped with a transistorized ignition system. Because of the high voltage it is highly dangerous to touch any components (ignition coil, distributor, spark plug sockets, ignition cables, diagnostic socket) of the ignition system

- if the ignition is “on” and the engine turned manually
- while starting the engine
- with the engine running.

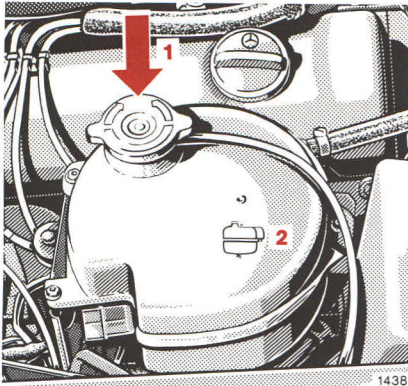

- 1 Coolant reservoir cap
- 2 Marking for coolant level

Checking Coolant Level

The coolant reservoir with filler neck is arranged away from the radiator. To check the coolant level, the vehicle must be parked on level ground.

The coolant level must reach:

- the mark indicated on the reservoir when the coolant is cold
- approximately 2 cm (0.8 in) higher when the coolant is hot.

Adding Coolant

If coolant has to be added, a 50/50 mixture of water and MB anticorrosion/antifreeze should be used.

Warning!

- Use extreme caution when opening the hood, in case there are any signs of steam or coolant leaking from the cooling system.
- Do not remove pressure cap on coolant reservoir if engine temperature is above 90° C (194° F). Allow engine to cool down before removing cap. The coolant reservoir contains hot water/anticorrosion/antifreeze mixture and is under pressure.
- Using a rag, turn cap to first notch to relieve excess pressure. If opened immediately, hot scalding fluid and steam will be blown out under pressure.

The drain plugs are located on the right and left side of the engine and on the radiator bottom.

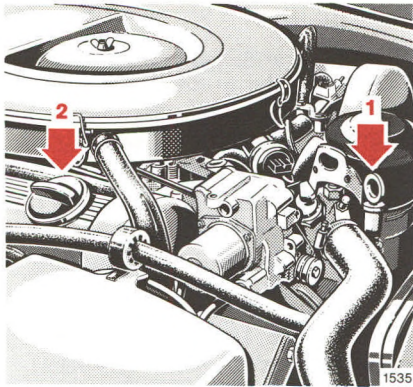

- 1 Oil dipstick
- 2 Oil filler cap

Engine Oil Level Check

The best time to check the engine oil level is when the oil is warm, such as during a fuel stop. With the vehicle on level ground, stop the engine and wait a few minutes for the oil to drain back to the oil pan.

Wipe the dipstick clean before checking.



Add oil, if needed, only to the upper mark (max). Do not overfill the engine.

For viscosity and capacity, see "Fuels, Coolants, Lubricants, etc." and last page.

For low engine oil level indicator lamp, see page 61.

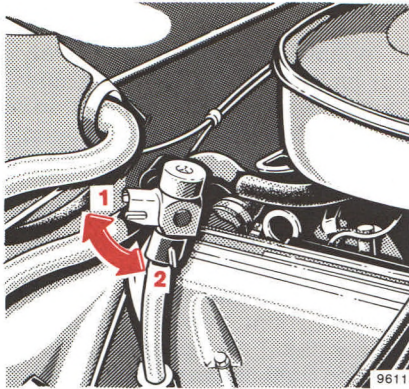

Fluid Level – Automatic Transmission

Check the fluid level in the automatic transmission regularly and prior to an extended trip.

Check transmission fluid level with the engine idling, parking brake engaged and selector lever in position “P”. The vehicle must be parked on level ground. Prior to the check, allow engine to idle for approx. 1 to 2 minutes.

Measure fluid level with the dipstick completely inserted and the locking lever released (1).

Extreme cleanliness must be observed! To wipe the dipstick, use a clean, lint-free cloth. To fill the transmission with fluid, pour it through a fine-mesh filter into the dipstick opening. Even the slightest impurity may cause operational troubles.

The fluid level in the transmission is dependent upon its temperature. The maximum and minimum oil level marks on the dipstick are applicable references only if the transmission fluid has reached its normal operating temperature of 80° C (176° F).

Important!

If the transmission fluid cools down to 20–30° C (68–86° F), which is the normal shop temperature range, then the maximum fluid level will be approximately 10 mm (0.4 in) below the minimum mark on the dipstick. We stress this point because a fluid change is normally performed when the transmission fluid has cooled down to shop temperature.

The fluid level must not exceed the dipstick maximum mark with the fluid at operating temperature. Drain or siphon off excess fluid, if required.

Then push dipstick all the way in and swing locking lever downwards (2).

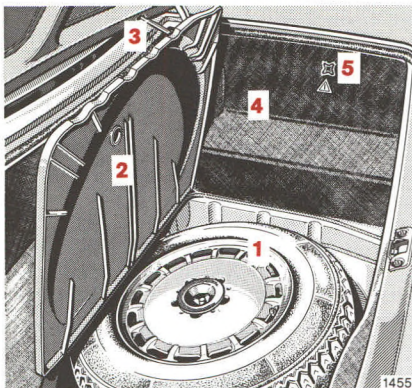

Spare Wheel, Jack, Vehicle Tool Kit

The spare wheel (1) is stored in a compartment below a hinged cover (2) in the trunk floor.

To raise cover, roll back the floor mat and engage holding strap (3) in the trunk lid.

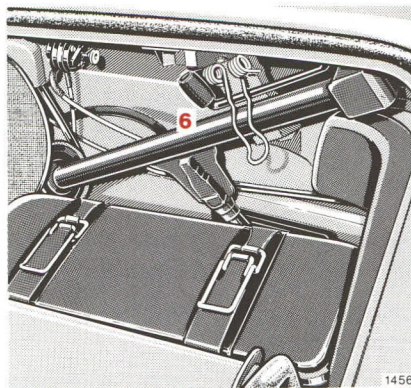

Open cover (4) by turning latch (5) fully to the left.

The jack (6) and tool kit are located behind cover (4). Close hinged cover (2) in the trunk floor before opening.

Warning!

The jack is designed exclusively for jacking up the vehicle at the jack tubes built into either side of the vehicle. Use the jack only to lift the vehicle during a tire change. Never get beneath the vehicle while it is supported only by the jack. Keep hands and feet away from the area under the lifted tire. Jack stands must be used when working under the vehicle. Always set parking brake before raising vehicle with the jack. For details, refer to “Changing Wheels”.

Wheels, Tires

Replace wheels or tires with the same designation, manufacturer and type as shown on the original part. See your authorized MERCEDES-BENZ dealer for further information.

Warning!

Do not mix different tire construction types (i.e. radial, bias, and bias-belted) on your car because handling may be adversely affected and may result in loss of control.

See your authorized MERCEDES-BENZ dealer for information on tested and recommended wheels and tires for summer and winter operation. They can also offer more advice concerning tire service and purchase.

Front tires should be replaced in sets. If possible, the spare tire should be used on the rear wheels. We recommend that you break in new tires for approx. 100 km (60 miles) at moderate speed.

It is imperative that the wheel mounting bolts be retightened after approx. 800 km (500 miles). On new vehicles retightening is carried out during the 1st inspection. Retightening is also necessary whenever wheels are fitted, e.g. when the spare wheel is used for the first time or when a set of wheels with M+S tires are installed.

Tightening torque: 110 Nm (80 lb-ft).

For tire specifications, refer to "Technical Data".

Rotating wheels:

The wheels can be rotated according to the degree of tire wear while retaining the same direction of travel. Rotating, however, should be carried out before the characteristic tire wear pattern (shoulder wear on front wheels and tread center wear on rear wheels) becomes visible at a mileage of 5000–10 000 km (3000–6000 miles) as otherwise the driving properties deteriorate.

Underinflated tires due to a slow leak (e.g. due to a nail in the tire) may cause damage such as tread separation, bulging, etc. Regular tire pressure checks (including the spare tire) at intervals of no more than 14 days are therefore essential. Keep in mind that hot tires have a higher pressure than cold tires. (See tire pressure chart on fuel filler door and the last page.) If a tire constantly loses air, it should be inspected for damage.

Use only genuine MERCEDES-BENZ wheel bolts (identified by Mercedes-Star on bolt shaft).

Thoroughly clean the inner side of the wheels any time you rotate the wheels or wash vehicle underside.

Dented or bent rims cause tire pressure loss and damage to the tire beads. For this reason, check rims for damage at regular intervals.

The rim flanges must be checked for wear before a tire is mounted. Remove burrs, if there are any.

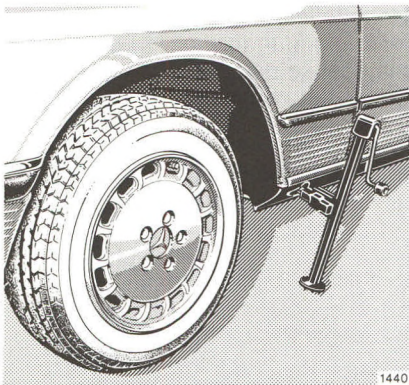

Changing Wheels

1. Set parking brake.
2. Move selector lever to position "P".
3. Prevent vehicle from rolling away by blocking wheels with wheel chocks: When changing a wheel on a hill, place chocks on the downhill side of each wheel of the other axle; on a level road, place one chock in front of and one behind the wheel that is diagonally opposite to the wheel being changed.
4. Using the combination wrench, loosen but do not yet remove the wheel bolts.

5. Clean jack supporting tube, if necessary. (Jack tubes are behind the front wheel housings and in front of the rear wheel housings.)
6. Insert jack arm fully into the tube hole up to the stop. Position the jack so that it will always be vertical as seen from the side, even on inclines. Jack up the vehicle until the wheel is clear off the ground.

Warning!

The jack is designed exclusively for jacking up the vehicle at the jack tubes built into either side of the vehicle. Use the jack only to lift the vehicle during a tire change. Never get beneath the vehicle while it is supported only by the jack. Keep hands and feet away from the area under the lifted tire. Jack stands must be used when working under the vehicle. Always set parking brake before raising vehicle with jack.

7. Then unscrew wheel bolts completely. Keep bolt threads protected from dirt and sand. While removing last bolt, hold

wheel against hub to avoid paint damage on rim.

8. Remove wheel.
9. Screw the alignment stud, which comes with the spare tire, into the upper threaded hole of the hub prior to installing wheel.
10. Adjust the jack height so that the wheel can be slipped on without being lifted.
11. Install spare wheel on wheel hub. Insert wheel bolts and tighten them slightly. To avoid paint damage, place wheel flat against hub and hold it there while installing first wheel bolt. Unscrew the alignment stud to install the last wheel bolt.
12. Lower car and remove jack.
13. Tighten the five bolts evenly by tightening every other bolt until all the bolts are tight. Observe a tightening torque of 110 Nm (80 lb-ft).
14. Correct tire pressure.

Important!

Retighten wheel mounting bolts after approx. 800 km (500 miles). Observe a tightening torque of 110 Nm (80 lb-ft).

Tire Inflation Pressure

A table (see fuel filler flap or last page) lists the tire inflation pressures specified for summer and winter tires as well as for the varying operating conditions.

Important!

Tire pressure differs by approx. 0.1 bar (1.5 psi) per 10° C (18° F) of air temperature change. Keep this in mind when checking tire pressure inside a garage – especially in the winter.

Example:

If garage temperature = approx. +20° C (+68° F)
and, ambient temperature = approx. 0° C (+32° F)
then the adjusted air pressure = specified air pressure + 0.2 bar (3 psi).

Tire pressures listed for light loads are minimum values offering high driving comfort. Increased inflation pressures for heavy loads produce favorable handling characteristics with lighter loads and are perfectly permissible. The ride of the vehicle, however, will become somewhat harder.

Tire temperature and pressure increase with the vehicle speed. Tire pressure should therefore only be corrected on cold tires. Correct tire pressure in hot tires only if pressure has dropped below the pressure listed in the table and the respective operating conditions are taken into consideration.

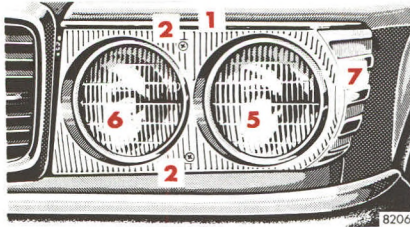

Headlamp Adjustment

Correct headlamp adjustment is extremely important. Check and readjust headlamps at regular intervals and when a lamp has been replaced.

Replacing Bulbs

Only handle new Halogen type bulbs with tissue paper or similar. Install only 12 volt bulbs with the specified watt rating.

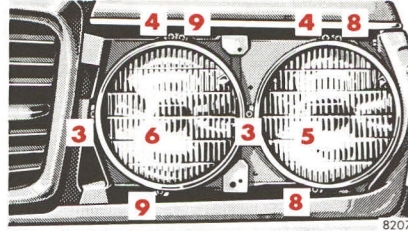

Front Lamps

- 1 Cover
- 2 Securing screws for cover
- 3 Horizontal adjusting screws
- 4 Vertical adjusting screws
- 5 High and low beam sealed-beam unit (Halogen) No. 2:
Loosen clamping screws (8), remove retaining ring and lamp, disconnect plug from socket on lamp.

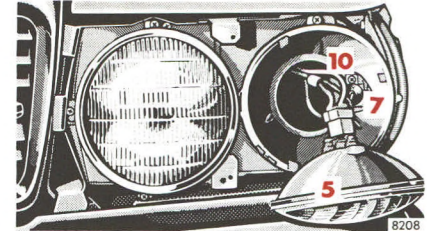

- 6 High beam sealed-beam unit (Halogen) No. 1:
Loosen clamping screws (9), remove retaining ring and lamp, disconnect plug from socket on lamp.
- 7 Side marker lamp (4 W/2 cp bulb):
Remove headlamp (5), loosen clamping screw (10) and detach lamp holder. Depress bulb, turn left and pull out.

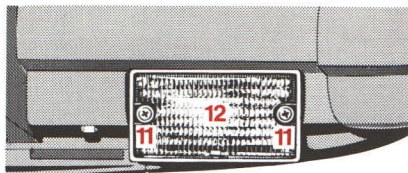

8458

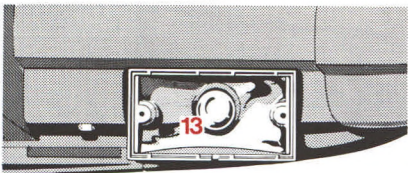

8459

- 13 Bulb for turn signal, parking and standing lamps 21/5 W/32/3 cp:

The lamps are located below the bumper.

Loosen securing screws (11) and remove lens (12).

Depress bulb (13), turn left and pull out. When replacing the lens, it must be ensured that the lug in the lens is at the bottom.

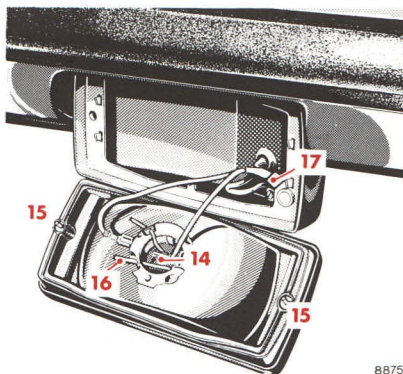

8875

- 14 Bulb for fog lamp (H3):
Loosen securing screws (15) and remove housing. Detach holding spring (16), remove bulb (14) and disconnect plug (17).

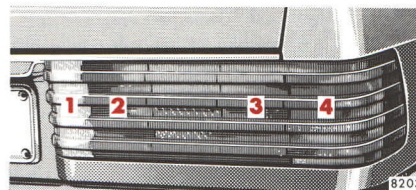

8203

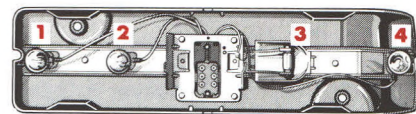

8204

Taillamp Assembly

Remove both knurled nuts in the trunk and pull off bulb carrier. To replace the bulbs, depress, turn left and pull out.

- 1 Backup lamp (21 W/32 cp bulb)
- 2 Stop lamp (21 W/32 cp bulb)
- 3 Tail, parking and standing lamp (10 W bulb)
- 4 Turn signal lamp (21 W/32 cp bulb)
side marker lamp (5 W bulb)

High Mounted Stop Lamp (21 W/32 cp bulb)

To replace the bulb, open trunk lid.
Unscrew four nuts, remove lamp
housing and remove bulb.

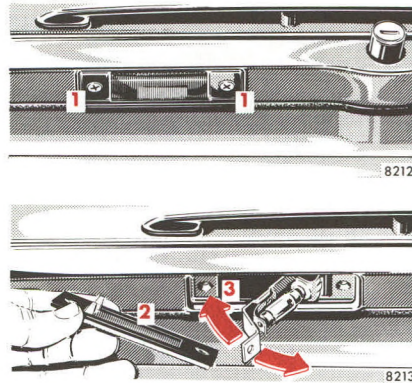

License Plate Lamps (5 W bulb)

Loosen both securing screws (1),
detach lens with gasket (2) and pull
down lamp holder (3) on the L-H
side. Replace the bulb. When
reinstalling the lens, it must be as-
sured that the lug in the lens is on
the L-H side.

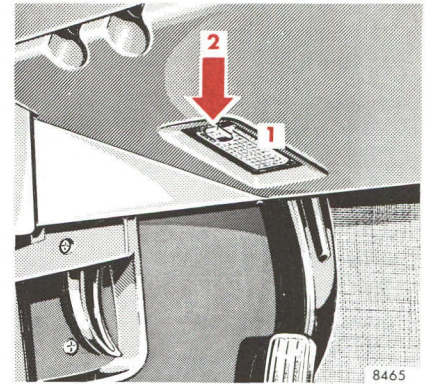

Footwell Lamps (10 W bulb)

Lift off lamp (1) at slot (2) with
screwdriver, replace bulb and
reinsert lamp again.

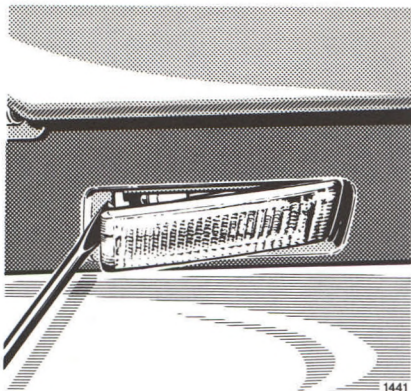

Dome Lamps
(5 W bulb)

To replace the bulb, lift off cover at LH side, and pull out the bulb.

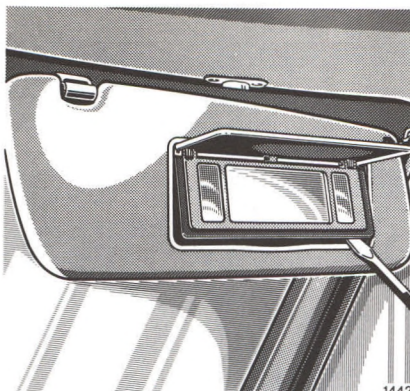

Sun Visor Lamps
(5 W bulb)

To replace a bulb, pry off the cover by inserting a screwdriver in the left and right slots located on the lower edge.

To reinstall the mirror assembly, the cover must be closed.

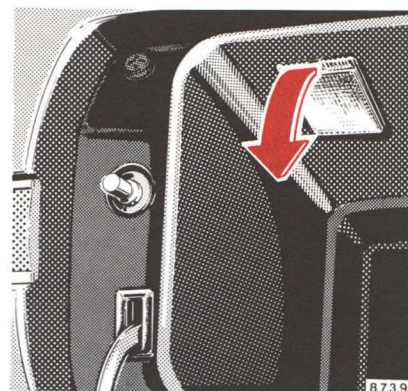

Glove Compartment Lamp
(5 W bulb)

To replace the bulb, pull out lamp.

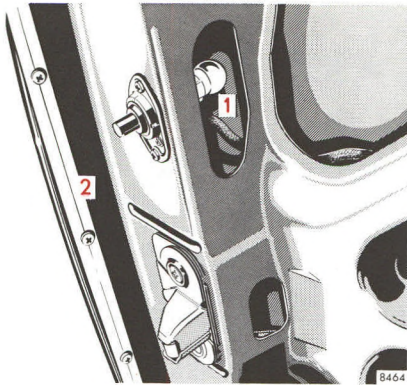

Trunk Lamp (5 W/3 cp bulb)

The trunk lamp (1) is easily accessible when the trunk lid (2) is opened. To replace the bulb, depress, turn counterclockwise and take it out.

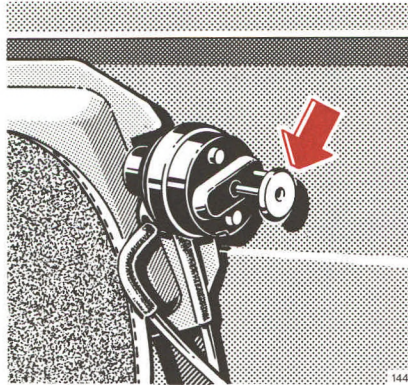

Unlocking of Fuel Filler Flap

If the central locking system does not release the fuel filler flap automatically, access to the actuating vacuum element may be gained through the trunk. Pull down right trunk panel slightly and pull back the knob (arrow) on the vacuum element while opening the filler flap.

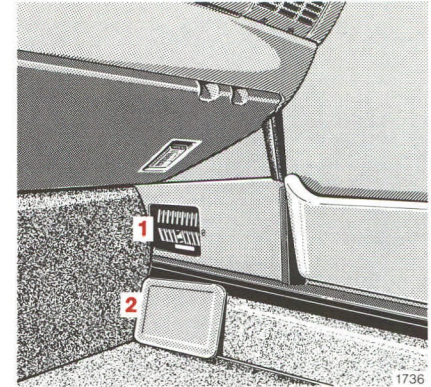

Fuses

The fuse box (1) is located in the R-H side foot well. All equipment protected by fuses is listed by number and letter on a label in the cover (2). The numbers and letters above the fuses correspond to the ones on the label. Fuses must not be repaired or bridged. Always use a new fuse for replacement. Spare fuses (observe amperage and color) are stored with the vehicle tool kit. Diagnose the cause of a short circuit before replacing a blown fuse.

Battery

The battery is located in the trunk.

Check electrolyte level in each cell approximately every four weeks, and more frequently during the summer and in hot climates.

Refill battery only with distilled water. Do not use metal funnels or push through the overfill-protection diaphragms in filler holes.

The battery is completely filled when the water stops draining through the overfill-protection diaphragm.

To check the battery charge with a hydrometer, push its tip through the overfill-protection diaphragm and take an electrolyte sample.

Coat battery terminal clamps with acid-proof grease. Keep battery clean and dry.

The service life of the battery is also dependent on its condition of charge. It must be maintained sufficiently charged for the battery to last an optimum length of time.

Therefore, we recommend that you have the battery charge checked frequently if you use the vehicle mostly for short distance trips, or if it is not used for long periods of time.

Only charge battery with a battery charger when it is disconnected from the vehicle electrical circuit.

Warning!

Battery fluid contains sulfuric acid. Do not allow this fluid to come in contact with eyes, skin, or clothing.

In case it does, immediately flush affected area with water; if necessary seek medical help.

A battery will also produce hydrogen gas, which is flammable and explosive. Keep flames or sparks away from battery, i.e. improper connection of jumper cables, smoking, etc..

While the engine is running the battery terminal clamps must not be loosened or detached as otherwise the alternator and other electronic units would be damaged.

Only tow vehicle with the battery connected.

Spark Plugs

This vehicle is equipped with spark plugs as required for driving in the USA. Should additional information be necessary, your authorized MERCEDES-BENZ dealer will be happy to offer advice.

Tow-starting and Towing the Vehicle

The front towing eye is located on the passenger side below the air-dam and the rear towing eye on the passenger side below the bumper.

Caution!

For tow-starting your vehicle we only recommend using a tow bar. Serious damage can result when using chains, steel ropes or similar devices.

Only tow-start vehicle with the battery cables connected and the key in steering lock position 2.

Warning!

When the engine is not running, the brakes and the steering are without power assistance. Under these circumstances, a much greater effort is necessary to stop or steer the vehicle.

Tow-starting a Vehicle

Shift selector lever to position "N". Turn key to steering lock position 2 and have vehicle towed.

After attaining a towing speed of 30 km/h (18 mph) (with cold transmission) or 50 km/h (30 mph) (with warm transmission), shift selector lever to position "2" to tow-start the engine. Touch the accelerator only when the engine starts running. As soon as the engine has started, quickly return selector lever to "N".

If the engine fails to fire within a few seconds, return the selector lever from "2" to "N" as otherwise the transmission may be damaged.

For another starting attempt bring the car to a full stop first, move selector lever to position "N", wait for a short while and repeat the tow-starting procedure again.

Towing a Vehicle

The vehicle may be towed with all wheels on the ground and the selector lever in position "N" for distances up to 120 km (75 miles) and at a speed not to exceed 50 km/h (30 mph).

To positively avoid a possibility of damage to the transmission, however, we recommend to disconnect the drive shaft at the rear axle drive flange on any towing beyond a short tow to a nearby garage.

Do not tow with sling-type equipment.

Towing with sling-type equipment over bumpy roads will damage radiator and supports.

Use wheel lift or flat bed equipment.

Jump Starting

If the battery is discharged, the engine can be started with jumper cables and the (12 V) battery of another vehicle.

Proceed as follows:

1. Position the vehicle with the charged battery so that the jumper cables will reach, but never let the vehicles touch. Make sure the jumper cables do not have loose or missing insulation.
2. On both vehicles:
 - Turn off engine and all lights and accessories, except hazard flashers or work lights.
 - Apply parking brake and shift selector lever to position "P".
 - Be sure the vent caps are tight and level. Place a damp cloth over the vent caps, making certain it is clear of all moving parts.
3. Clamp one end of the first jumper cable to the positive (+) terminal on the discharged battery and the other end to the positive (+) terminal on the charged battery. Make sure the cable clamps do not touch any other metal parts.
4. Clamp one end of the second jumper cable to the grounded negative (–) terminal of the charged battery and the final connection to a grounded heavy metal bracket in the engine compartment or on the engine of the disabled vehicle. Make sure the cables are not on or near pulleys, fans, or other parts that will move when the engine is started.
5. Start engine of the vehicle with the charged battery and run at high idle. Then start engine of the disabled vehicle in the usual manner.
6. After the engine has started, remove jumper cables by reversing the above installation sequence exactly, starting with the jumper cable connected to a heavy metal bracket in the disabled vehicle's engine compartment. When removing each clamp, make sure that it does not touch any other metal while the other end is still attached.

Important!

A discharged battery can freeze at approx. -10°C ($+14^{\circ}\text{F}$). In that case it must be thawed out before jumper cables are used.

Jumper cable specifications:

- Minimum cable cross-section of 25 mm^2 or approx. 2 AWG
- Maximum length of 3500 mm (11.5 ft).

Warning!

Never lean over batteries while jump starting, you might get burned.

Battery fluid contains sulfuric acid. Do not allow this fluid to come in contact with eyes, skin, or clothing. In case it does, immediately flush affected area with water, and seek medical help.

A battery will also produce hydrogen gas, which is flammable and explosive. Keep flames or sparks away from battery, i.e. improper connection of jumper cables, smoking, etc..

Cleaning and Care of the Vehicle

In operation, your vehicle is subjected to varying external influences which, if gone unchecked, can attack the paintwork as well as the underbody and cause lasting damage.

Such damage is caused not only by extreme and varying climatic conditions, but also by air pollution, road salt, tar, gravel and stone chipping. Grease and oil, fuel, coolant, brake fluid, bird droppings, tree resins, etc. should be removed immediately to avoid paint damage. Frequent washing, however, reduces and/or eliminates the aggressiveness and potency of the above adverse influences.

More frequent washings are necessary to deal with unfavorable conditions; for example, near the ocean, in industrial areas (smoke, exhaust emissions), or during winter operation.

You should check your vehicle from time to time for stone chipping or other damage. Any damage should be repaired as soon as possible to prevent the start of corrosion.

In doing so, do not neglect the underside of the car. A prerequisite for a thorough check is a washing of the underbody followed by a thorough inspection. Damaged areas need to be re-undercoated.

Your vehicle has been treated at the factory with a wax-base rust-roofing in the body cavities which will last for the lifetime of the vehicle. Post-production treatment is neither necessary nor recommended by MERCEDES-BENZ because of the possibility of incompatibility between materials used in the production process and others applied later.

After every engine cleaning you should have the engine compartment re-rustproofed with MB anti-corrosion wax. Before rustproofing, all control linkage bushings have to be lubricated with hydraulic oil (check with your authorized MERCEDES-BENZ dealer for recommended brands).

We have selected car-care products and compiled recommendations which are specially matched to our vehicles and which always reflect the latest technology. You can obtain MB car-care products at your authorized MERCEDES-BENZ dealer.

Scratches, corrosive deposits, corrosion or damage due to negligent or incorrect care cannot always be removed or repair with the car-care products recommended here. In such cases it is best to seek aid at your authorized MERCEDES-BENZ dealer.

The following topics deal with the cleaning and care of your vehicle and give important "how-to" information as well as references to recommended MB car-care products.

Car Washing

Before washing your vehicle, remove insect residues. MB insect remover is recommended. Do not use hot water or wash your car in direct sunlight. Use only a mild car wash detergent, such as MB auto shampoo.

Thoroughly spray the car with a diffused jet of water. Direct only a very weak spray towards the ventilation intake. Use plenty of water and rinse the sponge and chamois frequently.

Rinse with clear water and thoroughly wipe dry with a chamois. Do not allow cleaning agents to dry on the finish.

Never run the vehicle through an automatic car wash with the soft top in use.

If the vehicle has been run through an automatic car wash – in particular one of the older installations – rewipe the recessed sections in the taillamps (designed to prevent soiling) if necessary. No solvents (fuels, thinners etc.) must be used.

In the winter, thoroughly remove all traces of road salt as soon as possible.

When washing the underbody, do not forget to clean the inner sides of the wheels.

Tar Stains

Quickly remove tar stains before they dry and become more difficult to remove. MB tar remover is recommended.

Window Cleaning, Wiper Blades

Use a window cleaning solution on very dirty or oil-stained windows. Clean the wiper blade rubber with a clean cloth and detergent solution. Replace blades at least once or twice a year.

To assist with the removal of accumulated road film on the windshield and improve wiping ability, a cap of MB auto shampoo can be added to the 5 liter container of washer solvent.

Plastic Parts, Headliner and Rubber Parts

Do not use oil or wax on these parts.

Seat Belts

The webbing must not be treated with chemical cleaning agents. Use only clear, lukewarm water and soap. Do not dry the webbing at temperatures above 80° C (176 ° F) or in direct sunlight. Never bleach or re-dye the webbing as this may severely weaken the belts.

Steering Wheel, Selector Lever and Instrument Cluster

Use a gentle dish-washing detergent or mild detergent for delicate fabrics as a washing solution. Wipe with a cloth moistened in lukewarm solution. Do not use scouring agents.

Upholstery

Using aftermarket seat covers or wearing clothing that have the tendency to give off coloring (e.g. when wet, etc.) may cause the upholstery (velour for example) to become permanently discolored. By lining the seats with a proper intermediate cover, contact-discoloration will be prevented.

Leather Upholstery

Wipe leather upholstery with a damp cloth and dry thoroughly or clean with MB leather care. Exercise particular care when cleaning perforated leather as its underside should not become wet.

Paintwork, Painted Body Components

MB-Gloss Preserver should be applied when water drops on the paint surface do not “bead up”; normally in 3–5 months depending on climate and washing detergent used.

MB-Polish should be applied if paint surface shows signs of dirt embedding (i.e. loss of gloss).

MB-Fine Polishing Paste must be used when the paint surface shows signs of excessive fading/chalking due to lack of care, etc..

Do not apply any of these products or wax if your car is parked in the sun or if the hood is still hot.

Use the appropriate MB-Touch-Up Stick for quick and provisional repairs of minor paint damage (i.e. chips from stones, car doors, etc.).

Light Alloy Wheels

If possible, clean wheels once a week with MB- alloy wheel cleaner and sealer. Use an ample supply of water.

Ornamental Moldings

For regular cleaning and care of very dirty chrome-plated parts, use a chrome cleaner.

Soft Top

Stow the soft top in the storage compartment only if the top is completely dry. If the top is kept in the storage compartment for a lengthy period, unfold and air it out with the windows down from time to time.

Remove bird droppings immediately. The organic acid damages the material and causes the top to leak.

In general, regular spraying or cleansing with clear water will do. Wash top only when heavily soiled, not every time the car is washed.

Never run the vehicle through an automatic car wash with the soft top in use.

Caution!

Never use any gasoline, thinner, tar and stain removers or similar organic solvents to clean top or rear window.

Dry cleaning:

Brush top (always from front to rear) with a soft-bristled brush.

Wet cleaning:

Brush the dry top. Wash with a mild detergent and an ample supply of lukewarm water by wiping with a soft-bristled brush or a sponge from front to rear. Then cleanse thoroughly with clear water.

If only parts of the top have been washed, wet the entire top and allow it to air-dry before folding it away into the storage compartment. Wipe the rear window with a cloth soaked with a mild, non-abrasive detergent, rinse, and rub dry. Do not use sharp-edged instruments for the removal of ice and snow.

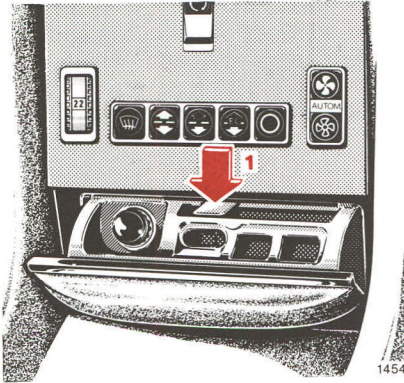

Ashtray

Removal of ashtray:

Pull out ashtray up to the stop.
Depress center locking spring (1)
and remove ashtray.

To install ashtray:

Position ashtray squarely and push
in.

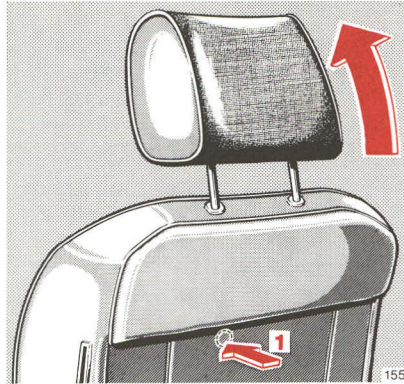

Head Restraints

Removing head restraints:

Move the head restraint slightly for-
ward and pull up to the stop.

Depress release button (1) under
the seatback covering material and
pull head restraint up sharply, hold-
ing it by the left head restraint post
(viewed in driving direction). Then
pull out head restraint completely
with both hands.

The release button (1) is located
below the left head restraint post
on both seats.

Installing head restraints:

Insert the head restraint and push
it down.

Adjust head restraint to the desired
position.

Warning!

**For your protection, drive only
with properly positioned head
restraints.**

**Do not drive the vehicle without
the head restraints. Head
restraints are intended to help
reduce injuries during an
accident.**

For positioning of head restraints
refer to page 31.

Luggage or Ski Racks

We recommend the use of drip rail mounted ski and roof racks. These racks do not require additional supports (suction cups or legs). Such supports may lead to marring of the paint or even denting of the roof if excessive weight is placed on the rack. Your authorized MERCEDES-BENZ dealer can give further advice.

Spare Parts Service

All authorized MERCEDES-BENZ dealers maintain a stock of original spare parts required for maintenance and repair work. In addition, strategically located parts distribution centers provide quick and reliable parts service. More than 200 000 different spare parts, even for older models, are available.

MERCEDES-BENZ original spare parts are subjected to the most stringent quality inspections. Each part has been specifically developed, manufactured or selected for and adapted to MERCEDES-BENZ vehicles.

Therefore, MERCEDES-BENZ original spare parts should be installed.

Technical Data Fuels, Coolants, Lubricants, etc. Consumer Information

Identification Plates	92
Theft Prevention	93
Vehicle Data Cards	94
Warranty Coverage	94
Technical Data	95
Fuels, Coolants, Lubricants, etc.	96
Capacities	96
Engine Oils	98
Brake Fluid	98
Premium Unleaded Gasoline	98
Fuel Requirements	98
Coolants	99
Consumer Information	100

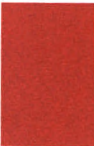

Identification Plates

When ordering spare parts, please specify chassis and engine numbers.

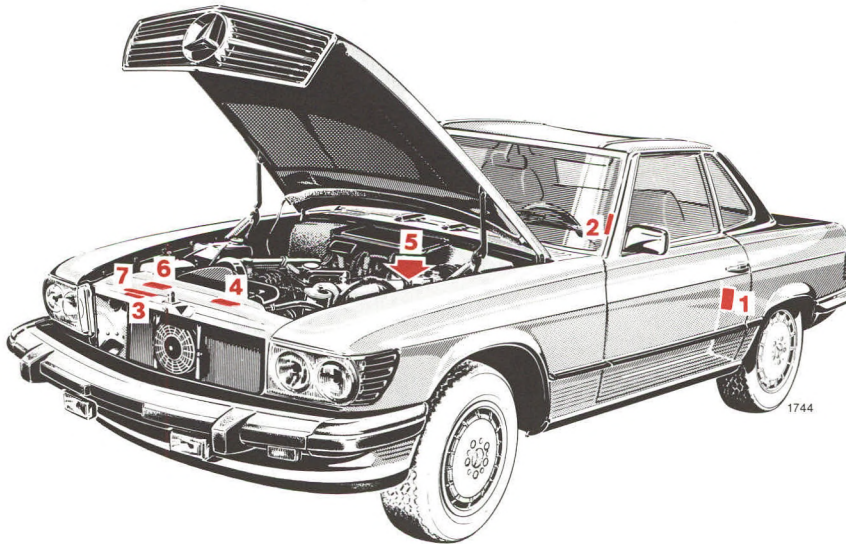

- 1 Certification Tag
(left door pillar)
- 2 Identification Tag
(left window post)
- 3 Vehicle Identification No.
- 4 Body No. and Paintwork No.
- 5 Engine No.
- 6 Information Tag
California version
Vacuum line routing for
emission control system
- 7 Emission Control Tag

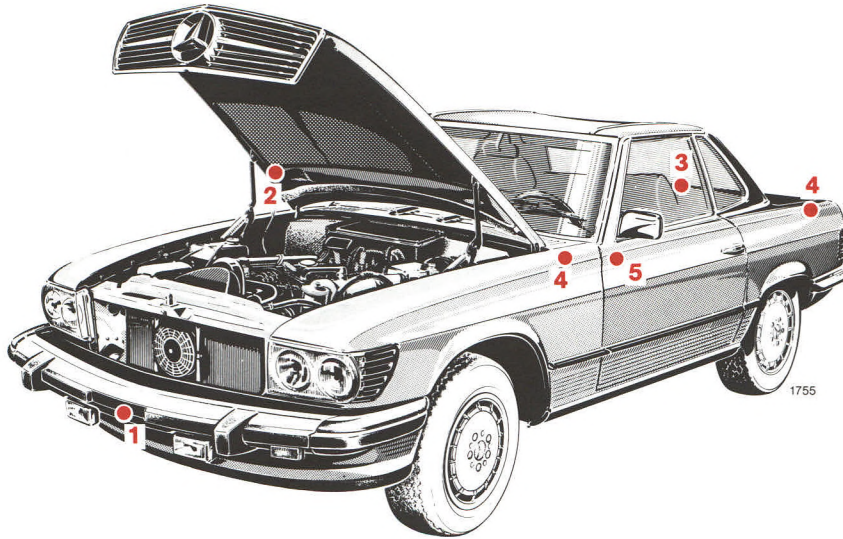

Location of labels

- 1 Bumper front/rear
- 2 Engine hood
- 3 Trunk lid
- 4 All fenders
- 5 All doors

Engine*:
on engine block, left rear

Transmission*:
on transmission, left front

* not shown in illustration

Theft Prevention

This vehicle complies with the Federal Motor Vehicle Theft Prevention Standard (49 CFR Part 541). Engine, transmission and certain body parts (see illustration) are labeled ex factory, the labels show the VIN-number of this vehicle.

Spare parts are similarly labeled ex factory in a different location. The labels show the letter R (for replacement) instead of the VIN-number.

Note:

Do not remove these labels. These labels are intended for parts identification in case of theft. When replacing parts subject to labeling, please make sure that the parts you receive are labeled properly. This is especially important when work is performed outside of the United States.

Vehicle Data Cards

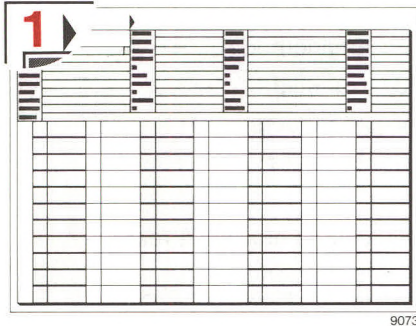

The vehicle data cards bear all the important data relating to your vehicle.

Data card No. 1 bears the key number and should never be left in the vehicle. Submit this card to your authorized MERCEDES-BENZ dealer to request a replacement key in case of loss.

Data card No. 2 has no key number information and should be kept in the Maintenance Booklet where indicated.

Warranty Coverage

Your car is covered under the terms of the “warranties” printed in the Owner’s Service and Warranty Policy Booklet, and your authorized MERCEDES-BENZ dealer will exchange or repair any defective parts in accordance with the terms of the following warranties:

1. New vehicle limited warranty
2. Emission systems warranty
3. Emission performance warranty
4. California emission control systems warranty (State of California only, unless purchased optionally for diesel models).

Loss of Owner’s Service and Warranty Policy

Should you lose your Owner’s Service and Warranty Policy Booklet, have your authorized MERCEDES-BENZ dealer arrange for a replacement. It will be mailed to you.

Technical Data

Model 560 SL (107 048)¹

Engine

Engine type	117
Mode of operation	4-stroke engine, gasoline injection
No. of cylinders	8
Bore	96.50 mm (3.80 in)
Stroke	94.80 mm (3.73 in)
Total piston displacement	5547 cm ³ (338.5 in ³)
Compression ratio	9
Output acc. to SAE J 1349	170 kW/4750 rpm (227 hp/4750 rpm)
Maximum torque acc. to SAE J 1349	380 Nm/3250 rpm (279 ft-lb/3250 rpm)
Firing order	1-5-4-8-6-3-7-2
V-belts:	
Water pump – fan – power steering pump	2 V-belts
Alternator	9.5 x 1100 mm
Air conditioning	9.5 x 990 mm
Air pump	12.5 x 960 mm
	9.5 x 750 mm

Rims – Tires

Rims (forged light alloy rims)	7 J x 15 H2
Wheel offset	25 mm (1.0 in)
Summer tires: Radial-ply tires	205/65 VR 15
Winter tires: Radial-ply tires	205/65 R 15 93 T M+S

Electrical System

Alternator	14 V/70 A
Starter motor	12 V/1.5 kW
Battery	12 V/92 Ah
Spark plugs	see last page

Weights See certification tag

Main Dimensions

Overall vehicle length	4580 mm (180.3 in)
Overall vehicle width	1790 mm (70.5 in)
Overall height	1297 mm (51.1 in)
Wheel base	2455 mm (96.7 in)
Track, front	1465 mm (57.7 in)
Track, rear	1466 mm (57.7 in)

¹ The quoted data apply only to the standard vehicle. See an authorized MERCEDES-BENZ dealer for the corresponding data of all special bodies and special equipment.

Fuels, Coolants, Lubricants, etc. Capacities

Vehicle components and their respective lubricants must match. Therefore use only brands tested and recommended by us. Inquire at your authorized MERCEDES-BENZ dealer.

	Capacity	Fuels, coolants, lubricants, etc.																														
Engine with oil filter	8.0 l (8.5 US qt)	<p>Fuels, coolants, lubricants, etc.</p> <p>Recommended engine oils</p> <table border="1"> <thead> <tr> <th data-bbox="940 460 1090 488">Ambient temp.</th> <th colspan="2" data-bbox="1215 460 1321 488">SAE grades</th> </tr> </thead> <tbody> <tr> <td data-bbox="964 510 987 527">°F</td> <td data-bbox="1056 510 1079 527">°C</td> <td data-bbox="1090 510 1452 779"> </td> </tr> <tr> <td data-bbox="964 555 987 572">+ 86</td> <td data-bbox="1056 555 1079 572">+ 30</td> <td data-bbox="1090 555 1452 572">20W-40, 20W-50, 30¹</td> </tr> <tr> <td data-bbox="964 577 987 594">+ 68</td> <td data-bbox="1056 577 1079 594">+ 20</td> <td data-bbox="1090 577 1452 594">15W-40, 15W-50, 10W-40, 10W-50</td> </tr> <tr> <td data-bbox="964 600 987 617">+ 50</td> <td data-bbox="1056 600 1079 617">+ 10</td> <td data-bbox="1090 600 1452 617">10W-30</td> </tr> <tr> <td data-bbox="964 622 987 639">+ 32</td> <td data-bbox="1056 622 1079 639">0</td> <td data-bbox="1090 622 1452 639">5W-20, 5W-30</td> </tr> <tr> <td data-bbox="964 645 987 661">+ 23</td> <td data-bbox="1056 645 1079 661">- 5</td> <td data-bbox="1090 645 1452 661"></td> </tr> <tr> <td data-bbox="964 667 987 684">+ 14</td> <td data-bbox="1056 667 1079 684">- 10</td> <td data-bbox="1090 667 1452 684"></td> </tr> <tr> <td data-bbox="964 689 987 706">+ 5</td> <td data-bbox="1056 689 1079 706">- 15</td> <td data-bbox="1090 689 1452 706"></td> </tr> <tr> <td data-bbox="964 712 987 729">- 4</td> <td data-bbox="1056 712 1079 729">- 20</td> <td data-bbox="1090 712 1452 729"></td> </tr> </tbody> </table> <p>¹ SAE 40 may be used if ambient temperature constantly exceed +30° C (+86° F).</p>	Ambient temp.	SAE grades		°F	°C		+ 86	+ 30	20W-40, 20W-50, 30 ¹	+ 68	+ 20	15W-40, 15W-50, 10W-40, 10W-50	+ 50	+ 10	10W-30	+ 32	0	5W-20, 5W-30	+ 23	- 5		+ 14	- 10		+ 5	- 15		- 4	- 20	
Ambient temp.	SAE grades																															
°F	°C																															
+ 86	+ 30	20W-40, 20W-50, 30 ¹																														
+ 68	+ 20	15W-40, 15W-50, 10W-40, 10W-50																														
+ 50	+ 10	10W-30																														
+ 32	0	5W-20, 5W-30																														
+ 23	- 5																															
+ 14	- 10																															
+ 5	- 15																															
- 4	- 20																															

	Capacity	Fuels, coolants, lubricants, etc.
Automatic transmission	Initial fill: 8.6 l (9.1 US qt) Fluid change: 7.7 l (8.1 US qt)	MB Automatic transmission fluid
Rear axle	1.3 l (1.4 US qt)	Hypoid gear oil SAE 90 for limited slip differential ¹
Accelerator control linkage		Hydraulic fluid ¹
Power steering	1.2 l (1.3 US qt)	MB Power steering gear oil
Front wheel hubs	approx. 65 g (2.3 oz) each	High temperature roller bearing grease
Grease nipples		Multipurpose or lubrication grease
Door locks		Powdered graphite
Battery terminals		Bosch special grease
Brake reservoir	approximately 0.5 l (0.5 US qt)	MB Brake fluid (DOT4)
Windshield washer system	approximately 5.0 l (5.3 US qt)	MB Windshield washer concentrate
Fuel tank including a reserve of	approximately 85 l (22.5 US gal) approximately 11.5 l (3.0 US gal)	Premium unleaded gasoline: Posted Octane 91 (Average of 96 RON/86 MON)
Cooling system	13.0 l (13.7 US qt)	MB Anticorrosion/antifreeze

¹ Your authorized MERCEDES-BENZ dealer will advise you on recommended brands.



Engine Oils

Engine oils are specifically tested for their suitability in our engines. Therefore, use only engine oils recommended by us. Information on recommended brands is available at your authorized MERCEDES-BENZ dealer.

Brake Fluid

During vehicle operation, the boiling point of the brake fluid is continuously reduced through the absorption of moisture from the atmosphere. Under extremely hard operation conditions, this moisture content can lead to the formation of vapor in the system thus reducing the system's efficiency.

The brake fluid must therefore be replaced annually, preferably in the spring.

It is recommended to use only brake fluid approved by MERCEDES-BENZ. Your authorized MERCEDES-BENZ dealer will provide you with additional information.

Premium Unleaded Gasoline

Caution!

To maintain the engines durability and performance, premium unleaded gasoline must be used. If premium unleaded is not available and low octane fuel is use, follow these precautions:

- have the fuel tank filled only partially with unleaded regular and fill up with premium unleaded as soon as possible,
- avoid full throttle driving and abrupt acceleration,
- do not exceed an engine speed of 2000 rpm, if the vehicle is loaded with a light load such as two persons and no luggage,
- do not exceed $\frac{2}{3}$ of maximum accelerator pedal position, if the vehicle is fully loaded, towing a trailer or operating in mountainous terrain.

Fuel Requirements

Use only Premium unleaded meeting ASTM standard D 439:

The octane number (posted at the pump) must be 91 min. It is an average of both, the Research (R) octane number and the Motor (M) octane number: $[(R+M)/2]$. This is also known as ANTI-KNOCK INDEX.

Unleaded gasoline containing oxygenates such as Ethanol, MTBE, IPA, IBA and TBA can be used provided the ratio of either one of these oxygenates to gasoline does not exceed 10%.

The ratio of Methanol to gasoline must not exceed 3% plus additional cosolvents.

Using mixtures of Ethanol and Methanol is not allowed. MTBE may, however, be added up to 15%. Gasohol, which contains 10% Ethanol and 90% unleaded gasoline, can be used.

These blends must also meet all other fuel requirements such as resistance to spark knock, boiling range, vapor pressure, etc..

Coolants

The engine coolant is a mixture of water and MB anticorrosion/antifreeze, which provides:

- corrosion protection
- freeze protection
- boiling protection (by increasing the boiling point).

The cooling system was filled at the factory with a coolant providing freeze protection to -30°C (-22°F) and corrosion protection. The red area of the temperature gauge is matched to the heating properties of this coolant solution.

The coolant solution must be used year round to provide the necessary corrosion protection and increase in the boilover protection. You should have it replaced every 3 years.

To provide the important corrosion protection, the solution must be at least 33% anticorrosion/antifreeze (equals a freeze protection to -20°C [-4°F]). If you use a solution that is more than 55% anticorrosion/antifreeze (freeze protection

to -45°C [-49°F]), the engine temperature will increase due to the lower heat transfer capability of the solution. Therefore, do not use more than this amount of anticorrosion/antifreeze.

If the coolant level is low, water and MB anticorrosion/antifreeze should be used to bring it up to the proper level (have cooling system checked for signs of leakage).

The water in the cooling system must meet minimum requirements, which are usually satisfied by normal drinking water. If you are not sure about the water quality, consult your authorized MERCEDES-BENZ dealer.

Anticorrosion/antifreeze

Your vehicle contains a number of aluminium parts. The use of aluminium components in motor vehicle engines necessitates that anticorrosion/antifreeze coolant used in such engines be specifically formulated to protect the aluminium parts. (Failure to use such anticorrosion/antifreeze coolant will result in a significantly shortened service life.)

Therefore the following product is strongly recommended for use in your car: MERCEDES-BENZ Anticorrosion/Antifreeze Agent.

Before the start of the winter season (or once a year in the hot southern regions), you should have the anticorrosion/antifreeze concentration checked. The coolant is also regularly checked each time you bring your vehicle to your authorized MERCEDES-BENZ dealer for maintenance service.

Freeze protection	Anticorrosion/antifreeze
-30°C } (-22°F) }	5.75 l (6.1 US qt)
-45°C } (-49°F) }	6.75 l (7.1 US qt)

Consumer Information

This has been prepared as required of all manufacturers of passenger cars under Title 49, Code of U.S. Federal Regulations, Part 575 pursuant to the "National Traffic and Motor Vehicle Safety Act of 1966".

Uniform Tire Quality Grading

Relevant tire grade information on tire flanks.

All passenger car tires must conform to federal safety requirements in addition to these grades.

Treadwear

The treadwear grade is a comparative rating based on the wear rate of the tire when tested under controlled conditions on a specified government test course. For example, a tire graded 150 would wear one and a half (1½) times as well on the government course as a tire graded 100. The relative performance of tires depends upon the actual conditions of their use, however, and may depart significantly from the norm due to variations in driving habits, service practices and differences in road characteristics and climate.

Traction "A", "B", "C"

The traction grades, from highest to lowest, are "A", "B" and "C" and they represent the tire's ability to stop on wet pavement as measured under controlled conditions on specified government test surfaces of asphalt and concrete. A tire marked "C" may have poor traction performance.

Warning!

The traction grade assigned to this tire is based on braking (straight ahead) traction tests and does not include cornering (turning) traction.

Temperature "A", "B", "C"

The temperature grades of "A" (the highest), "B" and "C" representing the tire's resistance to the generation of heat and its ability to dissipate heat when tested under controlled conditions on a specified indoor laboratory test wheel. Sustained high temperature can cause the material of the tire to degenerate and reduce tire life, and excessive temperature can lead to sudden tire failure. The grade "C" corresponds to a level of performance which all passenger car tires must meet under the Federal Motor Vehicle Safety Standard No. 109. Grades "B" and "A" represent higher levels of performance on the laboratory test wheel than the minimum required by law.

Warning!

The temperature grade for this tire is established for a tire that is properly inflated and not overloaded. Excessive speed, underinflation, or excessive loading, either separately or in combination, can cause heat build up and possible tire failure.

Vehicle Stopping Distance

This figure indicates braking performance that can be met or exceeded by the vehicles to which it applies, under different conditions of loading and with partial failures of the braking system. The information presented represents results obtainable by skilled drivers under controlled road and vehicle conditions, and the information may not be correct under other conditions.

Description of the vehicles to which this table applies: **560 SL**

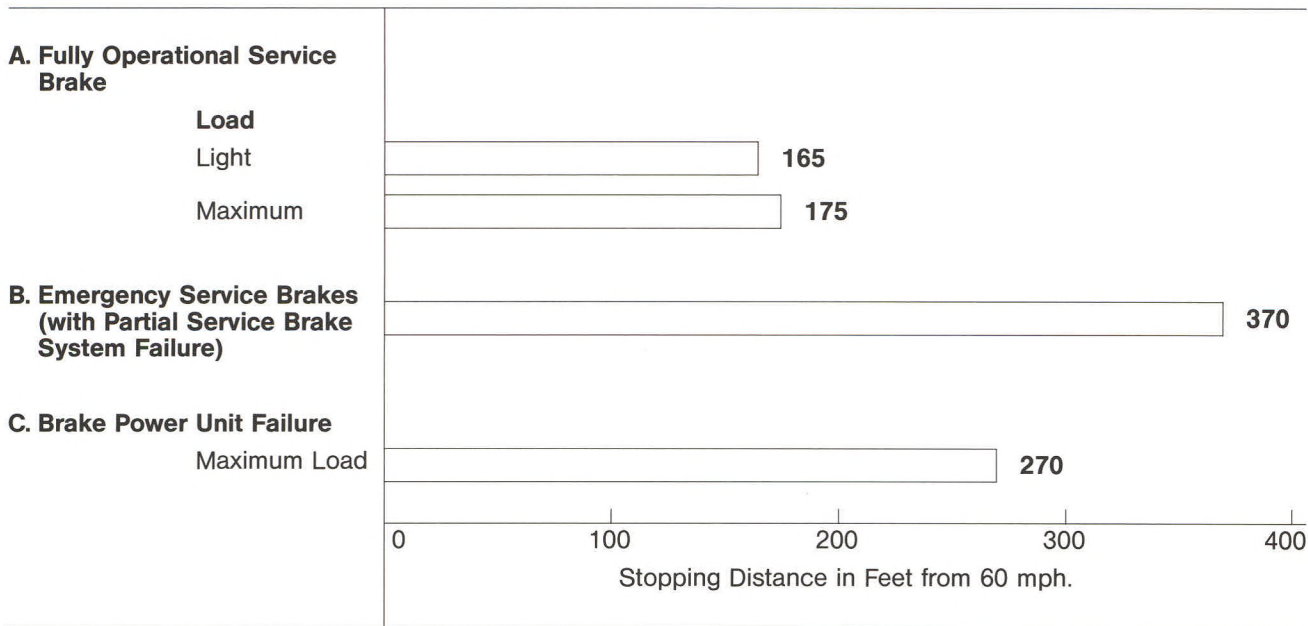



Air bag 35
Alarm system 30
Alloy wheels 86
Antenna 53
Anticorrosion/antifreeze 99
Ashtray 88
Automatic climate control 22
Automatic transmission 56

Battery 81
Body no. 92
Brake fluid 98
Brake pad wear
indicator lamp 61
Brake, parking 56
Brakes 16
Brakes, ABS 60
Brake warning lamp 61
Break-in period 8

Capacities 96
Catalytic converter cautions 14
Central locking system 29
Certification tag 92
Charge indicator lamp 61
Cleaning and care of
the vehicle 84

Combination switch 40
Consumer information 100
Coolant level check 69
Coolants 97, 99
Coolant temperature
gauge 62
Cruise control 59

Deceleration shutoff 64
Doors 28
Driver checks 108
Driving instructions 16

Economical driving
indicator (ECONOMY) 64
Emergency tensioning
retractors 33
Emission control 63
Emission control tag 92
Engine no. 92
Engine oil and
filter change 19
Engine oil consumption 64
Engine oil level check 70
Engine oils 98
Engine starting
and turning off 15
Exterior lamp switch 39

Exterior light failure
indicator lamp 62

Fog lamps 77
Fuel filler flap 80
Fuel requirements 98
Fuel reserve warning
lamp 62
Fuels, coolants,
lubricants, etc. 96
Fuses 80

Gauges 12, 61, 62
Coolant temperature 62
Fuel 12
Oil pressure 61

Headlamps 40, 76
Head restraints 31, 88
Heated seats 32
Hood 68

Identification plates 92
Indicator lamps 61, 62
Brake pad wear 61
Brake warning 61
Charging system 61

Exterior light failure 62
Fuel reserve 62
Low coolant 62
Low engine oil 61
Low washer fluid 62
Instruments and controls 10
Instrument cluster 12

Jack 72
Jump starting 83

Keys 27

Lamps, exterior 39, 76, 77, 78
Fog lamps 77
Headlamps 76
High mounted stop lamp 78
License plate lamps 78
Switch 39
Taillamps 77

Lamps, interior 44, 78, 79, 80
Dome lamps 79
Footwell lamps 78
Glove compartment lamp 79
Sun visor lamps 79
Trunk lamp 80

Lighter 42
Literature 106
Lubricants 96
Luggage or ski racks 89

Maintenance 4, 19

Oil pressure gauge 61
Outside temperature
indicator 63

Paintwork no. 92
Parking 18
Parking brake 56
Premium unleaded
gasoline 97, 98

Radio 49
Rear view mirrors 41
Rear window defroster 43
Restraint systems,
infants and children 37
Roadside assistance 4

Seat belts 33
Warning system 33

Seats 31
Service literature 106
Soft top 45, 87
Spare parts 89
Spare wheel 72
Spark plugs 81
Starting and turning
off engine 15
Steering lock 38
Sun visors 42
Supplemental restraint
system (SRS) 33

Technical data 95
Theft prevention 93
Tire chains 65
Tire inflation pressure 75
Tires 17, 73, 100
Tool kit 72
Towing 82
Transmission, fluid
level check 71
Traveling abroad 64
Turn signals 40

Upholstery, cleaning 86

Vanity mirrors 42
V-belt 95
Vehicle data cards 94
Vehicle identification no. 92

Warranty 4, 94
Wheels 73
Wheels, changing 74
Windows 44
Windshield washer system 40
Winter driving 18, 65

Service Literature

Your authorized MERCEDES-BENZ dealer has trained technicians and original MERCEDES-BENZ parts to service your vehicle properly. For expert advice and quality service, see your authorized MERCEDES-BENZ dealer.

Customers who are interested in ordering service literature for their vehicles are advised to contact MERCEDES-BENZ distributors in the U.S. or Canada at the following addresses, respectively

for U.S.A.: Mercedes-Benz of North America Inc.
One Mercedes Drive
P. O. Box 350
Montvale, New Jersey 07645
Att: Technical Publications
Tel: (201) 573-0600

for Canada: Mercedes-Benz Canada Inc.
849 Eglinton Ave., East
Toronto, Ont., Canada
M 4 G 2 L 5
Att: Technical Publications
Tel: 416-425-3550
Telex: 065-24232

The above companies will be happy to handle any such requests from customers.

We consider this to be the best way to obtain accurate information for your vehicle.

Warning!

To help avoid personal injury, be extremely careful when performing any maintenance work or repairs. Improper or incomplete service may damage the vehicle or its equipment, which may in turn result in personal injury.

If you have any question about carrying out some service, turn to the advice of an authorized MERCEDES-BENZ dealer.

Check Regularly and Before a Long Trip

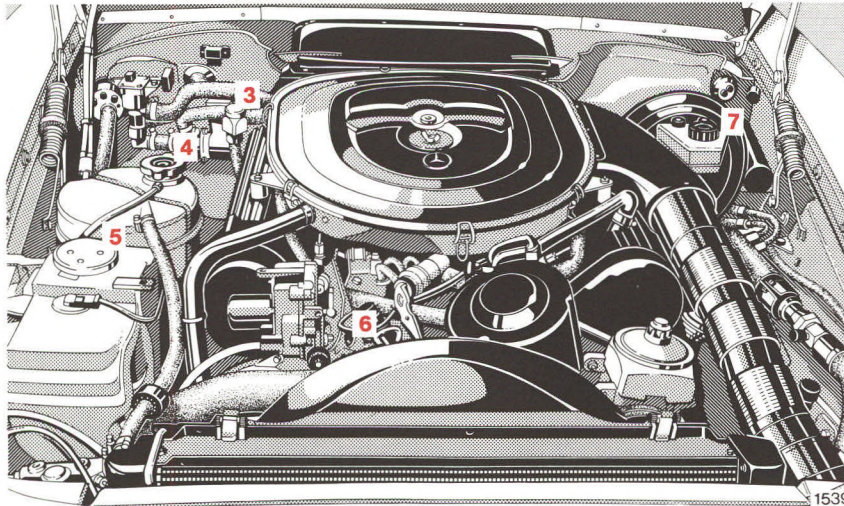
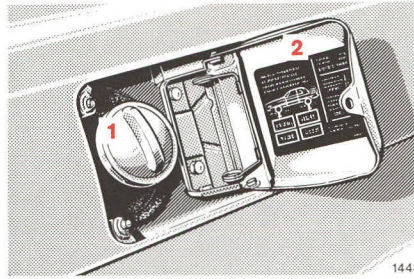
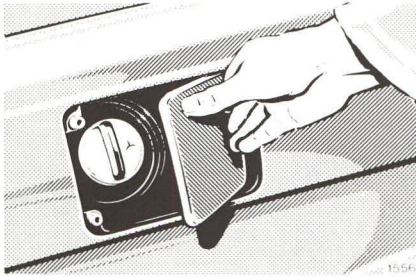

- 1 Fuel Supply:** Turn fuel filler cap to the left and hold on to it until possible pressure in tank has been released, then remove the cap.
- 2 Tire Inflation Pressure:** Check at least every two weeks. For details see page 75.
- 3 Fluid Level in Automatic Transmission:** See page 71.
- 4 Coolant Level:** See page 69.
- 5 Windshield Washer System:** See page 96.
- 6 Engine Oil Level:** See page 70.
- 7 Brake Fluid:** See pages 97 and 98.

Battery: Add distilled or tap water only, see page 81.

Vehicle Lighting: Check function and cleanliness. For replacement of light bulbs, see pages 76, 77 and 78.

What You Should Know at the Gas Station

- **Fuel:** Use premium unleaded gasoline: Posted Octane 91 (Average of 96 RON/86 MON).
Fuel tank capacity approx. 85 l (22.5 US gal), this includes approx. 11.5 l (3.0 US gal) reserve.
Only fill fuel tank until the filler nozzle unit cuts out – do not overfill.
- **Engine Oil:** Engine oil level check, see page 70.
Quantity differential between upper and lower dipstick marking level: 2.0 l (2.1 US qt).
Year-round multigrade oils 10 W-40, 10 W-50, 15 W-40, 15 W-50.
For further information, refer to page 96.
- **Automatic Transmission:** MB Automatic transmission fluid.
For level checks and replenishment, refer to page 71.

- **Tire Pressure:** Cold tires:
For driving up to 180 km/h (110 mph).

Cold tires:

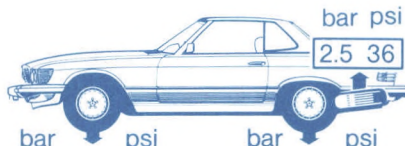

bar psi

bar psi

Summer tires:
Winter tires:

2.0 ¹	29 ¹
2.2	32

2.4 ¹	35 ¹
2.5	36

- **Coolant:** For normal replenishment, use water (potable water quality).

For further information (e.g. anticorrosion/antifreeze), refer to page 99.

- **Bulbs:** High and low beams: Halogen type No. 1 and 2, turn signal, parking and standing lamps, front 21/5 W/32/3 cp, turn signal lamps, rear 21 W/32 cp, tail and standing lamps, rear 10 W, stop lamps 21 W/32 cp, license plate lamps 5 W.
- **Spark Plugs:** Bosch W 9 DC, Beru 14-9 DU, Champion N 9 YC.
Electrode gap: 0.8 mm (0.032 in).

Warm tires:
Pressure may rise by up to +0.5 bar (+7 psi).

Never release any air from a warm tire to offset pressure increase!

¹ For driving above 180 km/h (110 mph) +0.4 bar (+6 psi).

DAIMLER-BENZ AG
Stuttgart-Untertuerkheim
Zentralkundendienst



Mercedes-Benz
service

107 584 22 97

Order No. 6550 5680 13 USA-Ausgabe B/1 1987

