

**350 SL**

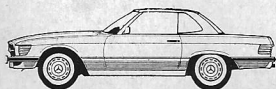

**service**



## **Owner's Manual**

We are pleased to be able to hand over your MERCEDES to you. You have a car in whose construction and production we have taken great pains. For we believe in aiming at quality.

Perhaps you have already had experience with a MERCEDES car, maybe this is your first car from the DAIMLER-BENZ company. In both cases we have one request to make – for your own benefit:

Please do not put this Owner's Manual away without reading it. Even though you have been driving a car for years there might be one or two things in this car which are new to you. And there are certainly one or two hints which will help to avoid annoyance.

Avoided mistakes cannot prompt unpleasant results.

If there should be anything wrong with your car, please come and see us. We built it – for you, and we will attend to it and put it right – for you.

We wish you good motoring.

DAIMLER-BENZ Aktiengesellschaft  
Zentralkundendienst

## Contents

*This Owner's Manual describes optional extras as far as this is required for their operation. As the scope of delivery is determined by the order, the interior trim of your vehicle may deviate from the descriptions to some extent.*

<b>Vehicle Operation</b>		<b>Driving</b>	
Keys, Doors .....	8	Hood .....	26
Master Key and Supplementary Key, Opening, Locking and Unlocking of Doors .....	8	Parking Brake .....	26
Seats .....	9	Regular Inspections .....	27
Front Seat Adjustment, Safety Headrest, Belt .....	9	Starting and Shutting Off the Engine .....	28
Instruments and Controls .....	10	Starting and Shifting Gears .....	29
Instrument Cluster, Speedometer, Tachometer, Indicator Lights .....	12	Safe Driving, Braking .....	31
Steering Lock .....	14	Fuel Consumption, Engine Oil Consumption, Brake Warning Light, Charge Indicator, Temperature Gauge, Oil Pressure Gauge, Tachometer .....	32
Light Switch .....	14	Emission Control .....	33
Combination Switch .....	15	The First 900 Miles .....	33
Heating and Ventilation .....	16	Special Operating Conditions ..	34
Air Conditioning System .....	18	Winter Driving .....	34
Interior Equipment .....	20	Traveling Abroad .....	34
Sun Visor, Courtesy Light, Rear View Mirror, Electric Lighter, Radio .....	20		
Top .....	21		
Coupé Hardtop .....	22		

## Contents

<b>Vehicle Care</b>	<b>Practical Hints</b>	<b>Technical Data, Fuels, Coolants, Lubricants, etc.</b>
MB Maintenance System .....	Ashtray, Vehicle Tool Kit .....	Identification Plates, Vehicle Data Cards .....
36	42	52
Engine Oil Change and Oil Filter Service, Automatic Transmission - Fluid Change and Filter Change .....	Wheels, Tires, Changing Wheels .....	Technical Data .....
36	43	53
Cleaning and Care of the Vehicle .....	Fuels, Coolants, Lubricants, etc. .....	Capacities .....
37	45	55
Jobs related to Care, Care Products .....	Engine Oil Level .....	Fuels, Coolants, Lubricants, etc. .....
38	45	57
Roadster Top .....	Coolant Level .....	Engine Oils, Fuels .....
39	45	Coolants, Antifreezes .....
	Automatic Transmission Fluid Level .....	Literature .....
	46	58
	Electrical System .....	
	47	
	Spark Plugs, Battery .....	
	47	
	Fuses .....	
	47	
	Replacing Bulbs .....	
	48	
	Tow-starting and Towing the Car .....	
	50	



# Vehicle Operation

## Keys Doors

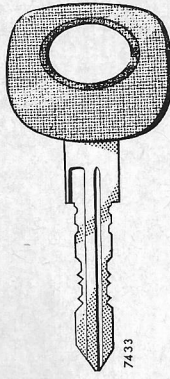
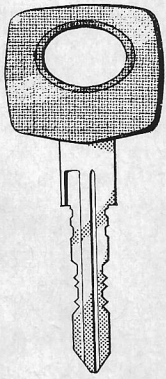

**Master Key** – square headed – fits all locks on the car.

**Supplementary Key** – rounded head – fits only the door locks, the steering lock and the fuel filler cap lock.

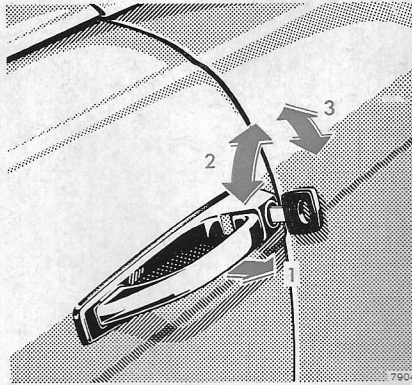

### Opening the Doors

From outside: swing handle outwards (1).

From inside: pull handle in door panel (4).

### Locking and Unlocking of Doors

From the outside: turn key

From the inside: actuate safety catch

2 Unlocking

3 Locking

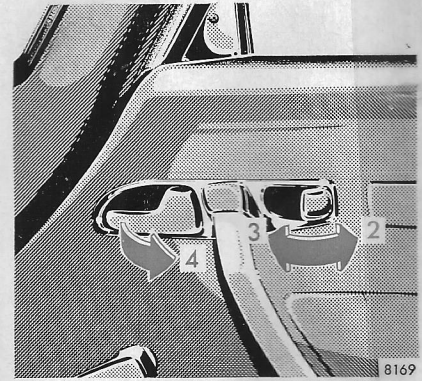

One cannot lock from inside:

- the driver's door if it is open.
- each door if the door lock has not engaged fully.

In this case open the door and shut it again.

8

## Seats

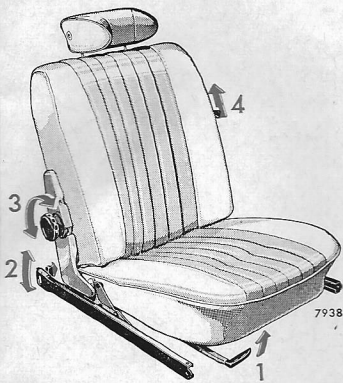

### Front Seat Adjustment

Forward/backward adjustment: lift handle (1), push seat backwards or forwards and allow handle to engage.

Height adjustment of driver's seat (3 positions): pull out rotary handles (2) at the rear ends of the guide rails, turn to desired position and allow to re-engage.

The height of the front passenger seat can be adjusted, if necessary, by relocating the guide rails (2 positions). To do so, unscrew both

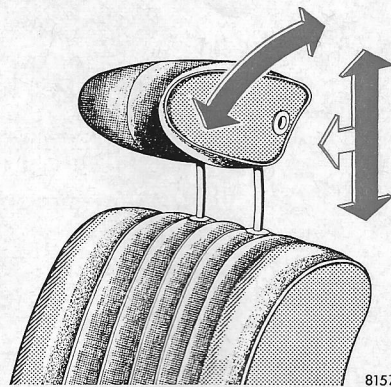

the rear clamping screws and screw in again at the respective bore.

Back rest tilt: turn handwheel (3) back or forth. After disengaging the stop by lifting knob (4), the back rest can be folded forwards.

### Safety Headrest

Adjust headrest to support the back of the head. To adjust the height of the headrest or to remove it, push it slightly forward. The headrest can also be tilted.

### Safety Belt

The vehicle is factory-equipped with safety belts conforming with the American safety equipment standard.

9



## Instruments and Controls

- |   |  |  |
|---|--|--|
| 1 Control levers  | } For side ventilation<br>(left and right) | 12 Hood release lever                                  |
| 2 Movable nozzles   |  | 13 Parking brake pedal <sup>1</sup>                    |
| 3 Parking brake release button<br>(Not applicable for right-hand<br>drive vehicles) |  | 14 Windshield washer button                            |
| 4 Headlight switch  |  | 15 Heater and ventilator                               |
| 5 Combination switch  |  | 16 Blower switch                                       |
| 6 Horn  |  | 17 Temperatur switch,<br>air conditioner               |
| 7 Steering lock and ignition switch   |  | 18 Hazard warning flasher switch                       |
| 8 Radio   |  | 19 Ashtray with cigar lighter                          |
| 9 Swivelling elements of<br>fresh air outlet  |  | 20 Glove compartment handle<br>(push sideways to open) |
| 10 Fresh air control lever  |  | 21 Loudspeaker grille                                  |
| 11 Knob for clock hands<br>(press in to adjust)                                     |  |  |

<sup>1</sup> With right-hand drive vehicles, a hand lever brake has been arranged between the seats.

10

## Instruments and Controls

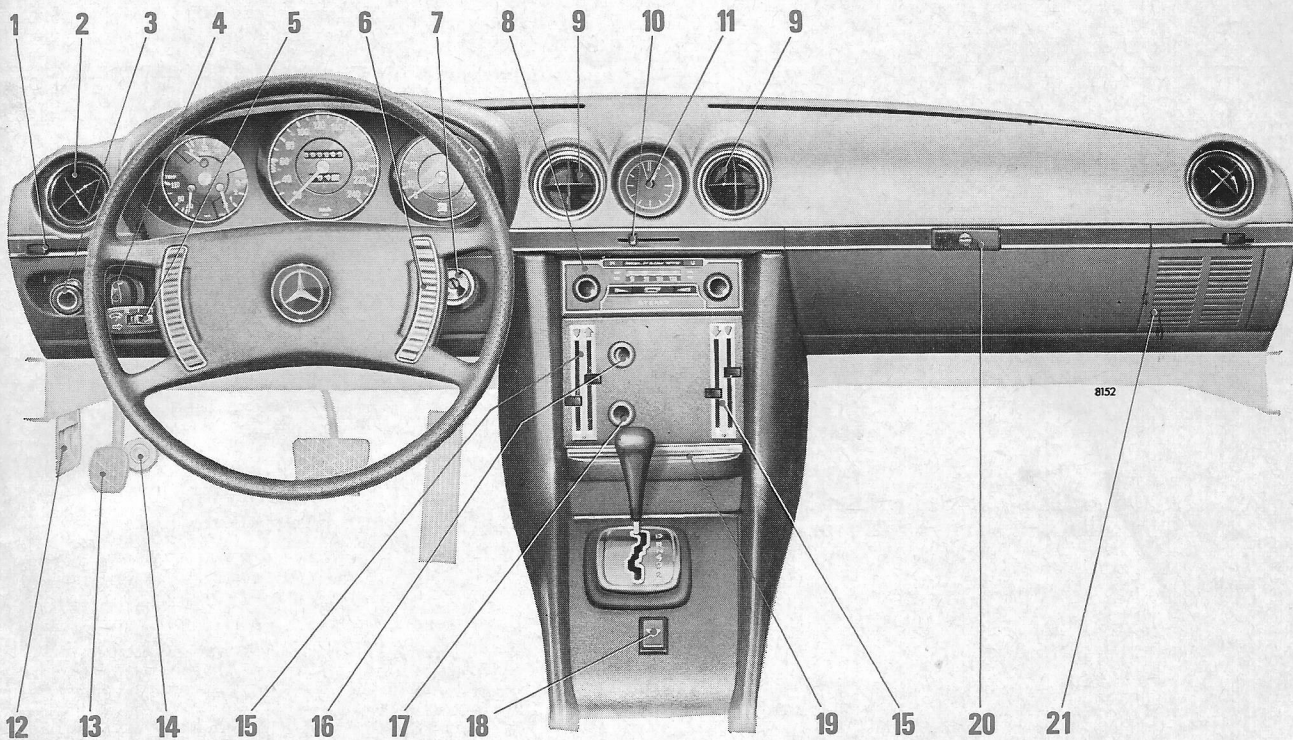

## Instruments and Controls

### Instrument Cluster, Speedometer, Tachometer

- 1 Cooling water temperature gauge ( $^{\circ}$  F), red mark: max. permissible temperature
- 2 Fuel gauge with fuel reserve warning light (Fuel reserve for approximately 22–25 miles/35–40 km)
- 3 Oil pressure gauge (psi)
- 4 Total odometer
- 5 Trip odometer
- 6 Tachometer
- 7 Red mark on tachometer: Maximum permissible engine revolutions, do not exceed a maximum of 5,800 rpm
- 8 Left turn indicator light, green
- 9 Brake warning light, red  
Lights when the parking brake is engaged or the fluid level in the reservoir is low.
- 10 Resetting knob for trip odometer (Push button)
- 11 Dimmer for panel lights, infinitely variable
- 12 Generator indicator light, red  
Lights when the key in the steering lock is switched to driving position "2" and must go out when the engine is idling
- 13 High beam control light, blue  
Lights when the high beam is on
- 14 Right turn indicator light, green

12

## Instruments and Controls

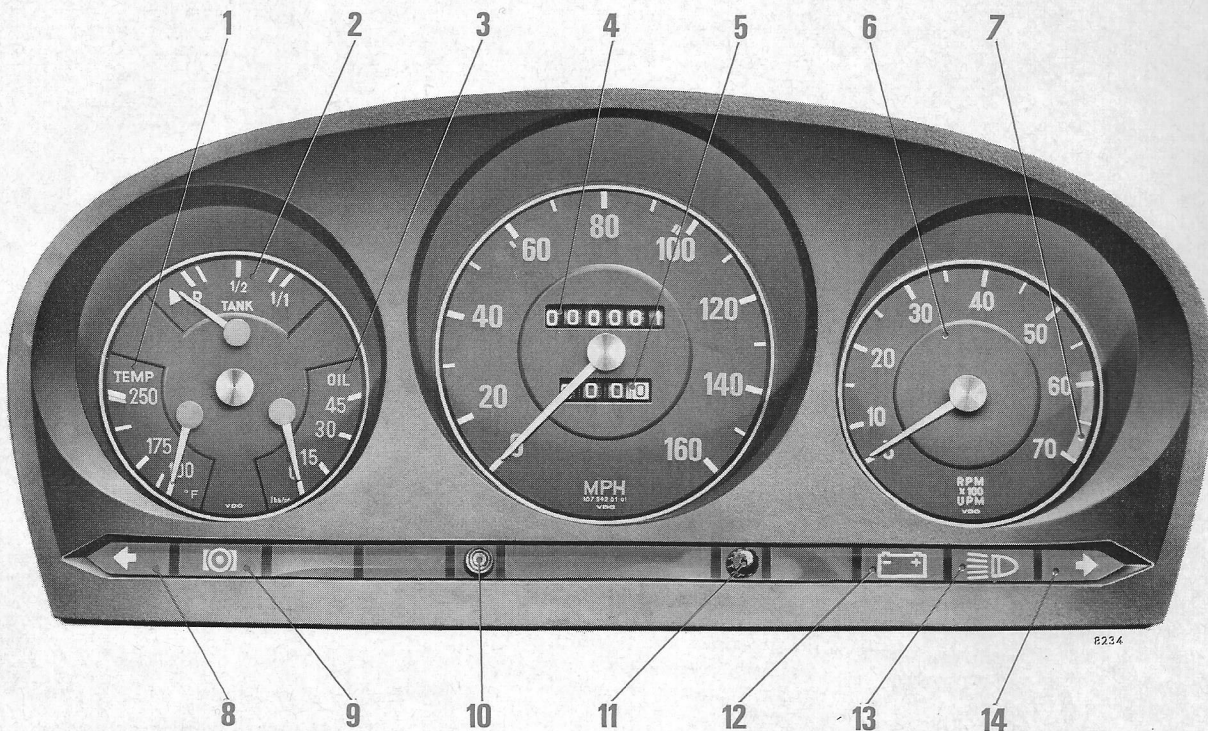

13



## Instruments and Controls

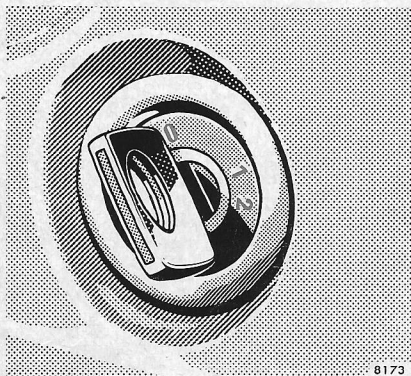

### Steering Lock

- 0 Off position: The steering is locked when the key is withdrawn. The lights can be switched on. The key can be removed only in this position.
- 2 Driving position: Steering is unlocked. (When turning the key clockwise to position "2", slightly move the steering wheel, if required.) The red charging control light comes on. Power supply to standing lights is cut off.

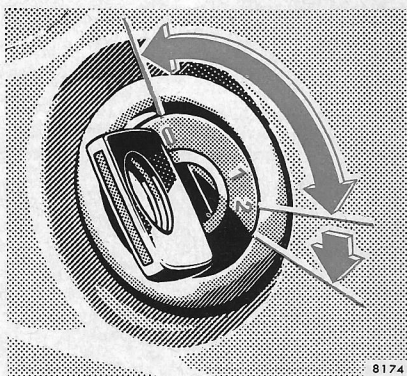

Starting position: Turn key clockwise to the stop. The starter is engaged as long as the key is held up to the stop. Due to the installed starter tripping relay, the key must be returned to position "0" before making another starting attempt.

With the key in position "1", the steering is unlocked. The radio can be switched on. A warning buzzer sounds when the key has been left in the lock and the driver's door is opened.

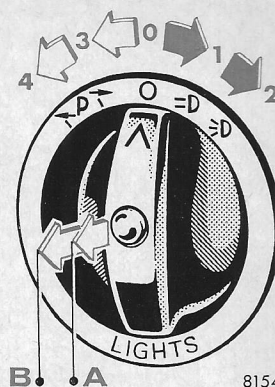

### Light Switch

- 0 Off-position
- 1 Parking lights, side marker lights, tail lights, license plate and instrument panel lights
- 2 Same as position 1 plus high or low beams
- 3 Standing light, right
- 4 Standing light, left
- A As positions 2 plus fog lights
- B Available for an optional extra

14

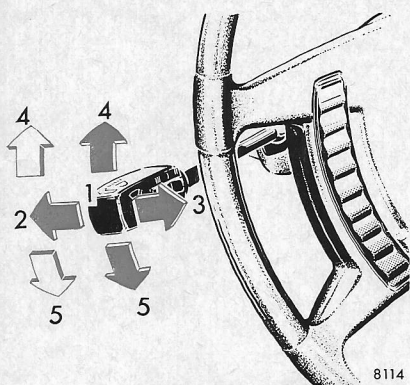

- 1 Low beam (light switch turned clockwise to 2nd notch)
- 2 High beam (light switch turned clockwise to 2nd notch)
- 3 Headlight flasher (high beam available independent from light switch position)
- 4 Turn signals, right
- 5 Turn signals, left for brief signalling, tip switch until resistance is felt for continuous signalling, press switch beyond resistance (engage)

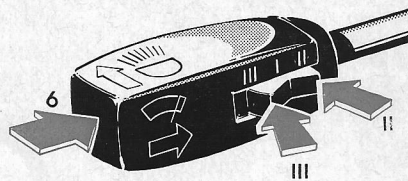

- 6 Windshield wiper (Push button to switch on, push once more to switch off)
  - I Normal wiper speed (center position)
  - II Fast wiper speed (toggle switch pressed to the right)
  - III Intermittent wiping (toggle switch pressed to the left) Wiper performs one cycle every 5 seconds.

### Hints

Use the combination switch to change from low to high beam.

Turn the steering lock key to position "2" to cut off power to standing lights.

The toggle switch automatically returns to position "I" when the windshield wiper is switched off.

Fog lights will only operate together with low beam headlights.

## Instruments and Controls

15

## Heating and Ventilation

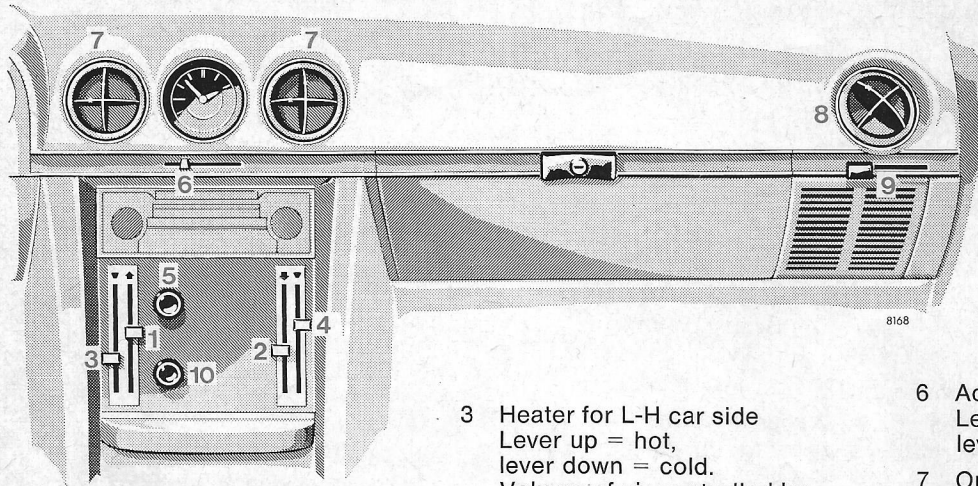

- 1 Air to windshield  
Lever up = open,  
lever down = closed
- 2 Air to leg space  
Lever down = open,  
lever up = closed

- 3 Heater for L-H car side  
Lever up = hot,  
lever down = cold.  
Volume of air controlled by  
levers 1, 2 and 9
- 4 Heater for R-H car side  
Lever up = hot,  
lever down = cold.  
Volume of air controlled by  
levers 1, 2 and 9
- 5 Blower switch (4-speed)  
To switch on, turn right

- 6 Additional fresh air.  
Lever to the left = open,  
lever to the right = closed
- 7 Outlets for additional fresh air.  
Vanes tilttable
- 8 Side ventilation outlets;  
eyeballs swivel
- 9 Lever for side ventilation;  
lever inwards = open,  
lever outwards = closed
- 10 Temperature switch for air  
conditioner

16

The fresh air intake is located in front of the windshield (cowl) and should be kept free of snow.

The fresh air supplied to the interior of the car is infinitely variable with fresh air volume control levers 1, 2 and 9. Levers 3 and 4 control the heating of this air. Additional non-heated fresh air is available by moving lever 6. A continuous draft-free flow of air is supplied through indirect door ventilation even when all the levers are in position "Closed".

Turn on the blower with rotary switch 5 to heat or ventilate the stationary vehicle or if an insufficient volume of air is available during the ride. We recommend using speed 2 for town operation and speed 1 for speedy touring.

In cars with a coupé roof the air is expelled through the vents below the rear window when the side windows are closed. Do not cover up vents (with clothing or similar).

## Heating and Ventilation

Draft-free ventilation and heating:

Open lever 1 for about  $\frac{1}{3}$  of its travel, lever 2 completely and lever 9 for about half of its travel (slightly swing eyeballs 8 outwards). Turn blower switch 5 to low speed.

Defrosting windshield:

Turn levers 1, 2, 3 and 4 upward and blower to full speed with rotary switch 5 (mark DEF). To defrost the side windows, in addition to the above adjustments, move lever 9 inwards and swing eyeballs 8 to point to the side windows.

17



## Air Conditioning System

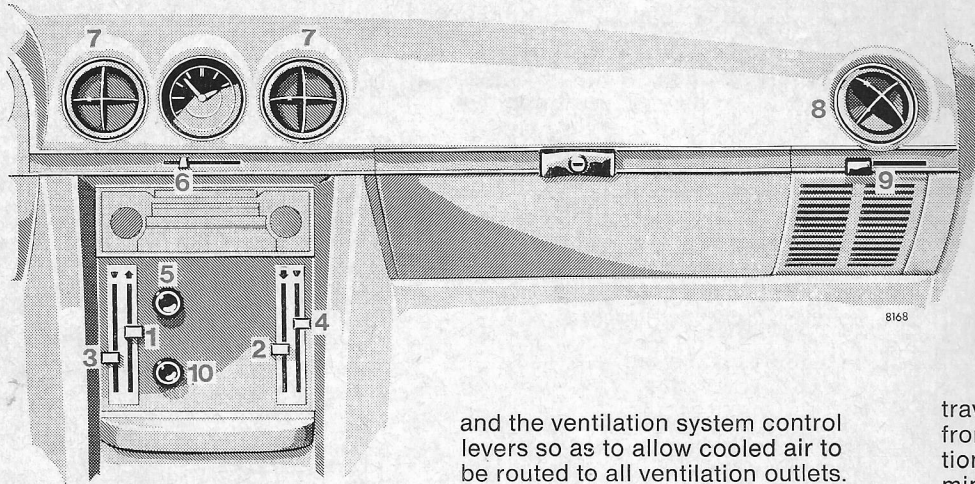

Combined with the ventilation control levers, the air conditioning is designed to bring the temperature of the passenger compartment down.

After engaging temperature switch 10, the air is conducted through an evaporator and thus cooled and simultaneously dehydrated. The air volume is controlled by the blower

and the ventilation system control levers so as to allow cooled air to be routed to all ventilation outlets.

The air conditioner is operational only if the engine is running. High engine speeds correspond to high compressor speeds and thus mean increased cooling effect.

10 Temperature switch. Switch on by turning to the right. The cooling effect is increased infinitely until the switch contacts the stop. After  $\frac{3}{4}$  of the switch

travel, the system changes over from fresh air cooling to circulation cooling ("INSIDE") with a minor proportion of fresh air. An indicator light in the switch comes on while the system is working.

When the temperature switch is engaged, the blower speed is simultaneously cut down. We also recommend the application of a higher blower speed with increasing cooling effect (switch 5).

## Air Conditioning System

### Rapid cooling:

- Fully turn on temperature switch and blower.
- Shift air volume control levers 1, 2, 6 and 9 to position "Open" and heater control levers 3 and 4 to position "Closed".
- Close side windows completely. (Hot air inside can first be evacuated by briefly driving with the side windows down.)

To reduce the cooling effect:  
Rotate blower and temperature switches to the left.

### Windshield fogging on the outside:

The windshield outside may fog during relatively damp weather. In this case, shift downwards air volume control lever 1 to supply less cooled air to the windshield.

Windshield fogging on the inside:  
The air conditioner may be switched on in addition to the heater (temperature switch adjusted to approximately  $\frac{3}{4}$  of maximum efficiency).

The moisture inside the vehicle will then be absorbed by the evaporator of the air conditioning system.

### Important

In order to maintain the air conditioning system in good working order, it is necessary to operate the system for a brief period at least once a month. This includes the seasons when it is normally not in use. To avoid annoying cold air, switch the blower to first speed only.



## Interior Equipment

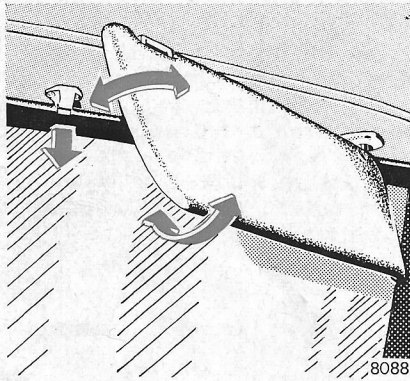

### Sun Visor

Swing sun visor down to protect against sun dazzle. If sun light enters through the side windows, disengage visor from inner mounting and swing aside.

### Interior Lights

The courtesy lights below the instrument panel are switched on as long as the door is open. The glove compartment light can be pulled out and be used as a flashlight. When relocated, it will recharge automatically.

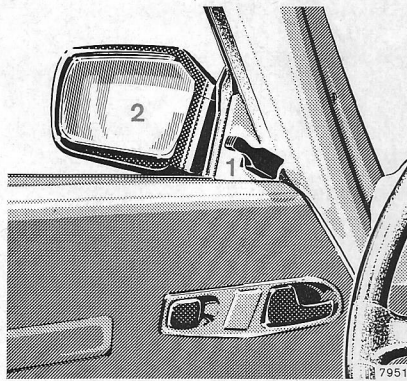

### Rear View Mirrors

Outside: Outside rear view mirror (2) can be randomly adjusted by means of lever (1).

Inside: Can be tilted by means of lever on lower mirror edge. Lever in opposite driving direction = normal position. Lever in driving direction = antidazzle position.

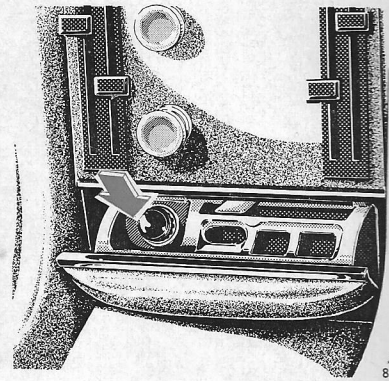

### Lighter

Push the lighter in to heat it. It will pop out as soon as the filament glows. The socket of the heater can also be used to connect other electrical equipment, if it is provided with a suitable plug.

### Radio

The radio can be switched on with the steering lock key being in positions "1" or "2".

20

## Top

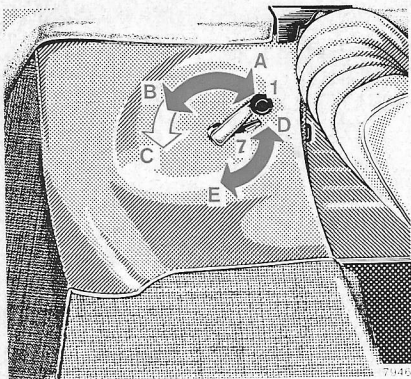

If possible, park vehicle in the shade as continuous exposure to sun rays will harm canvas color and rubber coating.

To lower or raise the folding top or to remove or attach the coupé hardtop, find two locking handles in a bag stowed in the glove compartment. They are used to engage or disengage locks 4 and 8. Put locking handles back into the glove compartment after use.

Lowering the roadster top:  
A wet or frozen canvas top must not be folded.

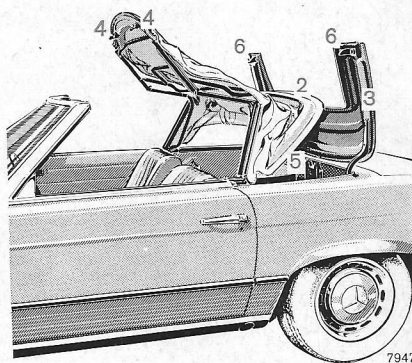

1. Unlock top bow (2) and top storage compartment cover (3) by shifting lever (1) to position C. Lever will automatically return to position B (bow remains unlocked but the top storage compartment cover can be locked). If the top bow cannot be raised in this position, shift lever (7) to position E.
2. Lift up top bow.
3. Open top storage compartment cover (3).

4. Disengage top framework by turning locks (4) inwards. Then detach locking handles.
5. Swing back top framework and slip top into top storage compartment (5). Stow overhanging canvas in the storage compartment.
6. Close top storage compartment cover, making sure that both ends snap in (6).

Raising the roadster top:

1. Move lever (1) to position C and open top storage compartment cover (3).
2. Pull top out of storage compartment and rest top framework against windshield header bar.
3. Tighten top framework by turning locks (4) outwards.
4. Close top storage compartment cover and be sure it engages at both ends.
5. Move downwards top bow until it locks and tighten with lever (1) (position A).

21



## Coupé Hardtop

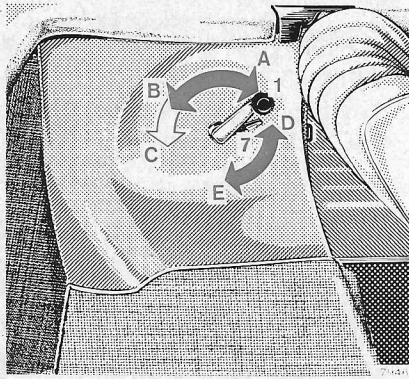

Removal or attachment of the coupé hardtop is best done in a service station, although this can be carried out by 2 persons. The roadster top must be completely dry before it is placed in the storage compartment.

To lower or raise the folding top or to remove or attach the coupé hardtop, find two locking handles in a bag stowed in the glove compartment. They are used to engage or disengage the locks in windshield header bar and behind the doors (8). Put locking handles back into the glove compartment after use.

22

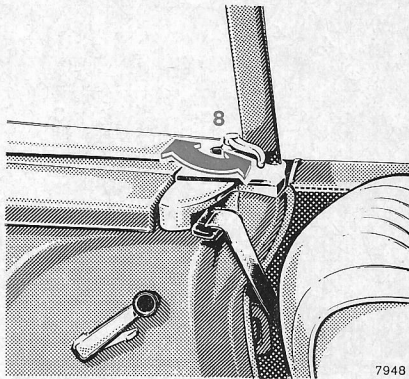

The coupé top is secured at 5 attachment points:

Front = two locks in windshield header bar

Side = one lock behind each door (8)

Rear = top bow lock

If a heated rear window has been installed as optional extra, first disconnect plug and socket in the R-H rear passenger compartment prior to removal of hardtop.

Removal of coupé hardtop:

1. Disengage rear locks with levers (1 and 7). (Lever 1 in position B, lever 7 in position E.)
2. Turn side locks (8) rearwards to the stop with locking handles.
3. Insert locking handles into windshield header bar locks and swivel inwards. Detach locking handles.
4. Cautiously detach coupé hardtop by removing it to the rear.

Attaching coupé hardtop:

1. Shift lever (1) to position B and lever (7) to position D.
2. Carefully position coupé hardtop, simultaneously inserting all locking pins into the respective locks.
3. Insert both the locking handles into the forward locks and swing outwards.
4. Insert locking handles into side locks (8) and swivel forward to the stop.
5. Push lever (1) to position A.

The roadster top may become moldy if it is kept enclosed in the storage compartment for an extended period. We recommend you to have the roadster top removed in a Mercedes-Benz service station if you intend to drive only with the coupé hardtop for a lengthy period.

Should the roadster top, however, be kept in the car, unfold and air it thoroughly (do not expose to the sun) at regular intervals during the wet and cold seasons.

A special container for the storage of roadster tops or coupé hardtops is available from your Mercedes-Benz service station.

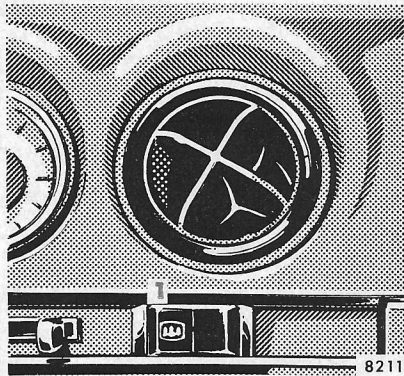

Heated rear window:

Turn key in steering lock to position "2". When the rear window heater is engaged, the white indicator light in the switch (1) comes on. A heavy load is imposed on the battery due to the high power requirement. For this reason, switch off the heated rear window as soon as it is demisted or defrosted. It is cut out automatically after 30 minutes at the latest.

## Coupé Hardtop

# Driving



## Hood

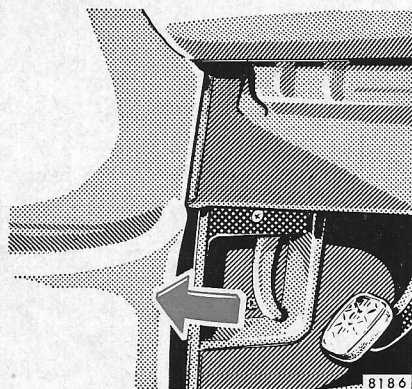

To open, pull handle (below the L-H side of instrument panel) to unlock it. The hood opens to the safety catch stop. Pull lever in radiator grille as indicated by the

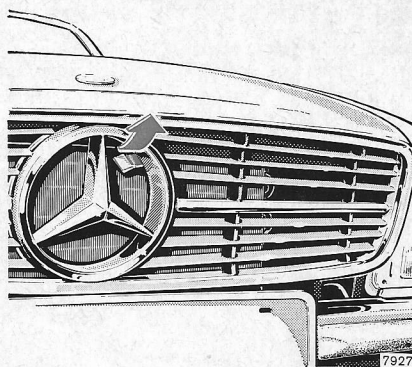

arrow and lift hood (windshield wiper arms must not be folded out). To close, press down hood firmly.

## Parking Brake

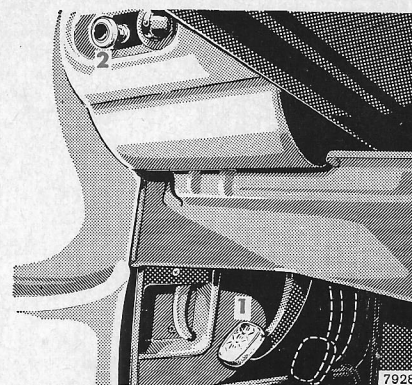

To engage: Depress the parking brake pedal (1) to the farthest possible catch. The parking brake warning light in the instrument cluster comes on when the steering lock key is in position "2".

To release: Pull release button (2) on instrument panel. The parking brake is released at once. There is no gradual release. The parking brake warning light in the instrument cluster must go out.

26

## Have the following items checked regularly and prior to any long Trip

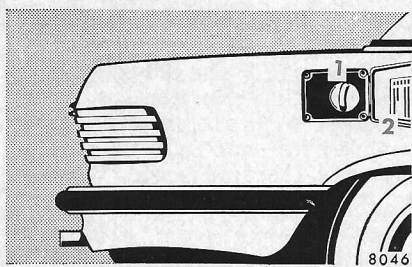

### Fuel Supply 1

Use gasoline, for octane rating see "Fuels, Coolants, Lubricants, etc."

### Tire Pressure 2

Find the tire inflation pressure table in the fuel filler flap. Check at least once a week. For more details see "Wheels, Tires, Changing Wheels".

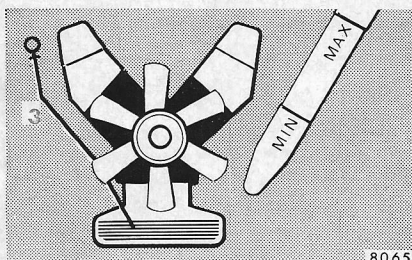

### Engine Oil Level 3

Between the upper and lower dipstick marks. See "Checking Fuels, Coolants, Lubricants, etc." and "Fuels, Coolants, Lubricants, etc."

### Automatic Transmission Fluid Level

### Cooling Water Level 4

Up to about 0.8" - 1.6" (2 - 4 cm) below the cap safety valve seat. See "Checking Fuels, Coolants, Lubricants, etc." and "Fuels, Coolants, Lubricants, etc."

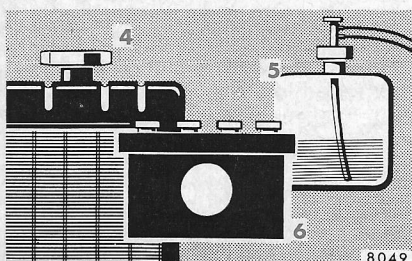

### Windshield Washer 5

Replenish with water mixed with MERCEDES-BENZ windshield washer detergent (container is in the engine compartment). Adhere to the mixing ratio printed on the package.

### Battery 6

Replenish only with distilled water up to the markings in the cells. See "Electrical System".

### Vehicle lighting

Check for function and cleanliness.

27



## Starting and Shutting Off the Engine

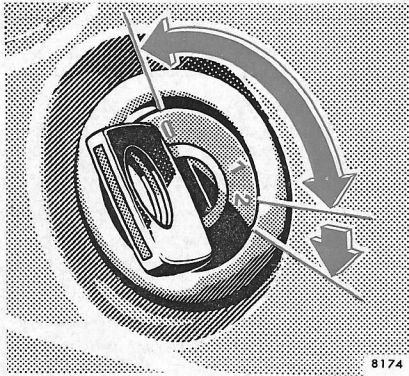

Place the gear selector lever in either "N" or "P" position before starting the engine.

Engage parking brake or service brake.

Turn steering lock key to driving position "2". Red charging control light must come on.

### Cold Engine

Do not accelerate initially. Turn ignition key clockwise to the stop. Slowly accelerate when the engine starts firing. Release ignition key only when the engine runs smoothly.

### Warm Engine

Accelerate at the beginning of the starting procedure.

If the engine has not started after about 10 seconds, discontinue starting and return the ignition key to position "0". Starting can be repeated after a 30 second break.

**After the start**, briefly speed up the engine and then ease off the accelerator to prevent the engine racing.

Observe oil pressure gauge right after starting. Oil pressure in a very cold engine will rise only gradually and some time after starting. Do not speed up engine in the stationary vehicle before pressure is indicated on the oil pressure gauge. The charging control light must go out as soon as the engine is operating.

For starting at low ambient temperatures see "Special Operating Conditions".

### Shutting off

Turn key in steering lock to position "0" and remove only when the vehicle is at a standstill. Move selector lever to position "N" or "P" (automatic transmission).

With very high coolant temperatures (e. g. after hard driving on steep inclines), do not shut off the engine at once but allow to run at slightly increased idle speed for approximately another 1-2 minutes.

## Starting and Shifting Gears

### Selector Lever Positions

The automatic gear shifting process can be adapted to specific operating conditions by means of the selector lever.

"N" Neutral. No power is transmitted from the engine to the rear axle. When the brakes are released, the vehicle can coast freely (to be pushed, towed or towstarted). Do not shift to neutral while driving.

"D" Drive. Normal driving position. All three gears are shifted automatically and consecutively. Position "D" offers optimum driving characteristics in almost all operating conditions.

"S" Slope. Transmission is shifted up to 2nd gear only. Suitable for moderate ascents and descents. As the transmission is shifted up to 2nd gear only, this position permits the utilization of the engine braking effect. If the selector lever is in position "S", upshifting from 1st to 2nd gear will take place later than with the selector lever in position "D". Shifting

### Starting

Shift selector lever to the desired driving position only when the engine is idling. Do not release the brake before moving off. The vehicle may otherwise start creeping when the selector lever is in a driving position.

Shift reverse gear only with the vehicle at halt.

Test service brake after driving off.

Warm the engine smoothly in the lower gear ranges. Do not place full load on the engine until the operating temperature has been reached.

### Hint

If working on a car whilst the engine is idling, engage the parking brake and shift the selector lever to position "P".

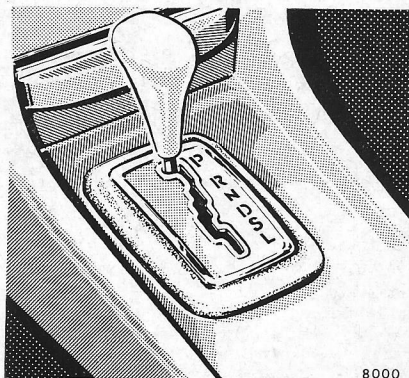

### Shifting Gears

The automatic transmission facilitates and simplifies the handling of the vehicle. The selector lever is shifted to the desired gear range. The individual gears are shifted automatically dependent upon vehicle speed and accelerator position.

#### Accelerator position

Partial throttle = early upshifting  
= normal acceleration

Full throttle = retarded upshifting  
= maximum acceleration



## Starting and Shifting Gears

the selector lever down from "D" to "S" is admissible only below the permissible top speed (two-line marking on speedometer).

"L" Low. Transmission will not shift up. For driving on steep grades and for trailer operation in the mountains. Observe maximum speed (one-line marking on speedometer).

"R" Reverse gear. Shift reverse gear only with the vehicle at halt.

"P" Parking lock. The parking lock is an additional safeguard when parking the vehicle. Engage only when the car is stationary.

### Important:

Bumper to bumper traffic

Shift selector lever to driving position "L" in slow bumper to bumper traffic with frequent stops.

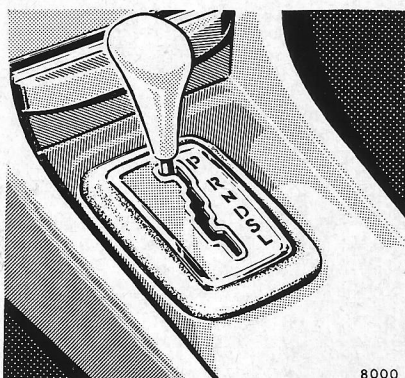

8000

### Maneuvering

To maneuver in restricted area, e. g. when pulling into a parking space, control the car speed by gradually releasing the service brake. Accelerate gently and do not pump the accelerator. To rock a car out of soft ground (mud or snow), alternately shift one forward gear range and the reverse gear at partial throttle.

### Trailer operation

Do not allow the engine speed to drop at uphill gradients to prevent the engine from laboring at low rpm. Depending on the degree of the incline, shift selector lever to positions "S" or "L" in good time.

### Stopping

For brief halts, e. g. at traffic lights, leave the selector lever in a driving position and control vehicle with the brake.

For longer stops with the engine idling, shift selector lever to position "N".

When stopping the car on a slope, do not hold it by means of the accelerator but use the brake. This avoids superfluous heating of the transmission.

## Safe Driving Braking

Always drive in compliance with the "Safety first" principle. The car's comfort can easily tempt you to underestimate the speed at which you are actually traveling. Condition yourself into keeping an eye on the speedometer needle, for high speeds demand increased stopping distance.

On a dry road surface braking generally presents no problems. The more slippery and wet the road surface and the higher the speed, the easier the tires lose their anti-skid properties. A layer of water can form under the tires which seriously impairs steering and braking.

Slow down and brake gently – locked wheels do not shorten stopping distance but are liable to cause loss of steering control.

Do not allow your tires to wear down too far. With less than 3 mm of tread the nonskid properties of the tires are considerably reduced on a wet road.

We recommend to use studded tires on ice or snow. They will cut down stopping distance by roughly half as compared to summer tires. Stopping distance is nevertheless still long in comparison with when the road is dry or wet.

On long and steep descents, ease the load on the brakes by downshifting (shift selector lever to position "S" or "L").

After hard braking it is advisable not to switch off the engine right away but to drive on for some time so the air stream will cool down the brakes faster.

After driving in heavy rain for an extended period without the application of the brakes, the braking effect may be found to be slightly delayed and the brake pedal may have to be depressed harder. In the event of a downpour, keep greater distance between you and the vehicle traveling in front of you.

Once in a while check the effectiveness of the system by fully applying the brakes on an open road (make sure the wheels will not lock). This will also improve the grip of the linings.

## Safe Driving Braking

### Fuel Consumption

Fuel consumption very much depends upon individual driving habits and operating conditions. Extremely low ambient temperatures, operation in city traffic, driving over short distances or in hilly terrain, frequent acceleration and deceleration, etc. will result in increased fuel consumption. It is also increased when optional units (automatic transmission, air conditioner) are installed.

For consumption data see "Technical Data".

### Engine Oil Consumption

Engine oil consumption can only be determined after a certain mileage has been covered. During the break-in period consumption may exceed the average quoted. Frequent high engine speed operation will also cause increased oil consumption.

For average engine oil consumption refer to "Technical Data".

### Brake Warning Light

If the brake warning light in the instrument cluster comes on although the parking brake is released, this indicates a low fluid level in the brake fluid reservoir. Have the brake system checked in a MERCEDES-BENZ service station immediately.

Brake lining wear can be the cause of brake fluid shortage in the reservoir. Only install replacement brake linings approved by us for the respective axles in pairs.

### Charge Indicator

If the charge indicator will not go out after the engine has been started or if it comes on during operation, the alternator is defective and must be repaired in a MERCEDES-BENZ service station at once.

### Oil Pressure Gauge

The oil pressure may drop at idle speed to 7.1 psi (0.5 kp/sq. cm) if the engine is at operating temperature. This will not jeopardize its operational reliability. Pressure must, however, rise immediately upon acceleration.

### Temperature Gauge

On account of the pressurized cooling system the cooling water will boil only at 239° F (115° C). At high ambient temperatures and when the vehicle is driven on mountain roads, the cooling water temperature may rise to 239° F (115° C).

### Tachometer

The red marking on the tachometer is the engine overspeed range; stay there only briefly.

The engine generates maximum torque at 3,000 rpm.

## Safe Driving

### Emission Control (USA Version)

Special devices of the engine and/or adjustments serve to keep the toxic components of the exhaust gases within permissible limits required by law. (Nevertheless, we urgently advise you not to let the engine run in a closed garage, because in such cases the danger of carbon monoxide poisoning still exists.) These devices, of course, will function properly only when adjusted to factory specifications. Any modifications or adjustments on the engine should,

therefore, be carried out only by qualified MERCEDES-BENZ technicians. The devices must not be disconnected or removed nor the adjustments be altered in any way. Moreover, the specified service and maintenance jobs must be carried out regularly according to MERCEDES-BENZ servicing requirements. These service and maintenance jobs particularly require the checking of the carbon monoxide content, the adjustment of the engine idling speed and distributor timing.

## The first 900 Miles

The more cautiously you treat your engine during the break-in period, the more satisfied will you be with its performance later on. Therefore, drive your vehicle during the first 900 miles at varying vehicle and engine speeds.

During this period, avoid heavy loads (full throttle driving) and high rpm (no more than  $\frac{2}{3}$  of maximum permissible speed in each gear) and do not force the engine to labor at low engine speed.

Avoid accelerating to kickdown and do not shift down by hand (downshift for braking), if possible.

After 900 miles (1,500 km) speeds may gradually be increased to the permissible maximum.



## Special Operating Conditions

### Traveling Abroad

Abroad, too, there is a widely-spread MERCEDES-BENZ service network at your disposal. If you travel into areas which are not listed in the index of your service station booklet, you should request pertinent information from your dealer.

### Winter Driving

Have your car winterized in a MERCEDES-BENZ service station before the onset of winter.

- Engine oil change: Have engine refilled with light grade winter oil unless it is filled with multigrade oil recommended by us for year-round use.  
For viscosities and capacities refer to "Fuels, Coolants, Lubricants, etc."
- Antifreeze in the cooling water: Check antifreeze protection periodically.
- Additive in the windshield washer system: Add MB windshield washer solvent to the water in the windshield washer system.

- Test battery: Battery capacity drops with decreasing ambient temperature. A well charged battery ensures that the engine can always be started, even at low ambient temperatures.
- Tires: For the winter season we recommend M+SE tires on all wheels. Recommended top speed with radial ply snow tires – 90 mph (150 km/h).

### Tire Chains

Tire chains are indispensable under unfavorable conditions (deep, freshly fallen snow on inclines).

Retighten newly mounted tire chains after a few miles of driving. Do not exceed permissible maximum speed of 40 mph (70 km/h). On clear roads, remove the chains as soon as practicable. Adhere to the manufacturer's mounting instructions.

### Starting at Low Ambient Temperatures

When traveling short distances and at temperatures below  $-5^{\circ}\text{C}$ , increase engine idle speed before switching off and allow engine to run for a short while until a cooling water temperature of about  $80^{\circ}\text{C}$  is reached in order to keep the spark plugs clean for the next cold start.

Optional electrical heaters for installation in the cooling system are available for areas where extremely low ambient temperatures occur. They are connected to a suitable power source to heat the coolant or keep it warm. See your MERCEDES-BENZ service station on recommended equipment and its installation.

## Vehicle Care

## MERCEDES-BENZ Maintenance System

Like any other technical equipment, the vehicle requires care and maintenance. Scope and frequency of maintenance work depend mainly on operating conditions which, in turn, may vary to a considerable degree.

A maintenance booklet is delivered with your car listing all the maintenance jobs that must be carried out after the following mileages:

- Once after 200 to 600 miles (300–1,000 km).
- Once after 5,000 miles (7,500 km).
- After 10,000 miles (15,000 km) and thereafter every 10,000 miles (15,000 km), but at least once a year.

We should also like to draw your attention to the hints contained in the maintenance booklet covering necessary lubrication services, every 5,000 miles (7,500 km), additional maintenance jobs, every 30,000 miles (45,000 km) and MB individual maintenance as required.

The vehicle must receive the prescribed maintenance and/or lubrication work at the specified intervals as listed in the maintenance booklet. Verification of performance of such maintenance/lubrication work should be recorded in the spaces provided in the maintenance booklet.

The maintenance jobs are described in detail in a manual which you can order from your MERCEDES-BENZ service station.

A small sticker attached to the door post of the driver's door by the service station personnel is to remind you when the next maintenance service or lubrication service is due.



Maintenance service



Lubrication service

### Engine Oil Change and Oil Filter Service

Every 4,500 miles (7,500 km) or at least twice a year (spring and fall). Under heavy duty operating conditions (extremely short distance traffic, dusty conditions) have an oil change every 2,000 to 2,500 miles (3,000–4,000 km) without filter service.

### Automatic Transmission – Fluid Change and Filter Change

To be carried out every 30,000 miles (45,000 km) according to the maintenance booklet.

Under severe operating conditions (e. g. constant city driving, driving in the mountains or with trailer), have the automatic transmission fluid changed every 12,000 to 15,000 miles (20,000–25,000 km) without filter change.

## Cleaning and Care of the Vehicle

In operation, your car is subjected to many external effects which are harmful to body and underside. Besides the often rather inclement and alternating weather conditions, air pollution, thawing salts, tar, and flying gravel come into action.

Particularly unfavorable conditions, as for example in the vicinity of the ocean, in industrial areas (smoke, exhaust emissions), and in winter, may require specific preventive measures.

Have the car regularly inspected for damage caused by thrown up gravel or other mechanical influences.

Damage should be repaired at the earliest possible date, particularly before the onset of the cold season.

We have selected car care products and compiled recommendations which particularly match our vehicles

and which are constantly kept up to date. MB car care products are available at any MERCEDES-BENZ service station.

Their correct application is a prerequisite for the recognition of potential guarantee claims.

Deep scratches, deposits of industrial dust, stains caused by exterior effects and other faults which must be blamed on neglected or incorrect maintenance can sometimes no longer be removed with products for routine care. In such cases it is best to rely on the skill of your MERCEDES-BENZ service station.

The following is a review of the most important car care services and includes information on recommended MB care products as well as hints on important details.

### Insect Removal

#### MB Insect Remover

Apply before washing the car.

### Car Wash

#### Add MB Autoshampoo to the Water

The car should be washed in the shade, not in the sun. Spray it with a dispersed jet of water. Direct only a very weak jet towards the ventilation intake.

Use plenty of water and rinse sponge and chamois frequently.

Rinse with clear water and leather chamois (do not use brushes, cloths, etc.). In winter, thoroughly remove residual thawing salt as fast as possible.

When washing the car underbody, do not fail to clean the inner side of the rims.



## Cleaning and Care of the Vehicle

### Tar Stains

#### MB Tar Remover

Quickly remove tar stains before they dry.

### Windows

#### MB Window Cleaner

Use for heavy and oily soiling of windows. Clean windshield wiper blades with clean cloth and washing solution, replace blades once or twice a year.

### Plastic and Rubber Parts

#### MB Autoshampoo as Washing Solution

Do not use any other solvents, do not oil or wax these parts. Ivory-colored steering wheels are sensitive to colors coming off leather gloves or plastic covers.

### Fabric Upholstery

#### MB Autoshampoo – MB Spot Remover

Brush and vacuum-clean fabric up-

holstery frequently. If badly dirty all over, use dry shampoo.

### MB Autoshampoo

Wipe leather upholstery with a damp cloth and dry thoroughly. Exercise particular care when cleaning perforated leather as its underside must not become wet.

### MB Leather Care

For care and antistatic protection.

### Paintwork

#### MB Polish, MB Gloss Preserver

Do not apply when the car is parked in the sun or when the hood is still hot. The paintwork should be treated with MB polish about every three months. MB polish will also retain the gloss and allow the removal of minor scratches from wooden parts.

MB gloss preserver protects the paintwork and will retain the original shine.

### MB Touch-up Stick or MB Touch-up Paint Spray

For quick and provisional repair of minor paint damage.

### MB Polishing Compound

To polish up heavily dirtied or weathered paintwork or to remedy minor paint damage.

### Garnish Moulding (Chromium-Plated, Aluminium)

#### MB Chrome Care – MB Chrome Cleaner

For regular cleaning and care of heavily soiled chromium-plated parts.

#### MB Chrome Protective Wax MB Chrome Protective Lacquer

For spray preservation in winter.

## Cleaning and Care of the Vehicle

### Roadster Top

(Rubber-coated Canvas)

Stow only a completely dry top in the storage compartment. If the top is kept in the storage compartment for a lengthy period, unfold and air it well with the windows down from time to time.

Remove bird droppings immediately. The organic acid swells the rubber and causes the top to leak.

In general regular spraying or cleansing with clear water will do. Wash top only when heavily soiled, not every time the car is washed.

Caution: Never use any gasoline, thinner, tar and stain removers or similar organic solvents to clean top or rear window.

### Dry cleaning:

Brush top (always from front to rear) with a soft-bristled brush.

### Wet cleaning:

Brush the dry top. Wash with a mild detergent and an ample supply of lukewarm water by wiping the canvas with a soft-bristled brush or a sponge from front to rear. Then cleanse thoroughly with clear water.

If only parts of the top have been washed, wet the entire top at the end of the proceedings and allow the unfolded and tightened top to air-dry. Wipe the rear window with a cloth soaked with a detergent and rub dry. Do not use sharp-edged instruments for the removal of ice and snow.

### Reimpregnation:

Reimpregnation (waterproofing) is required when water droplets are soaked up by the canvas.

Reimpregnation can be carried out in any MERCEDES-BENZ service station where you can also obtain information on suitable impregnation compounds.

# Practical Hints



## Practical Hints

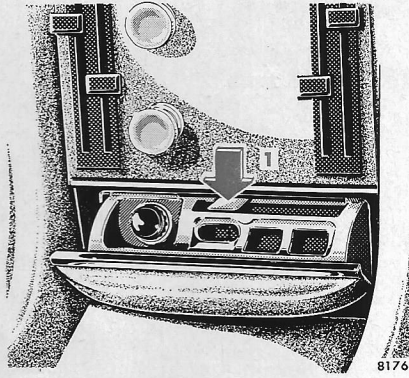

### Ashtray

To remove:  
Pull ashtray out as far as possible.  
Push down the spring (1) in the center and remove ashtray.

To replace:  
Set the ashtray in position accurately and push in.

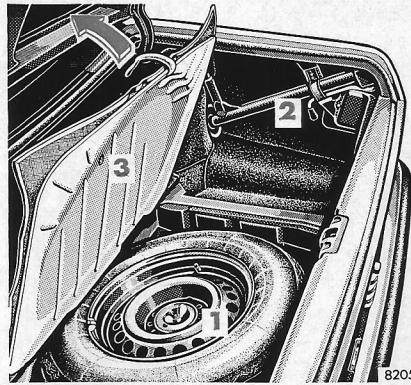

### Vehicle Tool Kit

Spare wheel (1) is stowed in a trough below the folding trunk floor (3). Towing eyes are at the front and rear R-H side.

Jack (2), tools and warning triangle are located in the trunk on the right side.

## Wheels and Tires Changing Wheels

### Tires

See any MERCEDES-BENZ service station for information on tested and recommended tires for summer and winter operation. They will also offer more advice concerning tire service, repair and purchase.

For tires refer to "Technical Data". Mount newly acquired single tires on the front axle. It is advisable to break in new tires over a mileage of approx. 120 miles (200 km) at moderate speeds.

Rotating wheels: the wheels can be rotated according to the degree of wear while retaining the same sense of rotation.

In terms of service life the retention of the same sense of rotation is of paramount importance on studded winter tires.

Note: Thoroughly clean the inner side of the wheels any time you

rotate the wheels or wash vehicle underside. Check the wheel rims for damage at regular intervals. Dented, bent or corroded rims may cause pressure loss and damage to the tire beads. Have wheel rims derusted and repainted whenever the tire is replaced, at the latest, however, every other year.

### Tire Pressure

A table in the tank filler flap lists the tire pressure for radial and winter tires as well as for the varying operating conditions.

Tire pressures quoted for light loads are a minimum and afford optimum driving comfort. Higher tire pressure intended for heavier loads is perfectly permissible for lightly loaded vehicles and is of advantage to the driving characteristics. Suspension will then, however, become somewhat harder.

Tire temperature and pressure increase with the vehicle speed. Tire pressure should therefore only be rectified on cold tires. Correct tire pressure in hot tires only if pressure has dropped below the data listed in the table and the respective operating conditions are taken into consideration.

## Wheels and Tires Changing Wheels

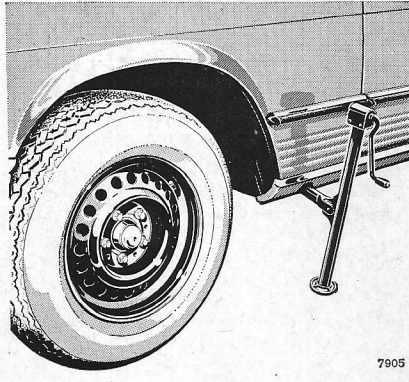
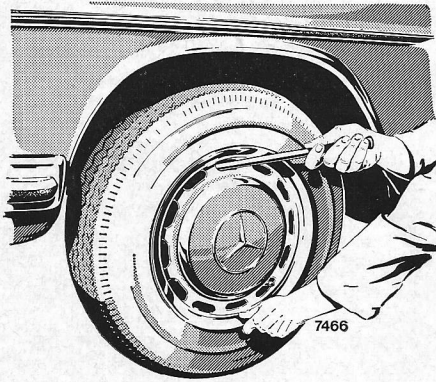

### Changing Wheels

1. Engage parking brake firmly.
2. Move selector lever to position "P".
3. Safeguard vehicle against rolling off by using chocks or similar. Place chocks under both opposite wheels (on downhill side), on a level road on both sides of the opposite front wheel.
4. Insert the combination wrench in one of the trim ring slots and lever off the hub cap.
5. Using the combination wrench, loosen but do not yet remove the wheel bolts.
6. Clean jack supporting tube, if necessary.
7. Insert jack arm into the tube hole up to the stop. Position the jack so that it will always be vertical as seen from the side, even on inclines. Jack up the vehicle until the wheel is clear of the ground.
8. Then back out the wheel bolts. Protect bolt threads from dirt and sand. Remove the wheel.
9. Adjust the jack to allow the wheel to be slipped on without being lifted.
10. Slip on wheel (valve pointing downwards) and press it into the hub disk. Then screw in wheel bolts.
11. Lower car and remove jack. Tighten the five bolts evenly by going around the wheel and tightening every other bolt until all the bolts are tight. Tightening torque is 72.3 ft.lbs. (10 mkp).
12. To install the wheel trim ring, first insert the valve into the center slot between the two trim ring securing clips and press the trim ring against the wheel flange at this point. Then rest the two opposite clips on the rim and seat the trim ring by firmly striking it towards the valve with the flat of the hand.
13. Rectify tire pressure.
14. Have damaged tires repaired immediately.

44

## Checking Fuels, Coolants, Lubricants, etc.

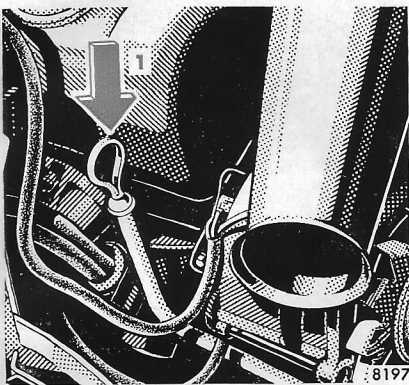

### Engine Oil Level

After the engine has been shut off for a short period of time, check the oil level in the oil pan with the vehicle parked on level ground.

The oil level must be somewhere between the lower and upper dipstick mark (1); do not replenish in excess of the upper mark.

For viscosity and capacity see "Fuels, Coolants, Lubricants, etc."

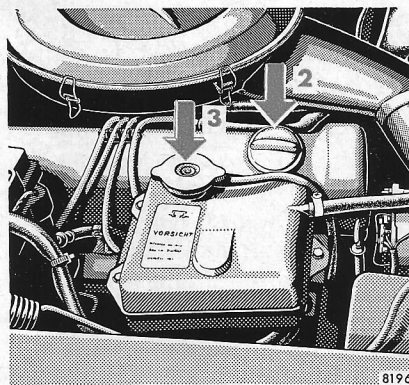

### Coolant Level

Remove the cooling water reservoir cap only if the cooling water temperature is below 194° F (90° C). First turn cap to notch I to release excess pressure.

If the cap is removed immediately, hot water and steam will be ejected. To add cold water to a hot engine, it must be left idling. Hot water may be poured in with the engine cold or warm.

- 1 Dipstick
- 2 Replenishing engine oil
- 3 Replenishing coolant

The correct water level reaches:

- Up to about 1.6" (4 cm) below the cap safety valve seat when the coolant is cold (see instruction plate/decal).
- About 0.8" (2 cm) higher for hot coolant.

The coolant drain plugs are situated on the R-H and L-H engine side and on the radiator bottom.

For antifreeze and corrosion inhibitors see "Fuels, Coolants, Lubricants, etc."

45



## Checking Fuels, Coolants, Lubricants, etc.

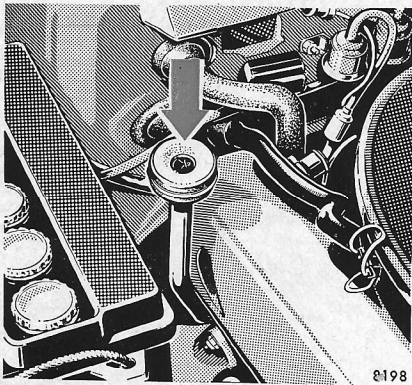

### Fluid Level – Automatic Transmission

If repairs are carried out on the vehicle with the engine running, depress the parking brake pedal to the last possible notch and shift selector lever to position "P".

At regular intervals, check the fluid level of the automatic transmission together with the engine oil level prior to every long trip, at the latest, however, after every 3,000 miles (5,000 km).

To check the fluid level, let the engine idle, engage the parking brake and move the selector lever to position "P". Park car on level ground. Before the check, permit the engine to idle for about 1–2 minutes.

Observe painstaking cleanliness. No woolen fabric must be used to wipe the dipstick (fluff), but select chamois leather. When replenishing fluid through the transmission dip-

stick hole, utilize a fine-mesh strainer. Even the least impurity may cause operational troubles.

The oil level in the transmission is dependent upon the oil temperature. The maximum and minimum oil level marks on the dipstick are applicable references only if the transmission fluid has reached its normal operating temperature of 176° F (80° C). – If, however, the transmission fluid cools down to 68–86° F (20–30° C), which is the normal shop temperature range, then the maximum oil level will be approximately 1.18 in (30 mm) below the minimum mark on the dipstick. We stress this point because an oil change is normally performed when the transmission oil has cooled down to shop-temperature.

The fluid level must not exceed the dipstick maximum mark. Drain or siphon off excess fluid, if required.

46

### Spark plugs

This vehicle is equipped with spark plugs as required for driving in the USA. Should additional information be necessary, your MERCEDES-BENZ dealer will be happy to offer advice.

The spark plugs must not be fouled and should be cleaned at regular intervals: to "clear" fitted plugs from time to time, operate the engine under load conditions and at a high rpm number in the lower gears – as on gradients – but avoid overrevving it. Plugs removed from the engine should be cleaned by means of a rotary plastic-bristle brush and blown out. Do not sand-blast. A special wrench must be used for the removal and installation of spark plugs.

Spark plugs and plug nipples should be checked in a MERCEDES-BENZ service station and in accordance with the instructions contained in the Service Booklet.

### Battery Inspection

Check the battery electrolyte level about every 4 weeks, in summer and in tropical areas more often (depending on conditions).

The electrolyte level must reach the cell markings.

Replenish only distilled water and do not use metal funnels. Lubricate battery terminals with acidproof grease. Keep battery clean and dry.

## Electrical System

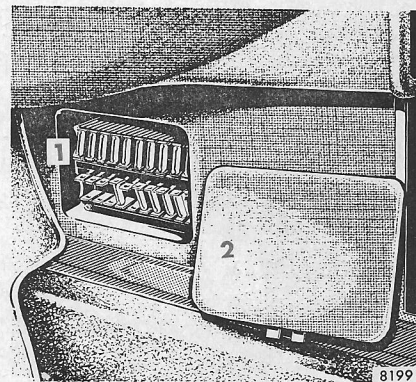

### Fuses

The fuse box (1) is accommodated in the R-H side floor space. A table in the fuse box cover (2) depicts all the protected electrical units. Fuses must not be repaired or bridged. Spare fuses for emergencies are stowed with the tools. Diagnose the cause of a short circuit before replacing a burned-out fuse.

47

## Electrical System

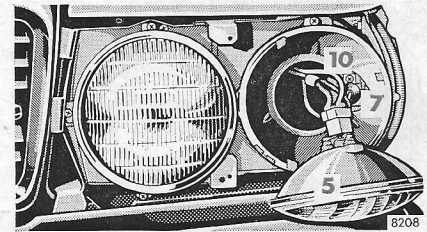
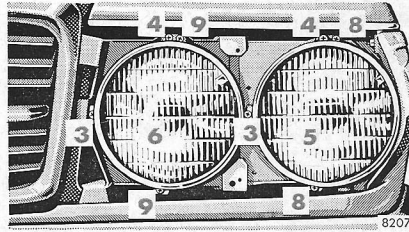
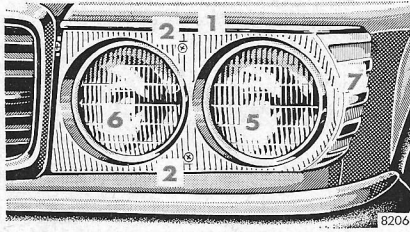

### Replacing Bulbs

To remove, push the bulb in and turn to the left, then lift the bulb out.

To install, grip the bulb with a paper tissue or similar cloth, align the pins on the base of the bulb with the grooves in the bulb socket, push in lightly and turn to the right until the stop is felt.

Install only bulbs of prescribed wattage. Refer to "Technical Data".

### Headlight Aiming

Correct headlight aiming is of paramount importance to the road-worthiness of the car. Check and readjust headlights at regular intervals and invariably when a lamp has been replaced.

### Front Lights

(Sealed Beam Version – USA Specifications)

- 1 Cover
  - 2 Securing screws for cover
  - 3 Horizontal aiming screws
  - 4 Vertical aiming screws
- Loosen securing screws 2 and detach cover 1.
- 5 High and low beam sealed-beam unit (type 2):  
Loosen clamping screws 8, remove retaining ring and unit, disconnect plug and socket on unit.

- 6 High beam sealed-beam unit (type 1):

Loosen clamping screws 9, remove retaining ring and unit, disconnect plug and socket on unit.

- 7 Side marker light:

Remove unit 5, loosen clamping screw 10 and detach lamp holder. Depress bulb, turn left and pull out.

48

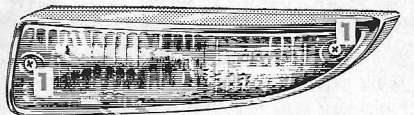

8209

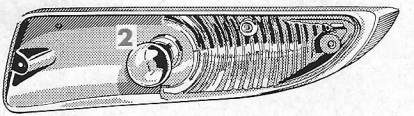

8210

### Front Turn Signal, Clearance and Standing Lights

The lights are located below the bumper.

Loosen securing screws 1 and remove lens.

Depress bulb 2, turn and pull out.

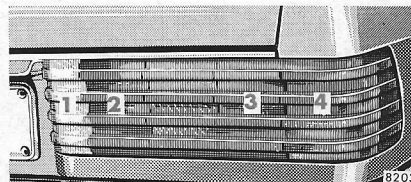

8203

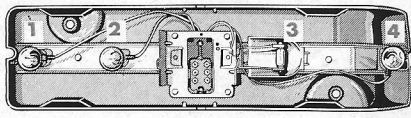

8204

### Tail Light Assembly

Loosen both the knurled nuts in the trunk and detach lamp bracket. To replace the bulbs, depress, turn left and pull out.

- 1 Backup light
- 2 Stop light
- 3 Standing light/tail light
- 4 Turn signal light

## Electrical System

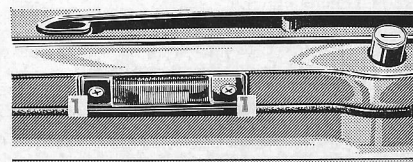

8212

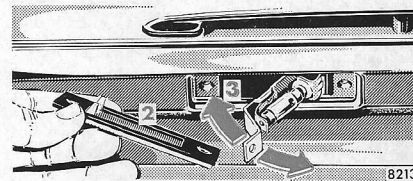

8213

### License Plate Light

Loosen both the securing screws of the light, detach lens with gasket and pull down lamp holder on the L-H side. When replacing the lens, it must be assured that the lug in the lens is on the L-H side.

49



## Tow-Starting and Towing the Vehicle

Towing eyes are situated underneath the R-H front and rear end. Use a towbar or a long rope.

Caution: As long as the engine is not running, the power assistance system is inoperative and substantially greater pedal forces need to be applied for braking; if a power steering is installed, increased effort is also required to steer the car.

### Emergency Engine Start (Tow-Starting) with an Automatic Transmission

Move selector lever to position "N", switch on ignition and have the car towed. After reaching a speed of 30 km/h (with a cold transmission) or 50 km/h (transmission at operating temperature), maintain this

speed for about two minutes to build up sufficient fluid pressure in the transmission.

To start the engine, move selector lever to "L". Only touch the accelerator when the engine is revolving. As soon as the engine has fired, return the selector lever to "N" immediately.

If the engine fails to fire after a few seconds, return the selector lever from "L" to "N" as otherwise the transmission may be damaged. For another attempt, tow car again for a short while with the selector lever in position "N" and then repeat starting procedure.

The same procedure may be used for starting the engine while rolling downhill.

### Towing a Vehicle with Automatic Transmission

The vehicle may be towed over short distances without jeopardizing the transmission if the selector lever is shifted to position "N" and the towing speed does not exceed 30 mph (50 km/h).

For towing the vehicle longer distances or if the transmission is damaged, detach the propeller shaft from the rear axle.

**Technical Data  
Fuels Coolants  
Lubricants etc.**





## Technical Data

<b>Bulbs</b> .....	12 V
High and low beams ..	Sealed beam insert No. 1 and 2
Fog lights .....	Halogen H 3
Turn indicator lights, rear .....	21 W
Stop lights .....	21 W
Backup lights .....	21 W
License plate lights .....	5 W
Tail and standing lights, rear .....	5 W
Turn indicator, parking and standing lights, front	12 W
Side marker lights front/rear .....	4 W/5 W

## Main Dimensions

Overall vehicle length .....	172.1 in. (4,370 mm)
Overall vehicle width .....	70.5 in. (1,790 mm)
Overall height (ready for driving)	
Roadster	51.2 in. (1,300 mm)
Coupé	50.8 in. (1,290 mm)
Wheel base .....	96.9 in. (2,460 mm)
Track, front .....	57.2 in. (1,452 mm)
Track, rear .....	56.7 in. (1,440 mm)

<sup>1</sup> Vehicle loaded with two persons; specifications for 1st gear obtainable on roads affording good grip.

54

## Tires - Rims (Standard)

Rims .....	Rim size 6½ J × 14 H 2
Tires (with tube) .....	205/70 VR 14 (Radial)

**Weights** .....

See certification plate

## Speeds (Top speed)

	mph (km/h)
"L" Low .....	60 (97)
"S" Slope .....	96 (154)
"D" Drive .....	124 (200)

## Gradeability <sup>1</sup>

	1 in. (%)
"L" Low .....	2.33 (43)
"S" Slope .....	2.33 (43)
"D" Drive .....	3.13 (32)

air: 28 front  
30 rear

## Fuels, Coolants, Lubricants, etc., Capacities

	Capacity	Fuels, coolants, lubricants, etc.
Power steering	3.0/2.5 US/Imp. pts. (1.4 l)	Automatic transmission fluid (ATF) Type A Suffix A (if not available use Dexron)
Automatic transmission	Initial fill: 18.8/15.7 US/Imp. pts. (8.9 l) Fluid change: 16.7/13.9 US/Imp. pts. (7.9 l)	Specifically tested and recommended automatic transmission fluid (ATF) according to Dexron
Rear axle	3.0/2.5 US/Imp. pts. (1.4 l)	Hypoid gear oil SAE 90. With limited slip rear axle special hypoid oil
Front wheel hubs	2.3-2.8 oz. ea. (65-80 gr. ea.)	Antifriction bearing grease
Brake and clutch reservoir	1.1/0.9 US/Imp. pts. (0.5 l)	Brake fluid
Fuel tank	23.8/19.8 US/Imp. gals. (90 l)	Gasoline with a minimum RON of 91. Lead-free gasoline may also be used
Cooling system	31.7/26.4 US/Imp. pts. (15.0 l)	Treated water (2.5-5 cu. cm of treating agent per liter)
Grease nipples		Lubrication greases
Door locks		Special greases
Ignition distributor (breaker rubbing block) Battery terminals		Bosch special greases
Windshield washer system	approx. 3.2/2.6 US/Imp. pts. (1.5 l)	Water plus MB windshield detergent

56

## Fuels Coolants Lubricants etc., Capacities

Vehicle components and their respective lubricants must match.

Therefore use only brands tested and recommended by us.

Enquire at your MERCEDES-BENZ service station.

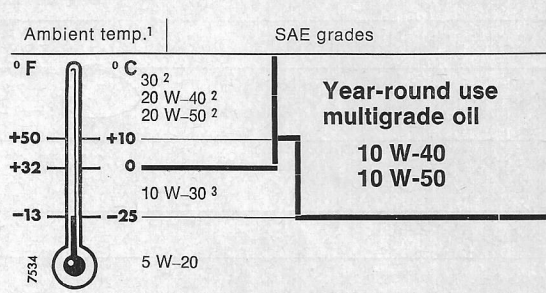
	Capacity	Fuels, coolants, lubricants, etc.
Crankcase	max. 15.9/13.2 US/Imp. pts. (7.5 l) min. 11.6/9.7 US/Imp. pts. (5.5 l)	<p>Recommended engine oil</p>  <p>Ambient temp.<sup>1</sup>   SAE grades</p> <p>° F   ° C</p> <p>30<sup>2</sup> 20 W-40<sup>2</sup> 20 W-50<sup>2</sup></p> <p>+50   +10</p> <p>+32   0</p> <p>-13   -25</p> <p>73/4   5 W-20</p> <p><b>Year-round use multigrade oil</b></p> <p><b>10 W-40</b> <b>10 W-50</b></p> <p><sup>1</sup> SAE 40 may be used if ambient temperatures constantly exceed +86° F (+30° C). <sup>2</sup> Use in temperate zones such as Central Europe as of April until October. <sup>3</sup> Use in temperate zones such as Central Europe as of October until April.</p>
Oil filter	1.6/1.3 US/Imp. pts. (0.75 l)	
Oil cooler	0.9/0.7 US/Imp. pts. (0.5 l)	

55

## Fuels Coolants Lubricants etc.

### Engine Oils

Engine oils are specifically tested for their suitability in our engines. Therefore, use only engine oils recommended by us. Information on recommended brands is available at any MERCEDES-BENZ service station.

A new or reconditioned engine is filled with an initial operation oil in the factory or in a MERCEDES-BENZ service station. This oil is specially developed for the specific operating conditions during the first 180-600 miles (300-1,000 km).

A recommended engine oil may be used for topping up if the oil level drops to the dipstick minimum mark prior to the first service (180-600 miles = 300-1,000 km).

### Fuels

For ping-free engine operation gasoline with a minimum research octane rating (RON) of 91 must be used. Lead-free gasoline may also be used.

### Coolants

**Cooling water**  
Use clean water with low lime content, if possible, or, in case of necessity, thoroughly filtered river water.

The year-round factory-fill coolant is a mixture of an anti-corrosive additive solution and a permanent antifreeze up to -22° F/-30° C.

Formation of scale and corrosion which will lower the efficiency of the system and may even harm it is thus no longer possible.

To treat the cooling water, use no more than ¼-½ % (2.5-5 cu. cm/ltr) of approved corrosion inhibitor. If cooling water leaks from the system, replenish the missing quantity with water plus corrosion inhibitor. For normal topping up (loss due to evaporation of water) plain water will do.

### Antifreeze

The cooling water mixed with antifreeze may remain in the engine all year round. The efficiency of the coolant and antifreeze mixture should be checked several times during of cold weather.

Information on approved corrosion inhibitors and antifreezes can be obtained at any MERCEDES-BENZ service station.

Protection up to	Antifreeze
14° F (-10° C)	6.3/5.3 US/Imp. pts. (3.0 l)
-4° F (-20° C)	10.5/8.8 US/Imp. pts. (5.0 l)
-22° F (-30° C)	14.3/12.0 US/Imp. pts. (6.75 l)
-40° F (-40° C)	16.4/13.5 US/Imp. pts. (7.75 l)

57



## Literature

The following publications are available from your  
MERCEDES-BENZ service station:

- MERCEDES-BENZ Service Station Index  
FEDERAL REPUBLIC OF GERMANY WITH WEST BERLIN  
EUROPE  
AFRICA, AMERICA, ASIA, AUSTRALIA
- Service Manual (cover charge levied)
- Maintenance Booklet – Replacement
- Wiring Diagram

**DB-No. 107 584 17 96**

**Printed in Germany**

We reserve the right to modify the technical details of the vehicle as  
given in the data and illustrations of this Owner's Manual (s.e.e.o.).  
ZKD IX. 71. 5. Ru.

58

107 584 17 96

6500 4614

350 SL · USA-Ausgabe H

Daimler-Benz AG Stuttgart-Untertuerkheim  
Zentralkundendienst