

05-220 Removal and installation of camshafts

Timing with 2 mm valve stroke

Version		all	Exceptions		
			(USA) California 1974	(USA) Federal 1973 and 1974	(J) (USA) 1981
Camshaft code ¹⁾	Exhaust	24, 57, 71, 78	24	30, 95	78
	Intake	25, 67, 74	25, 74	33, 91	74
Intake valve	Opens after TDC	7°		11°	7°
	Closes after BDC	21°		15°	21°
Exhaust valve	Opens before BDC	30°		22°	34°
	Closes before TDC	12°		14°	16°

¹⁾ Camshaft codes are stamped on rear end of camshaft.



Valve clearance	Cold engine (approx. 20 °C)	Warm engine (60 °C ± 15 °C)
Intake	0.10 ¹⁾	0.15 ¹⁾
Exhaust	0.25	0.30





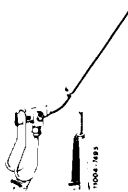

¹⁾ 0.05 mm more for consistent outside temperatures below -20 °C.

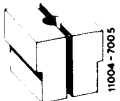
Data

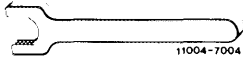
Permissible runout of center bearing journal and camshaft sprocket seat when camshaft turns on outer bearing journals	0.025
Scleroscope hardness of cams	68-82

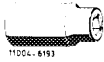
Special tools

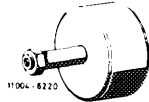
Depressor for valve spring		110 589 04 61 00
Rigid chain tensioner		110 589 03 31 00
Chain tensioner holder		110 589 02 31 00

Camshaft holding wrench		116 589 01 01 00
Valve adjusting wrench 17 mm		110 589 01 01 00
Wrench socket 27 mm, 1/2" square to turn engine		001 589 65 09 00
Wrench socket 10 mm 1/2" square, 140 mm long		000 589 05 07 00
Impact extractor for bearing pin (basic unit)		116 589 20 33 00
M 6 x 50 bolt for impact extractor		116 589 01 34 00
Tightening torques		Nm
Cylinder head bolts M 12 x 1.5		100
Bolts M 8 camshaft housing to cylinder head and crankcase		25
Necked-down screw for camshaft sprockets		80
Chain tensioner oil jet		25
Valve adjusting screw		20–40
Cylinder head cover bolts and capped nuts		5
Level control pump to camshaft housing		9

Note

Camshafts can be removed from an installed engine only together with the camshaft housing.

If a new camshaft has to be installed, the rocker arms must also be replaced.

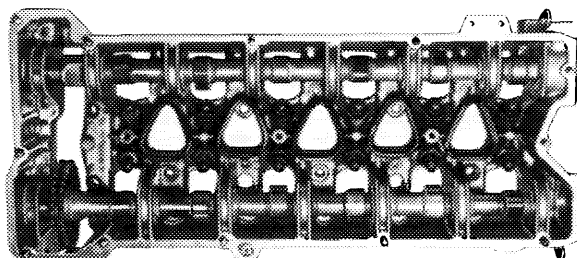

Camshafts with **wide** bearing journals (e.g. 21 mm) can be exchanged against camshafts with **narrow** bearing journals (arrow) (e.g. 16 mm).

Attention!

Exchange engines are partially delivered with camshaft bearing journals ground to intermediate or repair stage dimension (01–471).

Install camshafts with reground bearing journals in a camshaft housing with a pertinent bearing diameter (05–225).

Also refer to coordination camshaft housing and camshafts (01–471).

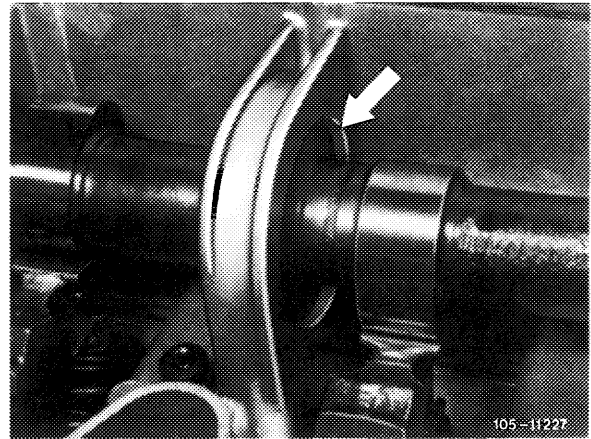

Removal

- 1 Remove camshaft housing (01–470).
- 2 Unscrew both rear covers on camshafts housing.
- 3 Unscrew necked-down screw of lefthand camshaft while applying counterhold with holding wrench.

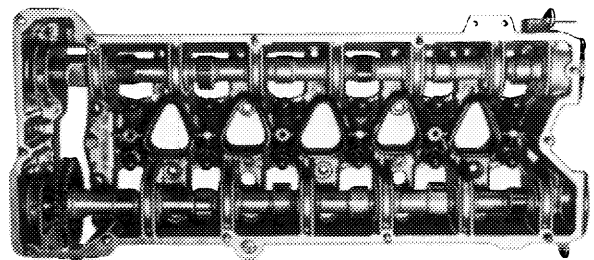

105-8003

- 4 Press back camshafts and remove camshaft sprocket.
- 5 Remove both camshafts toward rear.

Installation

6 Coat camshaft bearings with engine oil and guide in left camshaft (intake). Slide on camshaft sprocket (6) and spacer (5). Coat spacer (3) with engine oil and install.

Intake camshaft

- | | |
|------------------|---------------------|
| 1 Expansion bolt | 6 Camshaft sprocket |
| 2 Washer | 7 Woodruff key |
| 3 Spacer | 8 Camshaft |
| 4 Bearing | 10 Camshaft housing |
| 5 Spacer | |

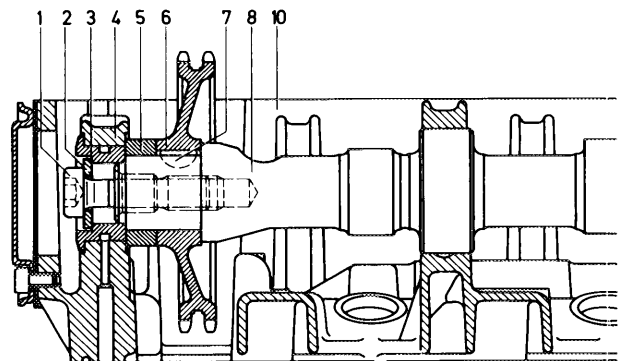

Z052 - 5027/1

7 Expansion bolt (3) with washer (2) must be installed for repair jobs. Mounting bolt (9) and spring washers (8) must not be used.

- 1 Spacer 2nd version without lubricating groove (for pressure oil pump and vacuum pump 2nd version)
- 2 Washer
- 3 Expansion bolt
- 4 Dog (for pressure oil pump and vacuum pump 2nd version)
- 5 Dog (for vacuum pump 1st version)
- 6 Dog 1st version (for pressure oil pump)
- 7 Spacer 1st version with lubricating groove
A = 4.7 mm for vacuum pump 1st version
A = 8.3 mm for pressure oil pump and vacuum pump 2nd version
- 8 Spring washers (not valid)
- 9 Mounting bolt (not valid)

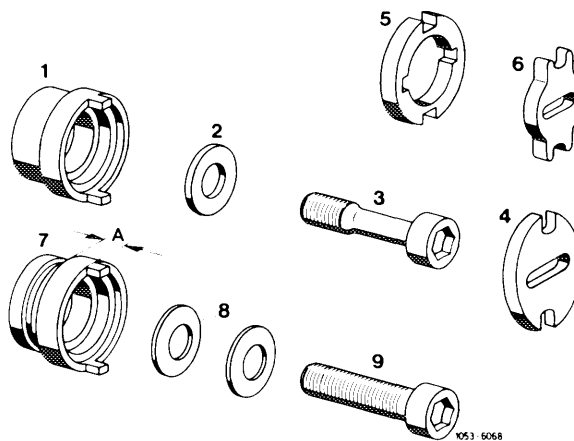

Note: Lubricating groove in spacing sleeve (arrow) no longer in place starting January 1974.

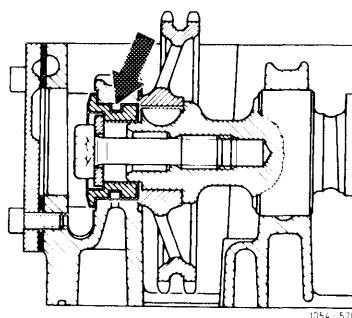

8 Tighten torque camshaft expansion bolt to 80 Nm (8 kpm), counterholding camshaft with a holding wrench.

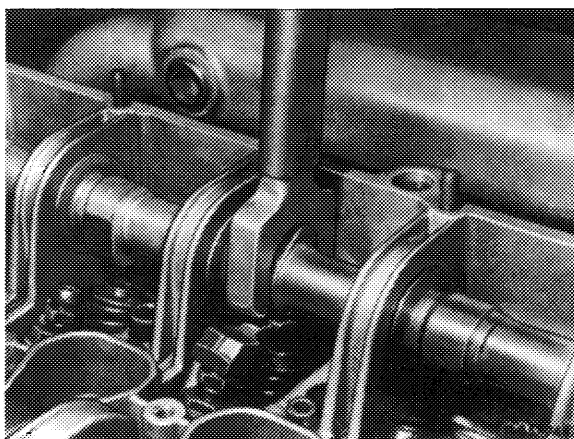

9 Guide right camshaft (exhaust) into lubricated bearings.

The right camshaft sprocket is installed after the camshaft housing has been mounted.

Exhaust camshaft

- 1 Expansion bolt
- 2 Washer
- 3 Spacer
- 4 Bearing
- 6 Camshaft sprocket
- 7 Woodruff key
- 9 Camshaft
- 10 Camshaft housing

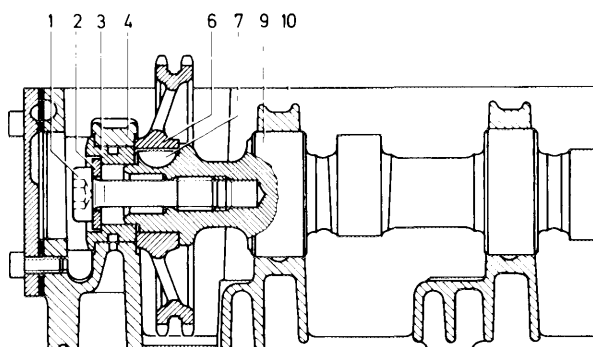

10 Install both rear covers with gaskets on camshaft housing.

11 Install camshaft housing (01-470).

