

Note

To prevent bypass faults (stage jump) from stage I to stage II, the bypass bores (arrow) are located 8 mm deeper under air valve starting January 1973 or starting carburetor cover code number "04", respectively. Subsequent installation is generally possible.

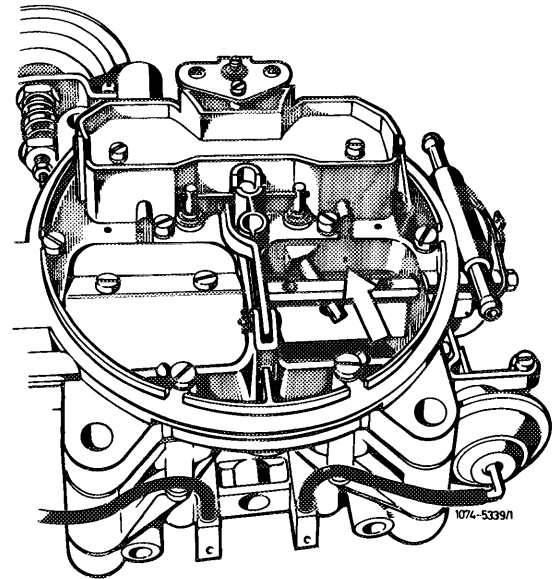

Scope

- 1 Remove carburetor cover, remove air valves of stage II.
- 2 Close former bypass bores by riveting with aluminum plugs of 2 mm dia. and, in similar alignment underneath, 8 mm above carburetor cover parting surface, drill a new bypass bore 2 mm dia. for each stage.

Carburetor cover code number

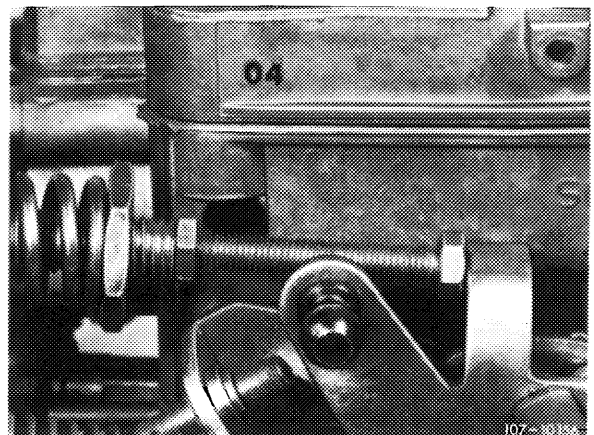

3 Blow through riser pipes (158) for stage II, install air valves, while paying attention to easy operation of valves.

4 Mount carburetor cover.

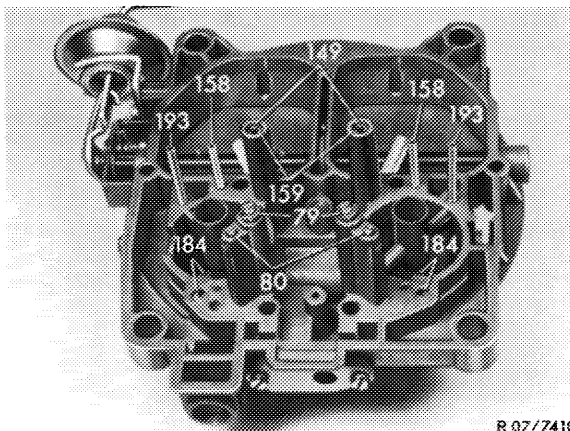

R 07/7410