

Oil circuit with air oil cooler

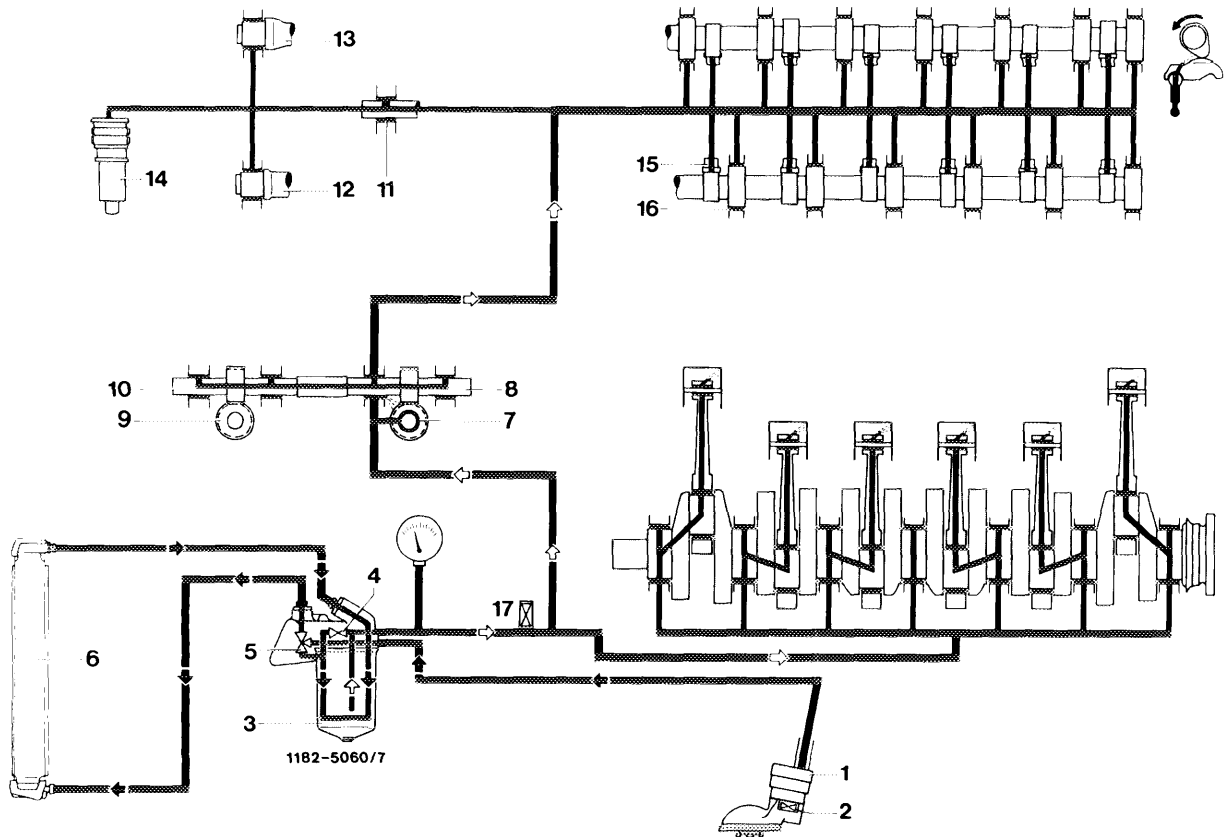

- |   |                                 |                             |   |
|---|---------------------------------|-----------------------------|---|
| 1 Oil pump  | 5 Thermostat with control valve | 9 Distributor drive         | 14 Chain tensioner                                      |
| 2 Pressure relief valve (7 bar) (built-in oil pump) | 6 Air oil cooler                | 10 Intermediate wheel shaft | 15 Rocker arms  |
| 3 Oil filter  | 7 Oil pump drive                | 11 Guide wheel              | 16 Camshaft bearings                                    |
| 4 Bypass valve filter element                       | 8 Intermediate wheel shaft      | 12 Intake camshaft          | 17 Pressure relief valve in front main oil bore (5 bar) |
|   |                                 | 13 Exhaust camshaft         |   |

**Attention!**

The oil circuit is controlled by a thermostat (5) in the oil filter upper section.

Starting at an oil temperature of approx. 95 °C or 110 °C (203 °F or 230 °F) beginning with model 126, the oil flows via air oil cooler. The bypass circuit is only opened as long as the oil temperature is below approx. 95 °C or 110 °C (203 °F or 230 °F).

If for any reason the air oil cooler (6) is disconnected or the connections on oil filter top are closed blind, **removal of thermostat with control valve and compression spring is absolutely required (18–125)**. If this is not done, the oil supply to the bearing points will be interrupted at oil temperatures above approx. 95 °C or 110 °C (203 °F or 230 °F).

## Oil circuit without air oil cooler

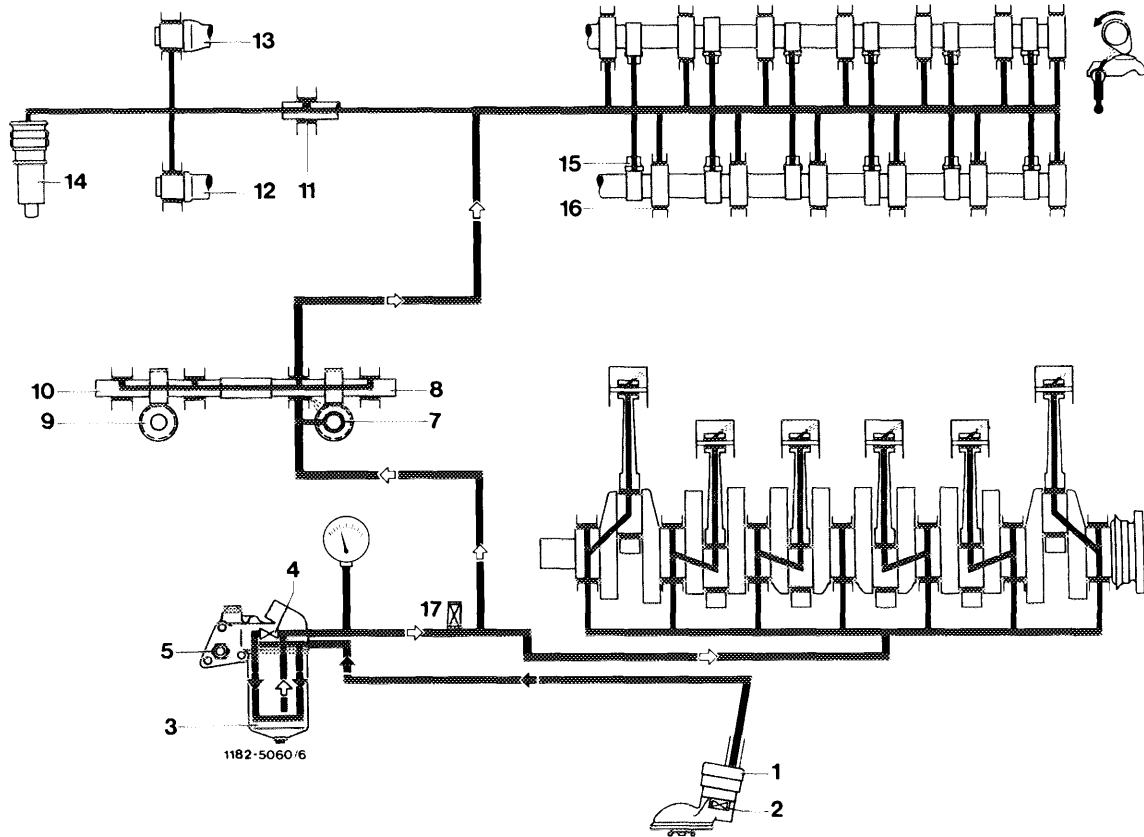

- |  |                             |                     |  |
|--|-----------------------------|---------------------|--|
| 1 Oil pump   | 5 17°C temperature switch   | 11 Guide wheel      | 15 Rocker arms   |
| 2 Pressure relief valve (7 bar)<br>(built in oil pump) | 7 Oil pump drive            | 12 Intake camshaft  | 16 Camshaft bearings                                       |
| 3 Oil filter   | 8 Intermediate wheel shaft  | 13 Exhaust camshaft | 17 Pressure relief valve<br>in front main oil bore (5 bar) |
| 4 Bypass valve filter element                          | 9 Distributor drive         | 14 Chain tensioner  |  |
|  | 10 Intermediate wheel shaft |                     |  |

## Oil pressure

At operating temperature the oil pressure at idle may drop to 0.5 bar gauge pressure.

Upon acceleration the oil pressure should immediately increase again and should attain min. 3 bar gauge pressure at 3000 rpm.

On model 126 the oil pressure is not indicated as before by means of a capillary tube connected to a pressure gauge in instrument cluster, but by means of a pressure transmitter which is electrically activated. The pressure transmitter is screwed to oil filter top (arrow).

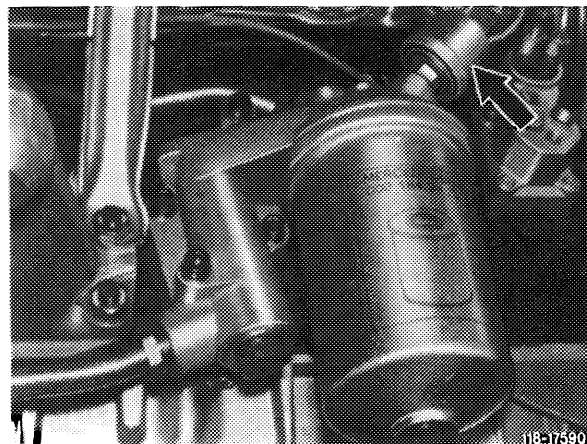

Oil filter with pressure transmitter

118-17590

**Opening pressures of pressure relief and bypass valve**

bar relief pressure

Pressure relief valve (2) for oil pump

7

Bypass valve (4) for filter cartridge

3.5

Pressure relief valve (17) in front main oil bore

5

**Oil filter models 107, 114, 116**

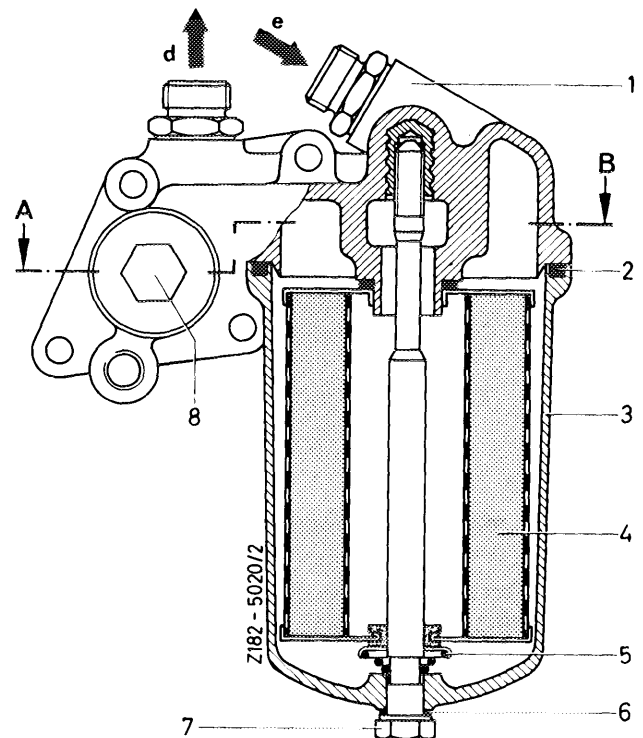

**Section A-B**

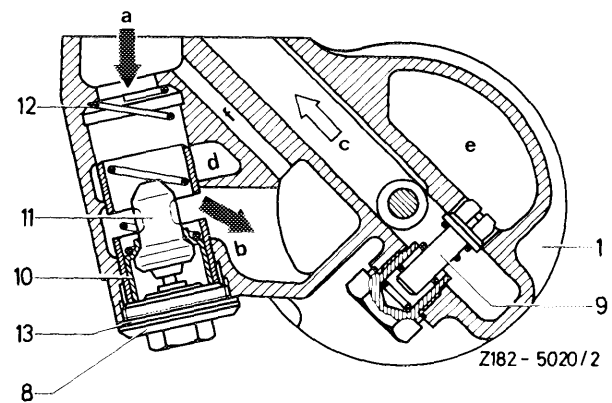

- 1 Filter upper section
- 2 Seal
- 3 Filter lower section
- 4 Filter cartridge
- 5 Spring with spring retainer
- 6 Seal
- 7 Hex. head screw
- 8 Plug
- 9 Bypass valve — filter cartridge
- 10 Control valve
- 11 Thermostat
- 12 Spring
- 13 Seal

- a from oil pump
- b to filter lower section
- c to bearings
- d to air oil cooler
- e from air cooler to filter lower section
- f bypass bore

**Oil filter model 123 and models 107, 116 with continuous fuel injection, 2nd version carburetor engine**

- |                                 |                       |
|---------------------------------|-----------------------|
| 1 Filter upper section          | 11 Plug               |
| 2 Spring                        | 12 Seal               |
| 3 Oil pressure gage connection  | 13 Thermostat         |
| 4 Bypass valve/filter cartridge | 14 Control valve      |
| 5 Seal                          | 15 Spring             |
| 6 Filter lower section          |                       |
| 7 Filter cartridge              | a to air oil cooler   |
| 8 Spring with spring retainer   | b from air oil cooler |
| 9 Seal                          | c from oil pump       |
| 10 Hex. head screw              | d to bearings         |

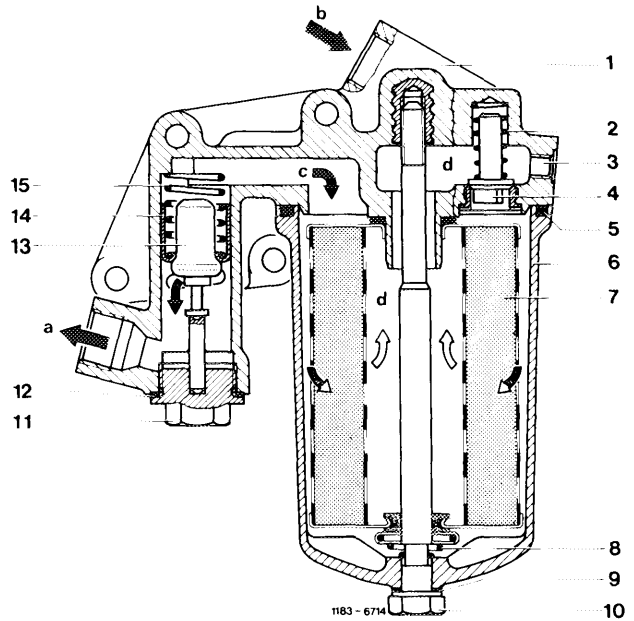

**Oil filter, model 114 USA version**

Model 280 (114.060) up to chassis end No. 014 231  
 Model 280 C (114.073) up to chassis end No. 003 384

- |  |                                       |
|--|---------------------------------------|
| 1 Filter upper section                   | 6 Filter lower section                |
| 2 Oil pressure gage connection           | 7 Spring with spring retainer         |
| 3 Plug for filter cartridge bypass valve | 8 Seal                                |
| 4 Seal                                   | 9 Hex. head screw                     |
| 5 Filter cartridge                       | 10 17°C temperature switch connection |
|  | 11 Plugs                              |

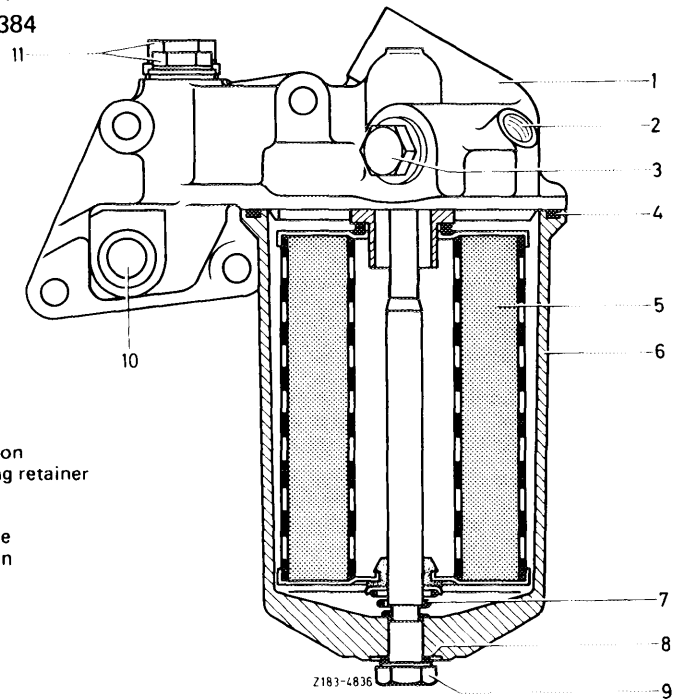

**Oil filter models 114 and 116.020  
USA and Sweden version**

Model 280 (114.060) from chassis end No. 014 232  
Model 280 C (114.073) from chassis end No. 003 385

**Note:** Oil filters up to and from the specified chassis end numbers are interchangeable.

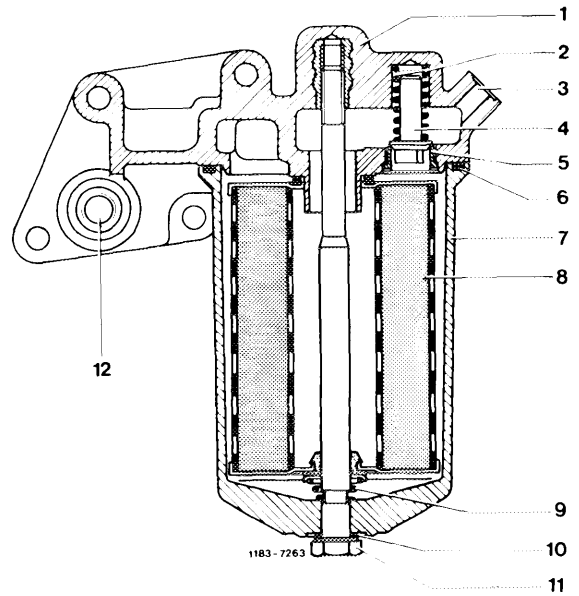

- |                                 |                                       |
|---------------------------------|---------------------------------------|
| 1 Filter upper section          | 8 Filter cartridge                    |
| 2 Spring                        | 9 Spring with spring retainer         |
| 3 Oil pressure gage connection  | 10 Seal                               |
| 4 Filter cartridge bypass valve | 11 Hex. head screw                    |
| 5 Valve seat                    | 12 17°C temperature switch connection |
| 6 Seal                          |                                       |
| 7 Filter lower section          |                                       |

**Oil filter without air oil cooler, model year 1977**

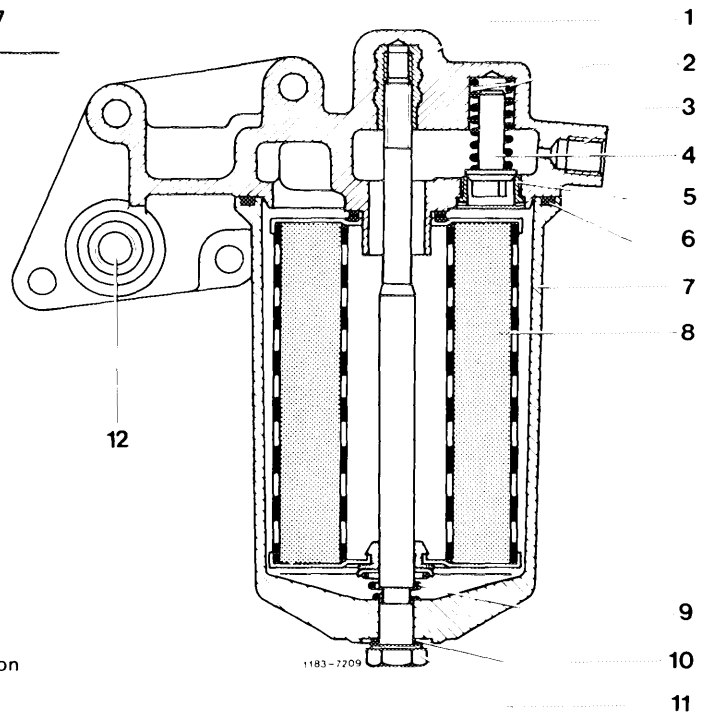

- |                                       |
|---------------------------------------|
| 1 Filter upper section                |
| 2 Spring                              |
| 3 Oil pressure gage connection        |
| 4 Filter cartridge bypass valve       |
| 5 Valve seat                          |
| 6 Seal                                |
| 7 Filter lower section                |
| 8 Filter cartridge                    |
| 9 Spring with spring retainer         |
| 10 Seal                               |
| 11 Hex. head screw                    |
| 12 17°C temperature switch connection |

**Oil filter model 126 without air oil cooler**

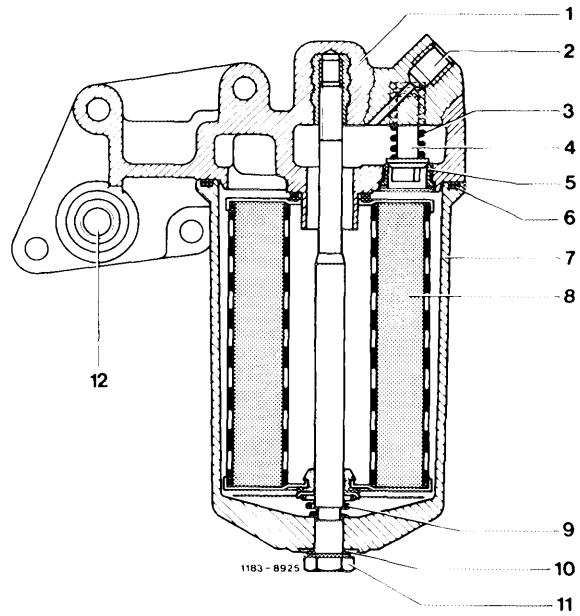

- |   |   |
|---|---|
| 1 Filter top                              | 7 Filter lower section                    |
| 2 Connection for oil pressure transmitter | 8 Filter cartridge                        |
| 3 Compression spring                      | 9 Compression spring with spring retainer |
| 4 Filter cartridge bypass valve           | 10 Sealing ring                           |
| 5 Valve seat                              | 11 Hex. head screw                        |
| 6 Sealing ring                            | 12 17 °C temperature switch connection    |

**Oil filter model 126 with air oil cooler**

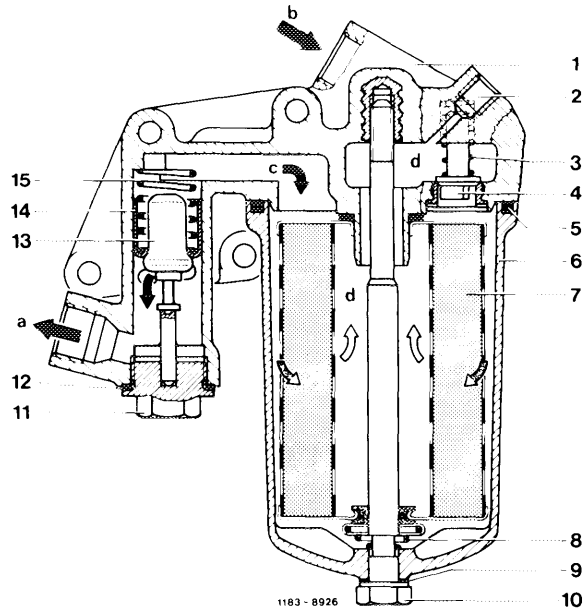

- |   |                       |
|---|-----------------------|
| 1 Filter upper section                    | 10 Hex. head screw    |
| 2 Connection for oil pressure transmitter | 11 Closing plug       |
| 3 Compression spring                      | 12 Sealing ring       |
| 4 Filter cartridge bypass valve           | 13 Thermostat         |
| 5 Sealing ring                            | 14 Control valve      |
| 6 Filter lower section                    | 15 Compression spring |
| 7 Filter cartridge                        | a To air oil cooler   |
| 8 Compression spring with spring retainer | b From air oil cooler |
| 9 Sealing ring                            | c From oil pump       |
|   | d To bearing points   |

## Note

---

Engines 110 are provided with oil filter elements of engines 116, 117 as standard equipment. The part no. of the filter element on oil filter bowl has been changed from the former 000 184 98 25 to 00 184 99 25.

The former filter element, part no. 000 184 98 25 is valid as a running-in filter up to 1st inspection.

Starting 1980, the oil filters, part no. 001 184 64 25 are valid as running-in filters or 001 184 65 25 as constant operation filters.

When the oil filter is removed, remainders of gasket may stick to flange surface of cylinder crankcase.

To prevent such remainders from entering the pure oil duct of the cylinder crankcase during removal (e.g. by scraping), the bores should be covered or closed first.

New oil filters are supplied with running-in filter elements which may be used on new engines up to first inspection.

These filter elements have a restricted operating life and should be exchanged against normal filter elements when new oil filters are installed on run-in engines.

To prevent that the former gasket (A), part no. 110 184 03 80, is pushed out and thereby made leaking, the present version (B), part no. 110 184 05 80, is perforated only in range of forward or return flow.

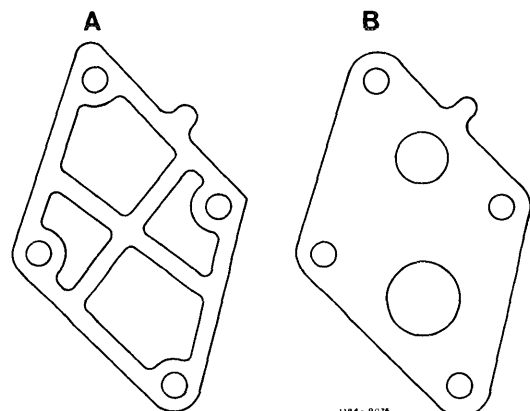

1184 - 9076

## Standard application

Engine	starting engine end no.	automatic transmission
	manual transmission	
110.922	040354	067119
110.923	013226	017239
110.932	010320	002765
110.984	019263	065273
110.985	013841	068010
110.986	003040	006862

Oil filling capacity in liters	Oil dipstick color code	
	pink/wine red	yellow/green
Refill capacity (dry engine)	7.5 <sup>1)</sup>	7 <sup>1)</sup>
Total filling capacity during oil and filter change	6.5	6
Oil pan max./min.	6/4.5	5.5/4

<sup>1)</sup> On vehicles without air oil cooler deduct 0.5 liter refill capacity from total filling capacity.

## Oil level checkup

The oil level depends, among others, from oil temperature and return flow period of oil after stopping the engine. For this reason, measure oil level only approx. 2 minutes after stopping worn engine.

Prior to checking oil level, always pull out dipstick first and wipe off.

## Air oil cooler

Model 126.021 with engine 110.924 is not provided with an air oil cooler.

Models 126.022/023 are provided with a double tube light alloy air oil cooler.

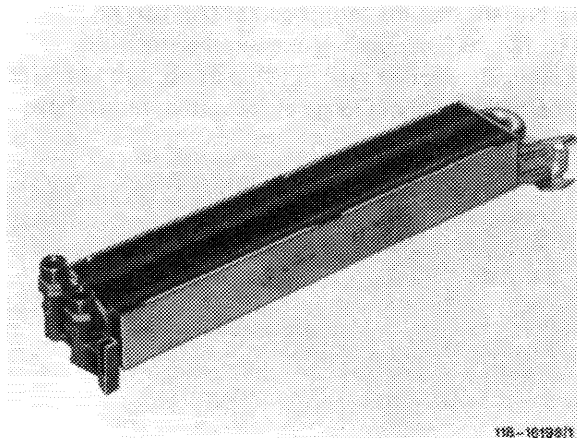

Double tube light alloy air oil cooler

Y18--1019071