

Model year 1977/78/79

A. Federal version, tourist vehicles Federal version

For complaints such as: Poor warming-up characteristics of engine, poor idle speed, engine not accelerating or splashing during acceleration, check emission control system for function.

Test conditions: Engine at operating temperature, run engine at idle speed.

Test the following: EGR, air injection and fuel evaporation control system.

Function diagram model year 1977

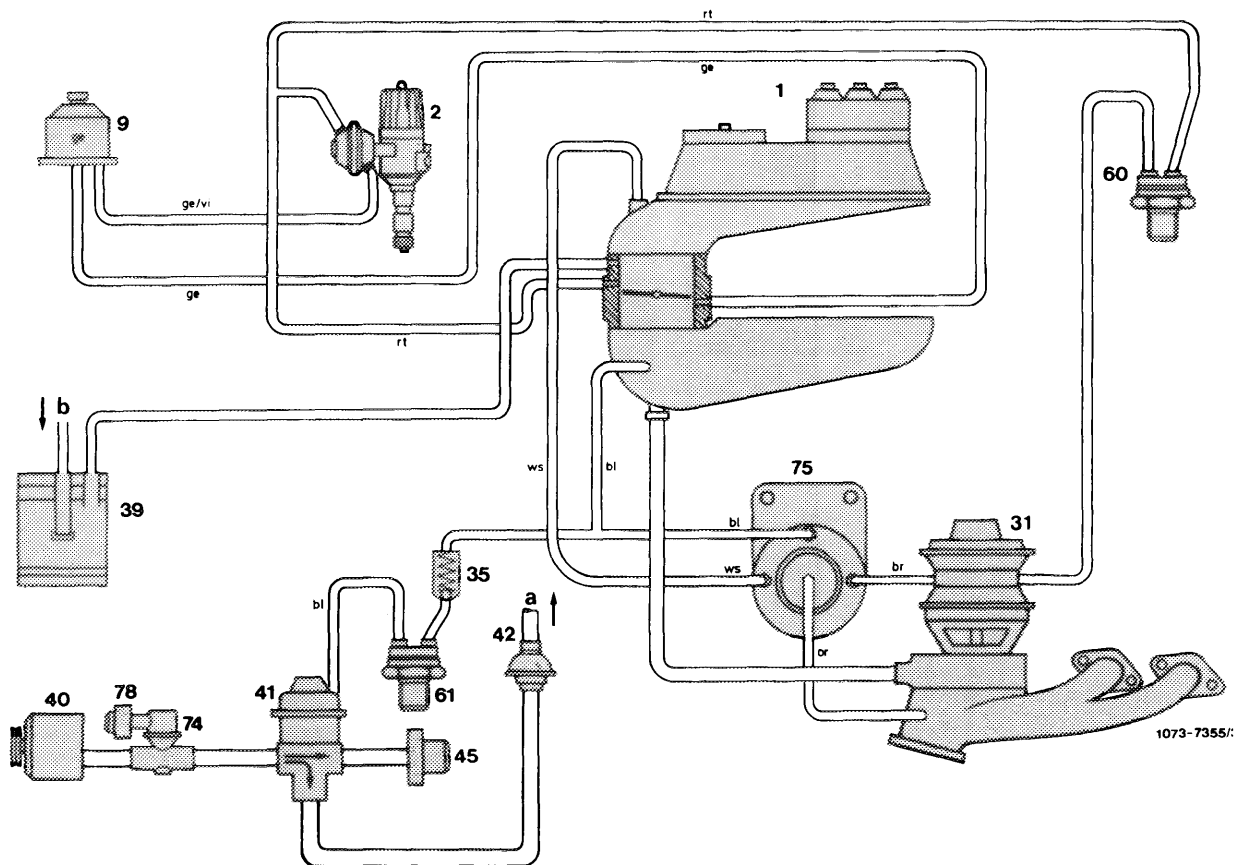

- 1 Mixture controller
- 2 Ignition distributor
- 9 Switch-over valve ignition
- 31 EGR valve
- 35 Check valve

- 39 Charcoal canister
- 40 Air pump
- 41 Diverter valve (air switch-over valve)
- 42 Check valve
- 45 Air filter

- 60 Thermovalve 40 °C
- 61 Thermovalve 17 °C
- 74 Pressure relief valve
- 75 Pressure transducer
- 78 Air filter for silencing

- a Air injection line
- b Connection tank vent

Function diagram model year 1978/79

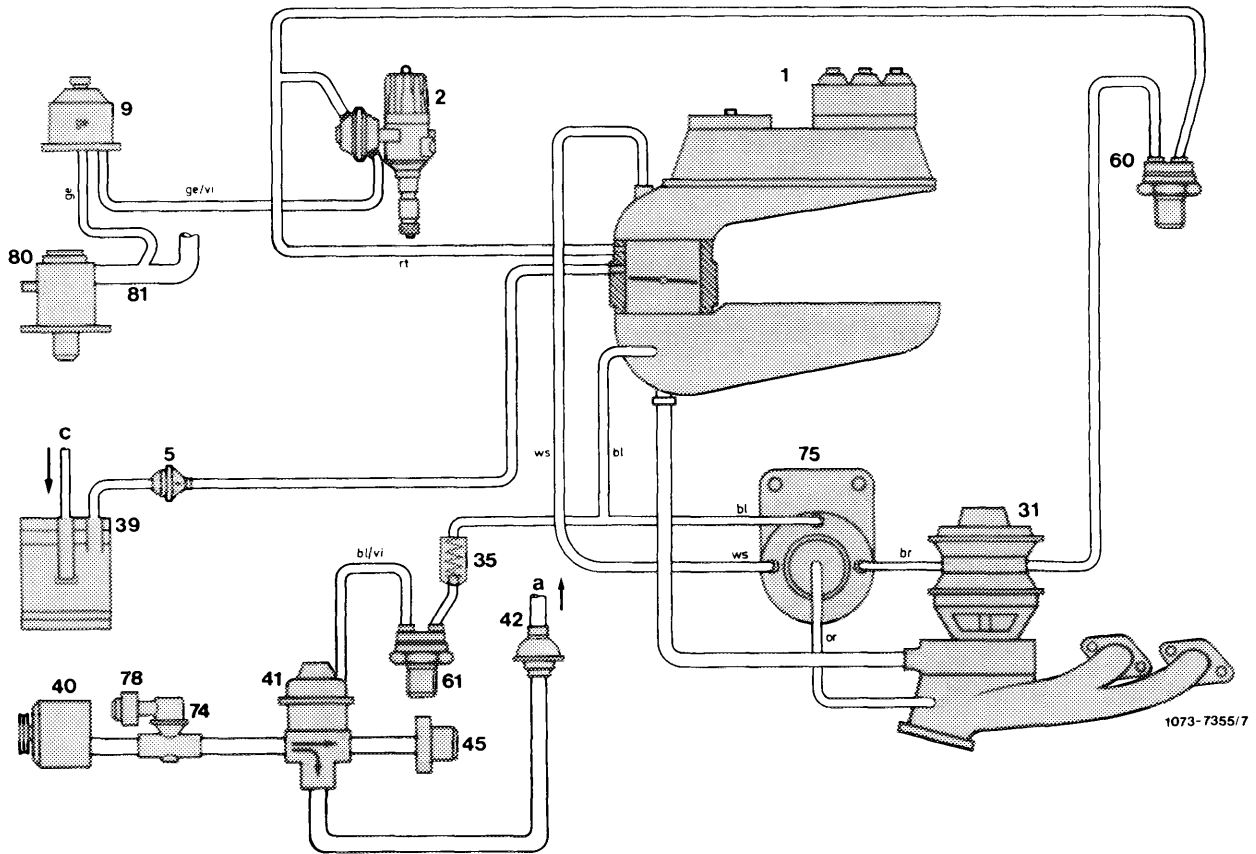

- | | | | |
|------------------------------------|---|--------------------------|-----------------------------|
| 1 Mixture controller | 35 Check valve | 45 Air filter | 78 Air filter for silencing |
| 2 Ignition distributor | 39 Charcoal canister | 60 Therموvalve 40 °C | 80 Auxiliary air valve |
| 5 Regenerating valve (purge valve) | 40 Air pump | 61 Therموvalve 17 °C | 81 Contour hose |
| 9 Switch-over valve ignition | 41 Diverter valve (air switch-over valve) | 74 Pressure relief valve | a Air injection line |
| 31 EGR valve | 42 Check valve | 75 Pressure transducer | b Connection tank vent |

Testing EGR

Pull brown vacuum line from EGR valve (31) and slowly increase idle speed.

Engine runs irregularly starting at approx. 1200/min or stops.

Engine runs without change.

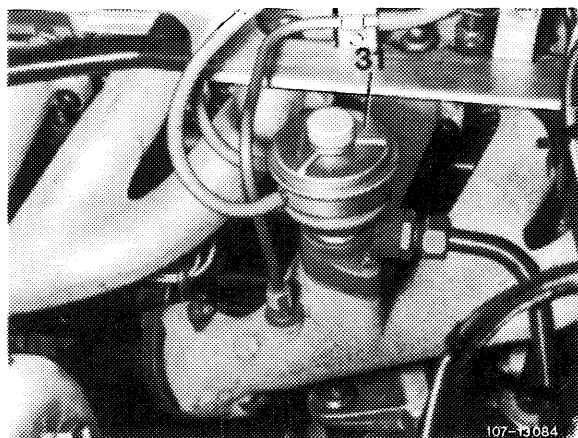

Testing vacuum lines

Test layout of vacuum lines on pressure transducer and intake pipe.

Note that connections on pressure transducer are identified with color rings. The attached vacuum lines should have the same color.

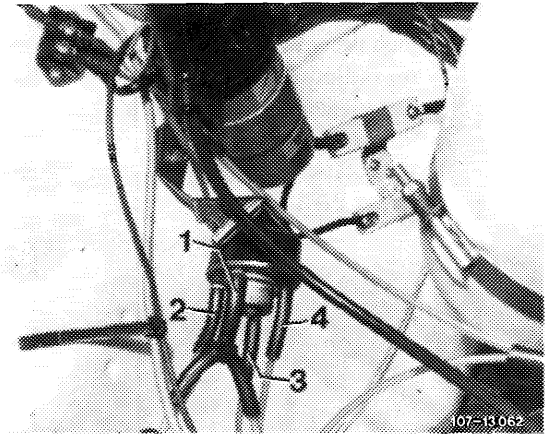

- 1 Connection intake pipe vacuum (blue)
- 2 Connection vent line (white)
- 3 Connection exhaust gas backpressure line (orange)
- 4 Connection vacuum line to EGR valve (brown)

On black thermovalve 40 °C (60) the red vacuum line should be plugged to diagonal connection, and the rubber hose to straight connection. Check all pertinent vacuum lines for leaks and blow out vacuum connections.

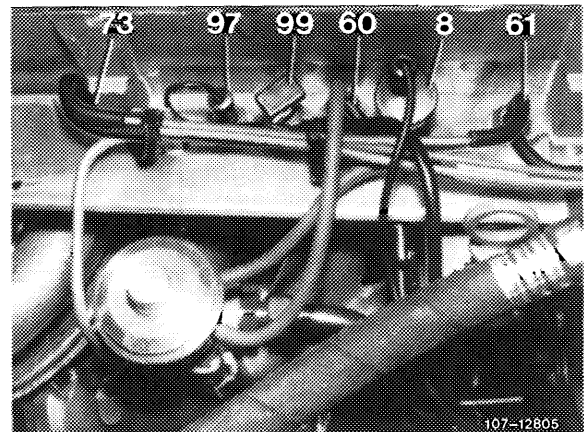

Testing thermovalve 40 °C (60)

The thermovalve is identified by a black plastic section and the designation "50 AA 4" punched into metal section. Pull-off vacuum hose at straight connection, let engine run and accelerate.

Vacuum should be felt at free connection.

During removal and installation of thermovalve make sure that the small connecting pipes are not damaged.

Testing pressure transducer (75)

Run engine at idle speed. Pull-off brown vacuum line on EGR valve. Connect vacuum pressure gauge or keep vacuum line closed with finger. Vacuum should be available at idle speed.

If there is no vacuum, renew pressure transducer.

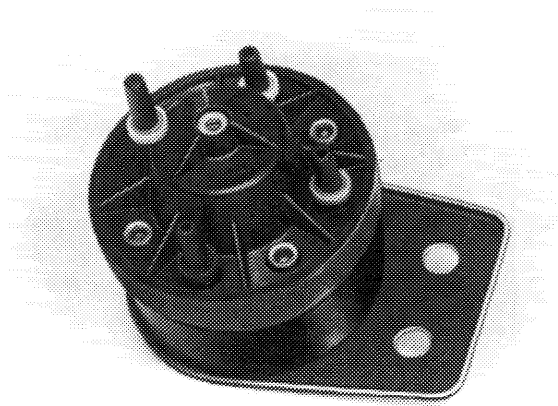

107-12314

Testing EGR valve (31)

Run engine at idle speed. Pull-off both hoses on EGR valve.

Plug brown vacuum line to connection for red/purple vacuum line. Engine should run irregularly or come to a stop.

If operation of engine is not changing, renew EGR valve.

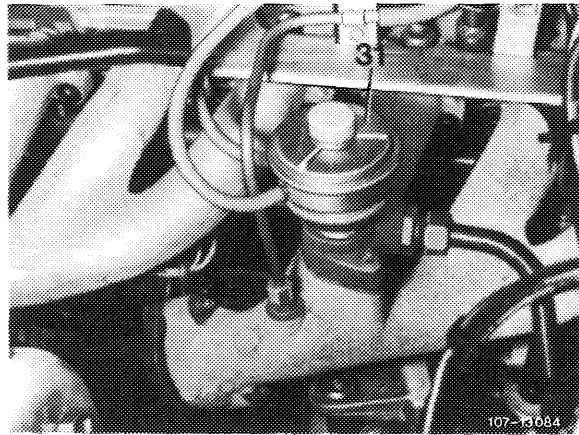

107-13084

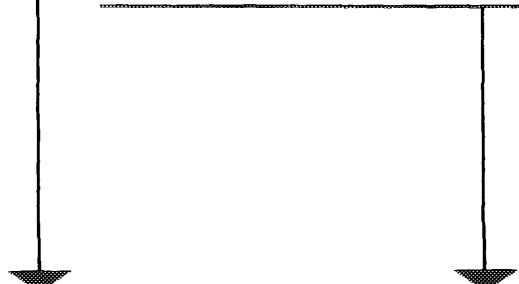

Testing air injection

Connect CO measuring instrument and read exhaust gas value. Pull vacuum line from straight connection of thermovalve (61) and close connection.

Exhaust gas value increasing.

Exhaust gas value not increasing.

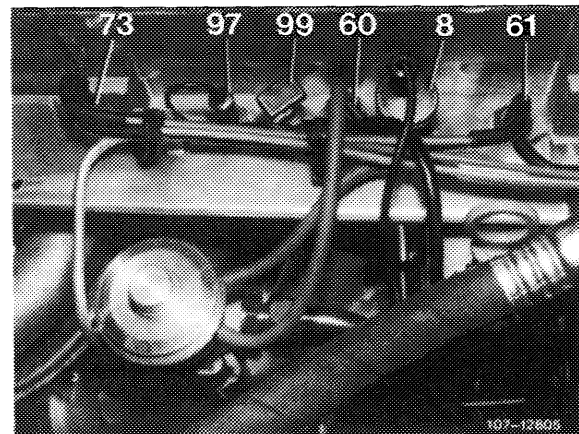
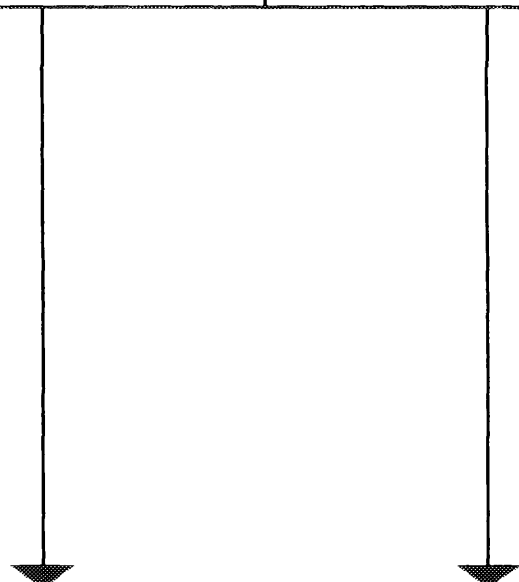

107-12608

Testing vacuum lines

The blue vacuum line from intake pipe should be connected to blue line and diagonal connection of thermovalve (61) by means of a distributor and check valve. The check valve should be plugged on with connection (A) in direction of intake pipe.

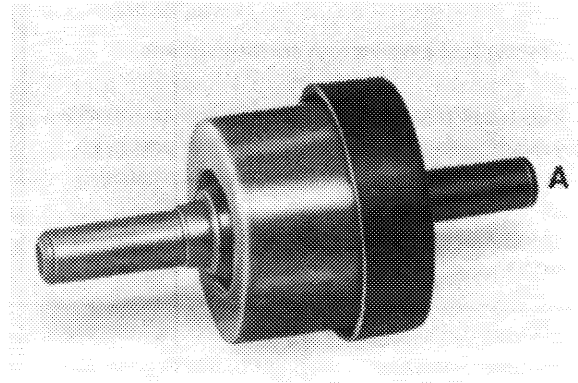

107-12701/1

The blue/purple vacuum line of straight connection of thermovalve (61) leads to diverter valve (41).

Testing vacuum

Pull vacuum line from diagonal connection of thermovalve (61), connect vacuum gauge or keep closed with finger. Vacuum should be available at idle speed. If not, test vacuum lines for leaks and blow out vacuum draw-off line (tapping line) at intake pipe.

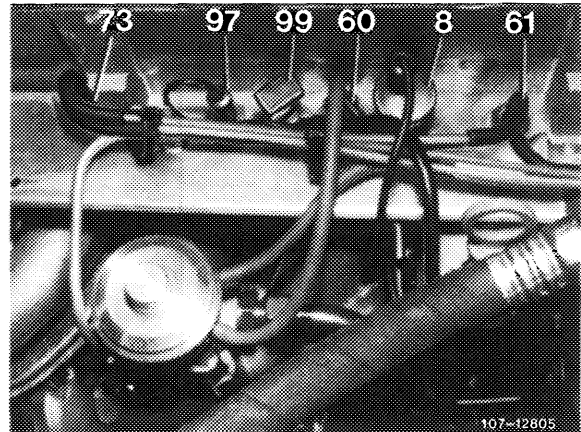

107-12805

If vacuum is available, test thermovalve (61) and renew, if required.

Testing thermovalve 17 °C (61)

The thermovalve is identified by a blue plastic section and the designation "50 AB 5" punched into metal section.

Pull-off blue/purple vacuum line, run engine.

Vacuum should be available at free connection.

If thermovalve is in order, renew diverter valve (41).

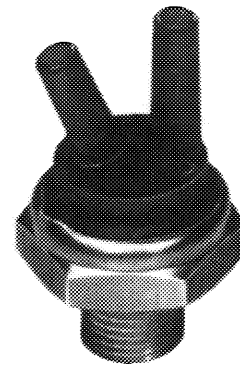

107-10895

Testing fuel evaporation control system

Pull black plastic line (draw-off line) to throttle valve housing from charcoal canister and keep closed with finger or connect vacuum gauge.

Slowly increase engine speed to above approx. 2000/min.

No vacuum at idle.
Vacuum increases
with increasing
speed.

No vacuum increase
at increasing speed.

Model year 1977

Testing draw-off hose

The draw-off hose should be plugged to throttle valve housing (arrow). Check hose for leaks and blow out connection on throttle valve housing.

Model year 1978/79

Testing draw-off hose and regenerating valve

The draw-off hose should be plugged to throttle valve housing (arrow). Check hose for leaks and blow out connection on throttle valve housing.

If there is still no vacuum, pull draw-off hose in front of regenerating valve and repeat test.

If vacuum is available, renew regenerating valve.

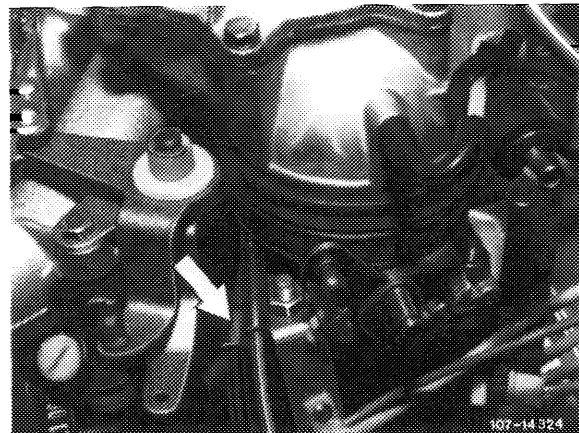

End of test

B. California version

For complaints such as: Poor warming-up characteristics of engine, poor idle speed, engine not accelerating or splashing during acceleration, check emission control system for function.

Test conditions: Engine at operating temperature, run engine at idle speed.

Test the following: EGR, air injection and fuel evaporation control system.

Function diagram model year 1977

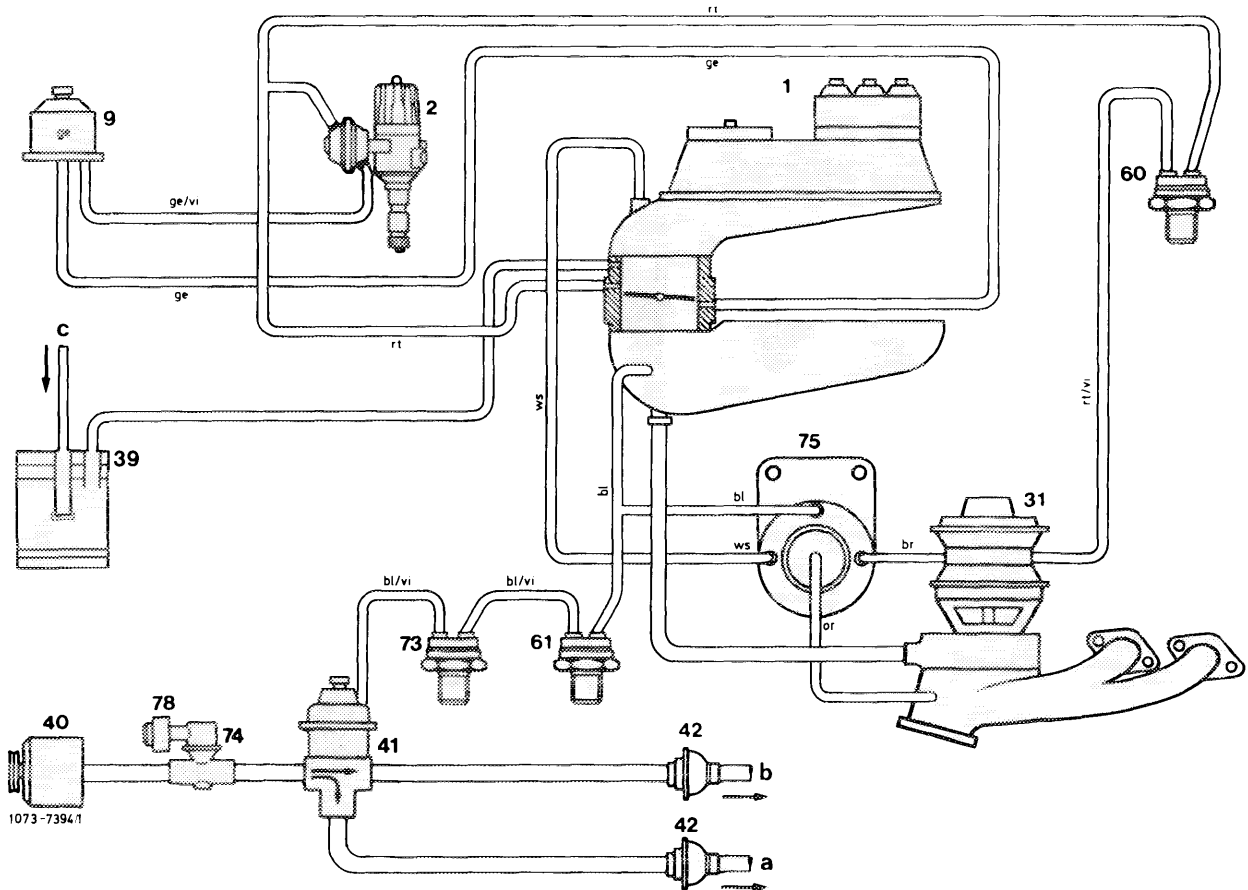

- 1 Mixture controller
- 2 Ignition distributor
- 9 Switch-over valve ignition
- 31 EGR valve
- 39 Charcoal canister

- 40 Air pump
- 41 Air switch-over valve
- 42 Check valve
- 60 Thermostatic valve 40 °C

- 61 Thermostatic valve 17 °C
- 73 Thermostatic valve 50 °C
- 74 Pressure relief valve
- 75 Pressure transducer

- 78 Air filter for silencing
- a Air injection line cylinder head
- b Air injection line between catalyts
- c Connection tank vent

Function diagram model year 1978/79

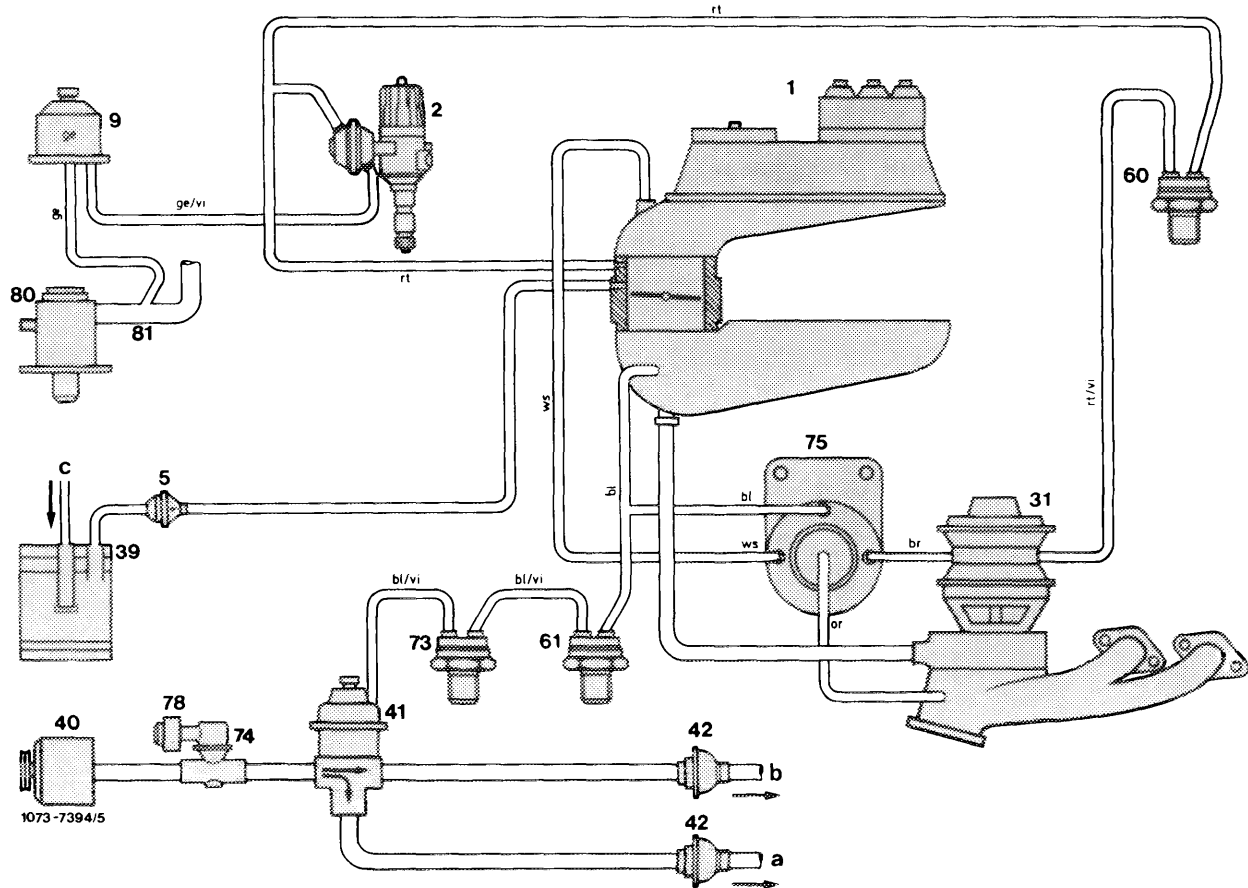

- | | | | |
|------------------------------|--------------------------|-----------------------------|---------------------------------------|
| 1 Mixture controller | 39 Charcoal canister | 61 Thermovalve 17 °C | 80 Auxiliary air valve |
| 2 Ignition distributor | 40 Air pump | 73 Thermovalve 50 °C | 81 Contour hose |
| 5 Regenerating valve | 41 Air switch-over valve | 75 Pressure transducer | a Air injection line cylinder head |
| 9 Switch-over valve ignition | 42 Check valve | 78 Air filter for silencing | b Air injection line between catalyts |
| 31 EGR valve | 60 Thermovalve 40 °C | | c Connection tank vent |

Testing EGR	
Pull-off brown vacuum line on EGR valve (31) and slowly increase idle speed.	
Engine runs irregularly starting at approx. 1200/min or comes to a stop.	Engine operation continues without stop.

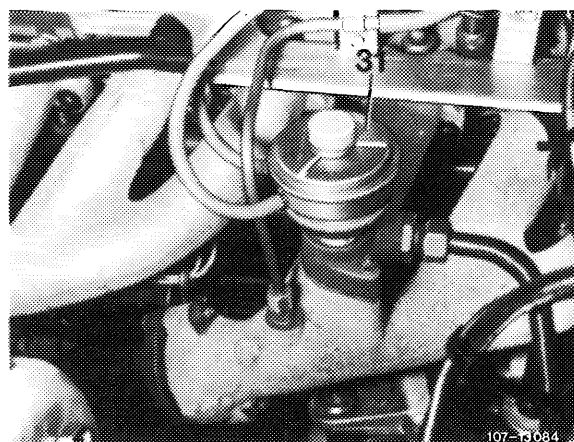

Testing vacuum lines

Test layout of vacuum lines on transducer and intake pipe.

Note that connections on pressure transducer are identified with color rings. The plugged-on vacuum lines should have the same color.

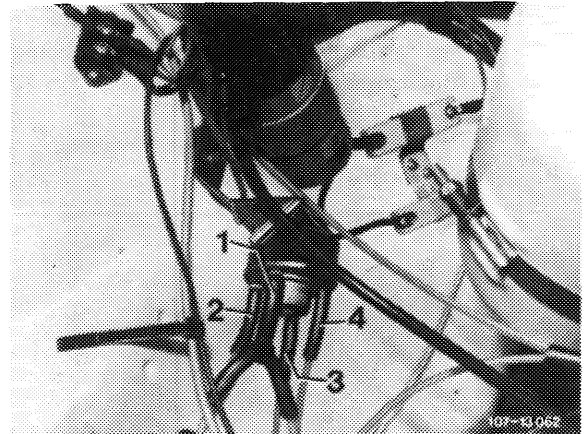

- 1 Connection intake pipe vacuum (blue)
- 2 Connection vent line (white)
- 3 Connection exhaust gas backpressure line (orange)
- 4 Connection vacuum line to EGR valve (brown)

On black thermovalve 40 °C (60) the red vacuum line should be connected to diagonal connection, and the rubber hose to straight connection. Check all pertinent vacuum lines for leaks and blow out vacuum draw-off connections.

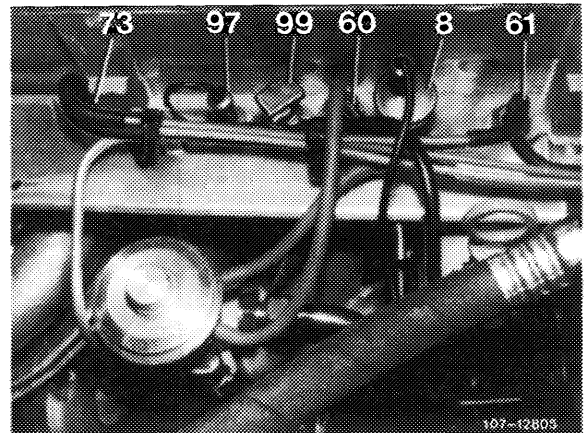

Testing thermovalve 40 °C (60)

The thermovalve is identified by black plastic section and by the designation "50 AA 4" punched into metal section. Pull-off vacuum hose at straight connection, keep engine running and accelerate.

Vacuum should be available at free connection.

When removing and installing thermovalve, make sure that the small connecting pipes are not damaged.

Test pressure transducer (75)

Run engine at idle. Pull-off brown vacuum line on EGR valve. Connect vacuum gauge or keep vacuum line closed with finger. Vacuum should be available at idle speed.

If there is no vacuum, renew pressure transducer.

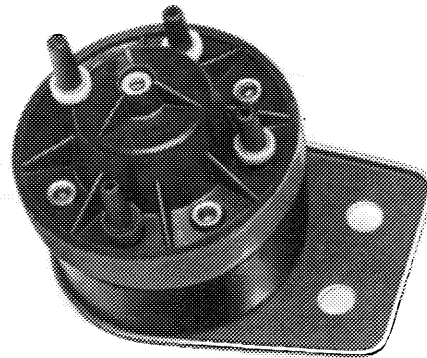

107-12314

Test EGR valve (31)

Run engine at idle speed. Pull-off both hoses on EGR valve.

Plug brown vacuum line to connection for red/purple vacuum line. Engine should run irregularly or come to a stop.

If operation of engine is not changing, renew EGR valve.

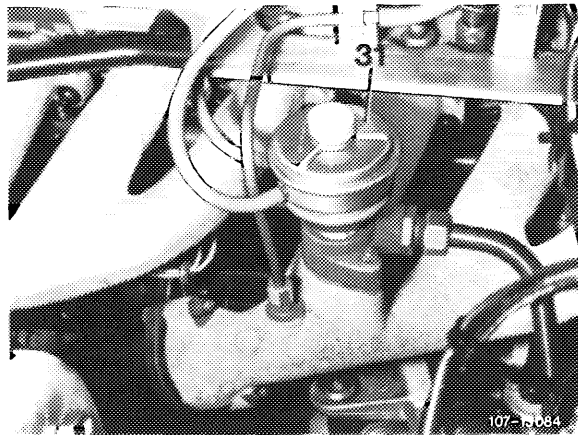

107-12084

Testing air injection

Connect CO measuring instrument to exhaust gas backpressure line and read exhaust gas emission value. Change vacuum hose from straight plug connection of thermostatic valve (73) to straight plug connection of thermostatic valve (61).

Exhaust gas value clearly decreasing.

Exhaust gas value not decreasing.

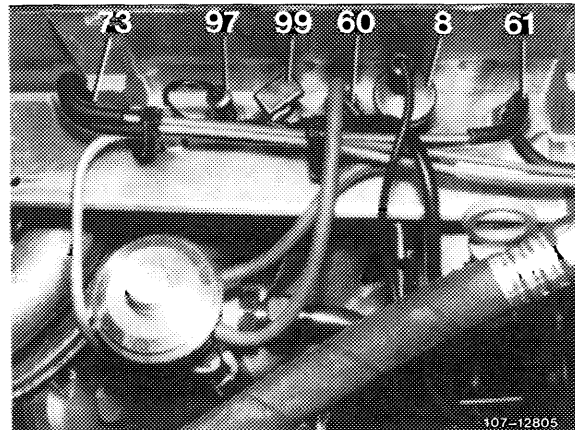

107-12805

Test vacuum lines

The blue vacuum line from intake pipe should be connected to diagonal connection of thermovalve (61) by means of a distributor. The purple/blue vacuum line leads from straight connection of thermovalve (61) to diagonal connection of thermovalve (73) and from straight connection of thermovalve (73) to air switch-over valve (41).

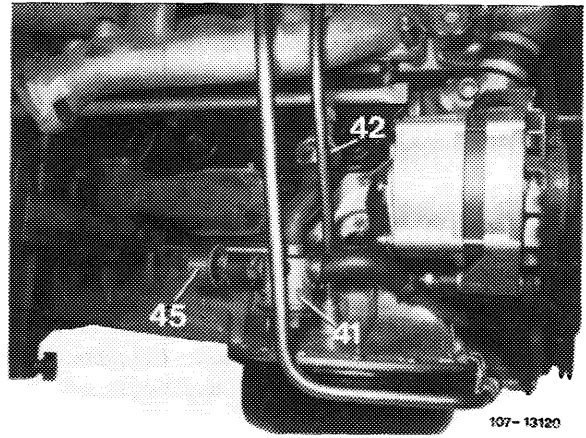

Test vacuum

Check at straight connection of thermovalve (61) for vacuum. If vacuum is available, renew air switch-over valve (41).

If there is no vacuum:

Pull-off blue vacuum line on thermovalve (61) and check for vacuum.

If vacuum is available:

Renew thermovalve (61).

If there is no vacuum:

Remove vacuum line to intake pipe and blow out with compressed air.

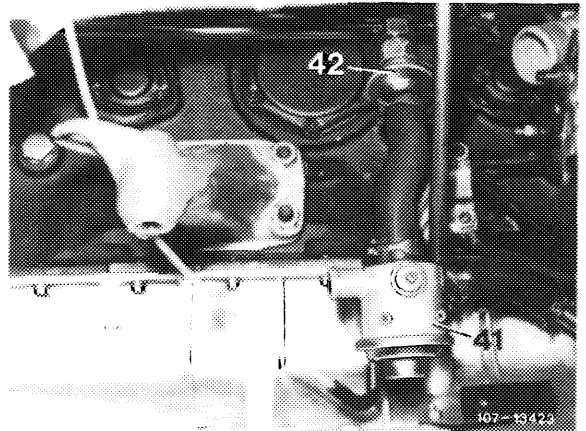

Test thermovalve (73)

If upon completion of the above jobs the exhaust gas value is still not decreasing, test thermovalve (73) for passage and renew, if required.

Below approx. 50 °C thermovalve is open, above approx. 50 °C valve is closed.

The thermovalve is identified by black plastic section with a green color dot and by the designation "50 AA 13" punched into metal section.

Note: Starting model year 1978 the identifying color is green, designation "50 AC 13".

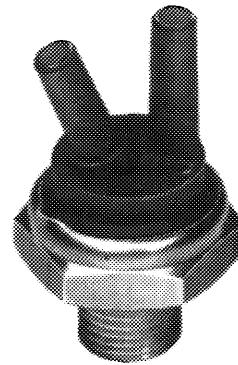

Testing fuel evaporation control system

Pull-off black plastic line (draw-off line) to throttle valve housing from charcoal canister and keep closed with finger or connect vacuum gauge.

Slowly increase engine speed to above approx. 2000/min.

No vacuum at idle.
Vacuum increasing
at increasing speed.

Vacuum not increasing
at increasing speed.

Model year 1977

Test draw-off hose

Draw-off hose must be plugged to throttle valve housing (arrow). Check hose for leaks and blow out connection on throttle valve housing.

Model year 1978/79

Test draw-off hose and regenerating valve (purge valve)

Draw-off hose should be plugged to throttle valve housing (arrow). Check hose for leaks and blow out connection on throttle valve housing.

If there is still no vacuum, pull-off draw-off hose in front of regenerating valve and repeat test.

If vacuum is available, renew regenerating valve (purge valve).

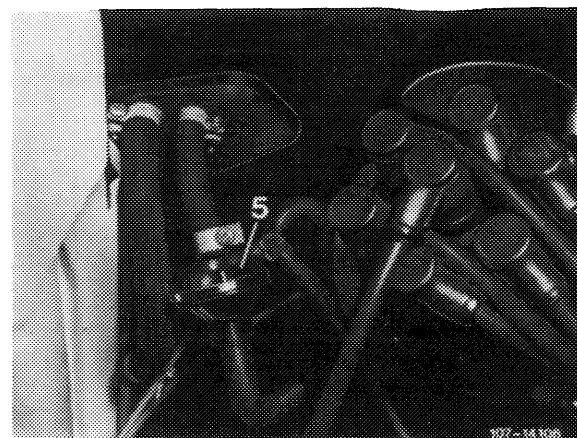
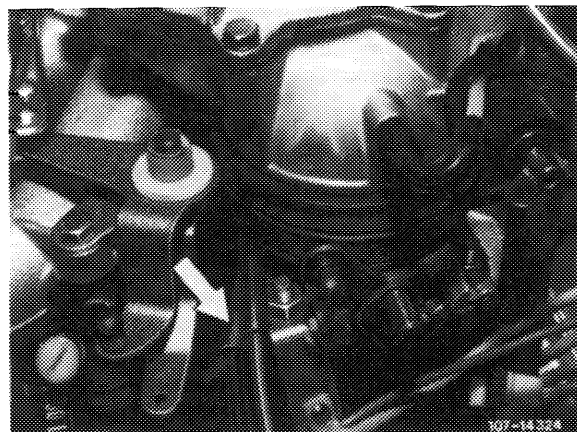

End of test

C. Tourist vehicles California version

For complaints such as: Poor warming-up characteristics of engine, poor idle speed, engine not accelerating or splashing during acceleration, check emission control system for function.

Test conditions: Engine at operating temperature, run engine at idle speed.

Test the following: EGR, air injection and fuel evaporation control system.

Function diagram model year 1977

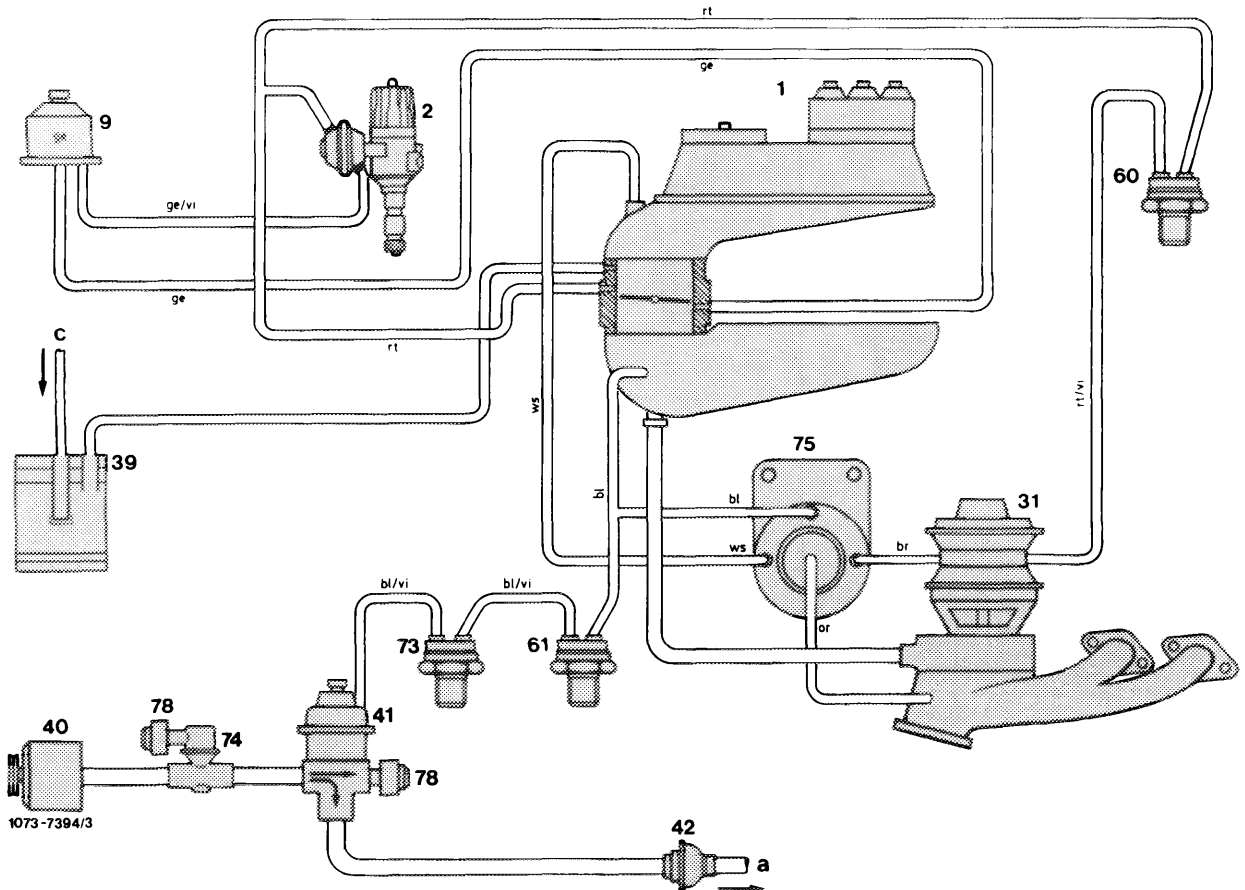

- | | | | |
|------------------------------|--------------------------|-----------------------------|------------------------------------|
| 1 Mixture controller | 39 Charcoal canister | 60 Thermostatic valve 40 °C | 75 Pressure transducer |
| 2 Ignition distributor | 40 Air pump | 61 Thermostatic valve 17 °C | 78 Air filter for silencing |
| 9 Switch-over valve ignition | 41 Air switch-over valve | 73 Thermostatic valve 50 °C | a Air injection line cylinder head |
| 31 EGR valve | 42 Check valve | 74 Pressure relief valve | c Connection tank vent |

Function diagram model year 1978/79

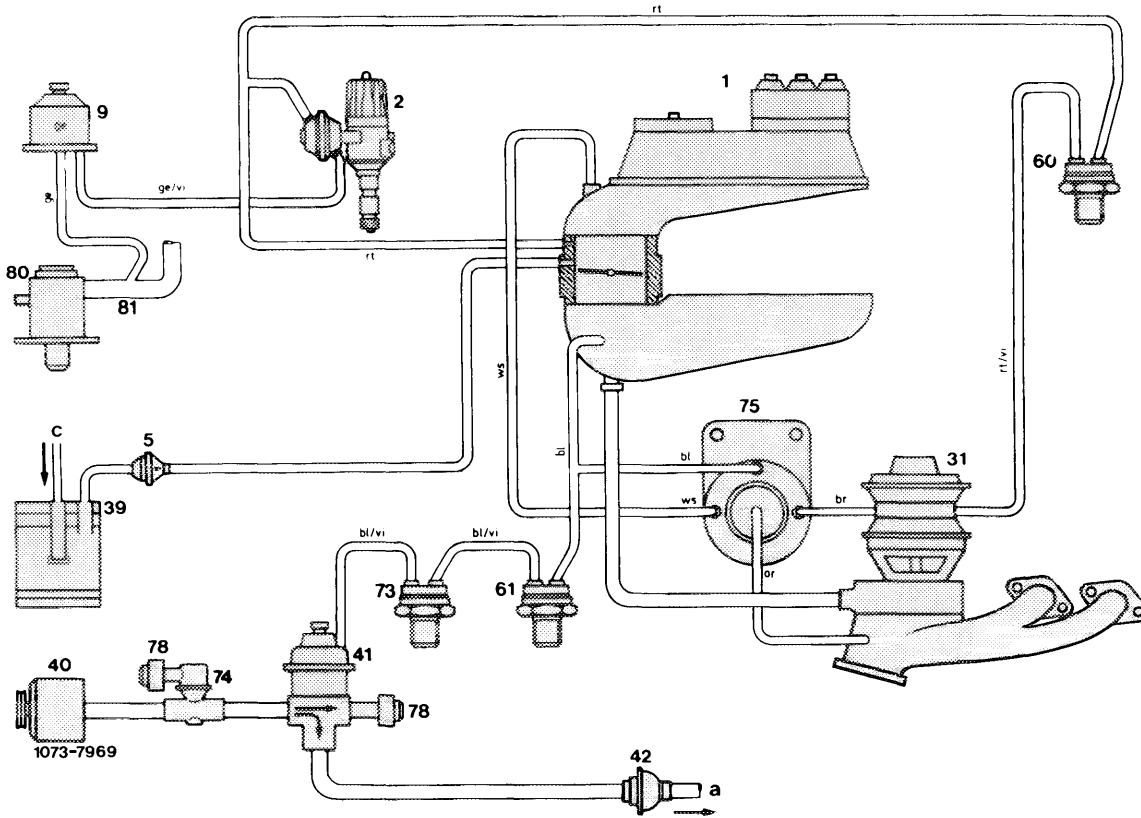

- | | | | |
|------------------------------|--------------------------|-----------------------------|------------------------|
| 1 Mixture controller | 39 Charcoal canister | 61 Thermovalve 17 °C | 80 Auxiliary air valve |
| 2 Ignition distributor | 40 Air pump | 73 Thermovalve 50 °C | 81 Contour hose |
| 5 Regenerating valve | 41 Air switch-over valve | 74 Pressure relief valve | a Air injection line |
| 9 Switch-over valve ignition | 42 Check valve | 75 Pressure transducer | cylinder head |
| 31 EGR valve | 60 Thermovalve 40 °C | 78 Air filter for silencing | c Connection tank vent |

Testing EGR

Pull brown vacuum line from EGR valve (31) and slowly increase idle speed.

Engine runs irregularly starting at approx. 1200/min or comes to a stop.

Engine operation continues without stop.

Test vacuum lines

Test layout of vacuum lines on transducer and intake pipe.

Note that connections on pressure transducer are identified with color rings. The plugged-on vacuum lines should have the same color.

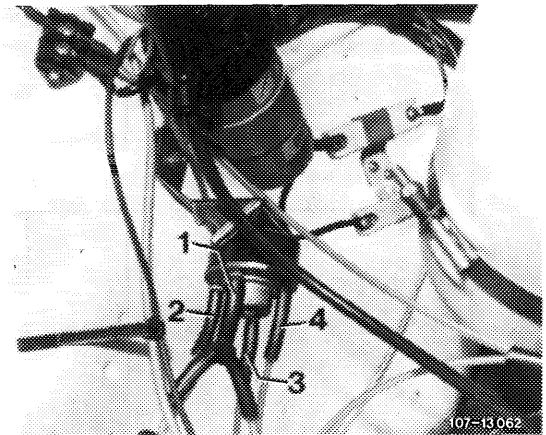

- 1 Connection intake pipe vacuum (blue)
- 2 Connection vent line (white)
- 3 Connection exhaust gas backpressure line (orange)
- 4 Connection vacuum control line to EGR valve (brown)

On black thermovalve 40 °C (60) the red vacuum line should be connected to diagonal connection, and the rubber hose to straight connection. Check all pertinent vacuum lines for leaks and blow out vacuum draw-off connections.

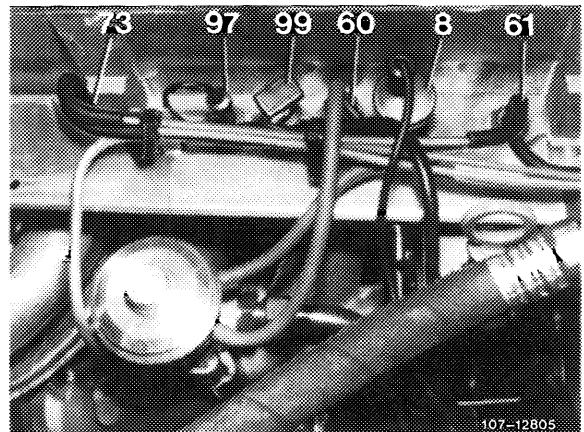

Test thermovalve 40 °C (60)

The thermovalve is identified by black plastic section and by the designation "50 AA 4" punched into metal section.

Pull-off vacuum hose at straight connection, keep engine running and accelerate.

Vacuum should be available at free connection.

When removing and installing thermovalve, make sure that the small connecting pipes are not damaged.

Test pressure transducer (75)

Run engine at idle. Pull-off brown vacuum line on EGR valve. Connect vacuum gauge or keep vacuum line closed with finger. Vacuum should be available at idle speed.

If there is no vacuum, renew pressure transducer.

Test EGR valve (31)

Run engine at idle speed. Pull-off both hoses on EGR valve.

Plug brown vacuum line to connection for red/purple vacuum line. Engine should run irregularly or come to a stop.

If operation of engine is not changing, renew EGR valve.

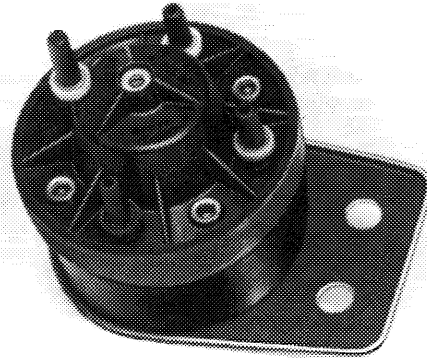

107-12314

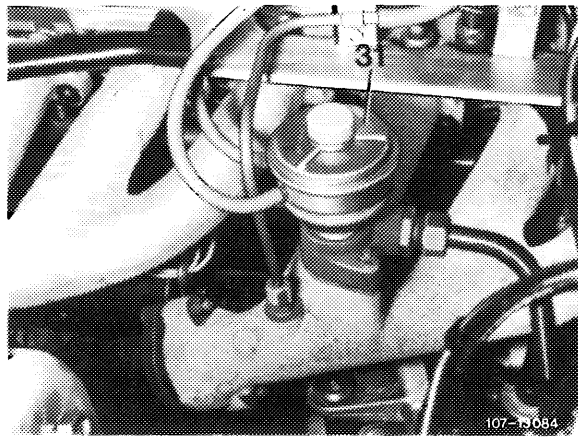

107-13084

Testing air injection

Connect CO measuring instrument and read exhaust gas emission value. Change vacuum hose from straight plug connection of thermo-valve (73) to straight plug connection of thermo-valve (61).

Exhaust gas value clearly decreasing.

Exhaust gas value not decreasing.

Test vacuum lines

The blue vacuum line from intake pipe should be connected to diagonal connection of thermo valve (61) by means of a distributor. The purple/blue vacuum line leads from straight connection of thermo valve (61) to diagonal connection of thermo valve (73) and from straight connection of thermo valve (73) to air switch-over valve (41).

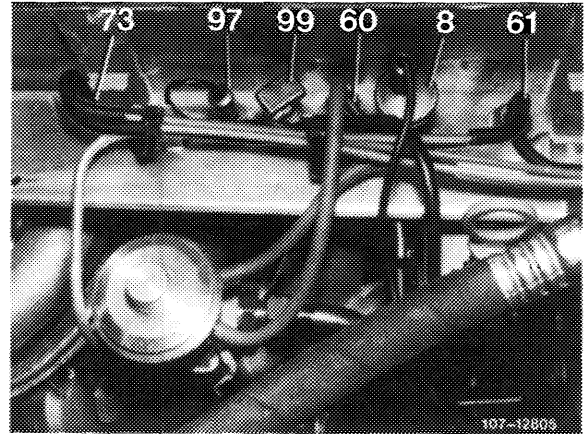

Test vacuum

Check at straight connection of thermo valve (61) for vacuum. If vacuum is available, renew air switch-over valve (41).

If there is no vacuum:

Pull-off blue vacuum line on thermo valve (61) and check for vacuum.

If vacuum is available:

Renew thermo valve (61).

If there is no vacuum:

Remove vacuum line to intake pipe and blow out with compressed air.

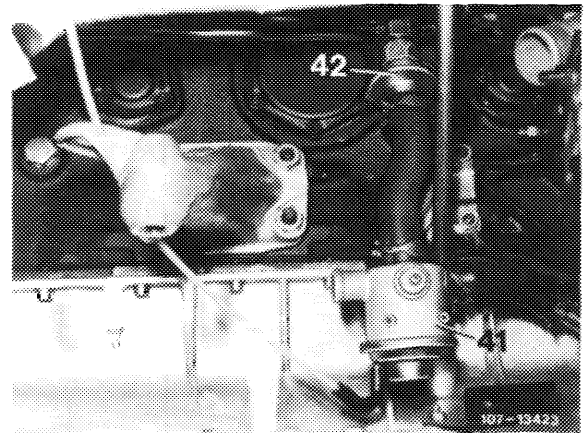

Test thermo valve (73)

If upon completion of the above jobs the exhaust gas value is still not decreasing, test thermo valve (73) for passage and renew, if required.

Below approx. 50 °C thermo valve is open, above approx. 50 °C valve is closed.

The thermo valve is identified by black plastic section with a green color dot and by the designation "50 AA 13" punched into metal section.

Note: Starting model year 1978 the identifying color is green, designation "50 AC 13".

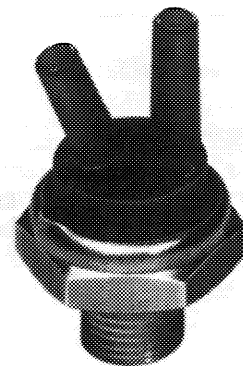

Testing fuel evaporation control system

Pull-off black plastic line (draw-off line) to throttle valve housing from charcoal canister and keep closed with finger or connect vacuum gauge.

Slowly increase engine speed to above approx. 2000/min.

No vacuum at idle.
Vacuum increasing
at increasing speed.

Vacuum not increasing
at increasing speed.

Model year 1977

Test draw-off hose

Draw-off hose must be plugged to throttle valve housing (arrow). Check hose for leaks and blow out connection on throttle valve housing.

Model year 1978/79

Test draw-off hose and regenerating valve (purge valve)

Draw-off hose should be plugged to throttle valve housing (arrow). Check hose for leaks and blow out connection on throttle valve housing.

If there is still no vacuum, pull-off draw-off hose in front of regenerating valve and repeat test.

If vacuum is available, renew regenerating valve (purge valve).

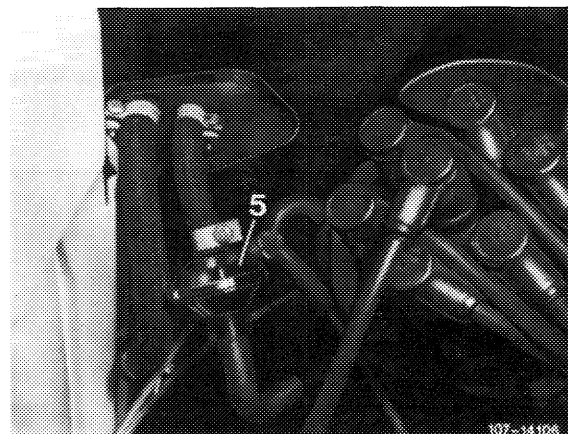
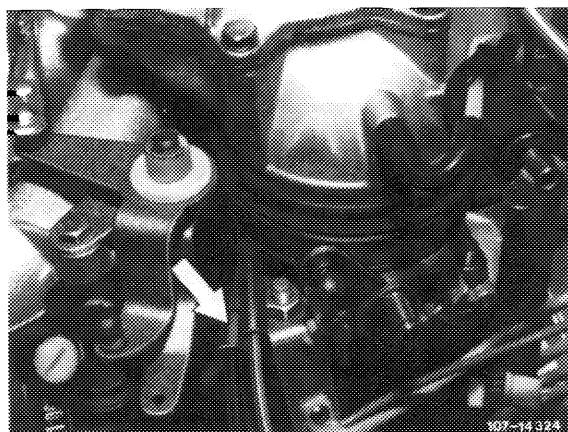

End of test