

Model year 1977/78/79

A. Federal version

### Removal

---

1 Loosen nuts of flange connections on exhaust manifold and unscrew.

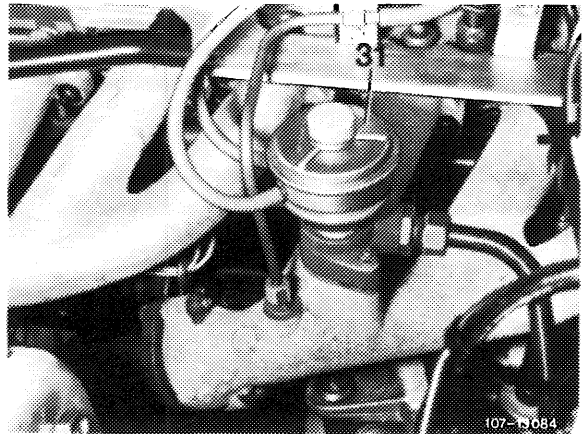

2 Remove heat shields.

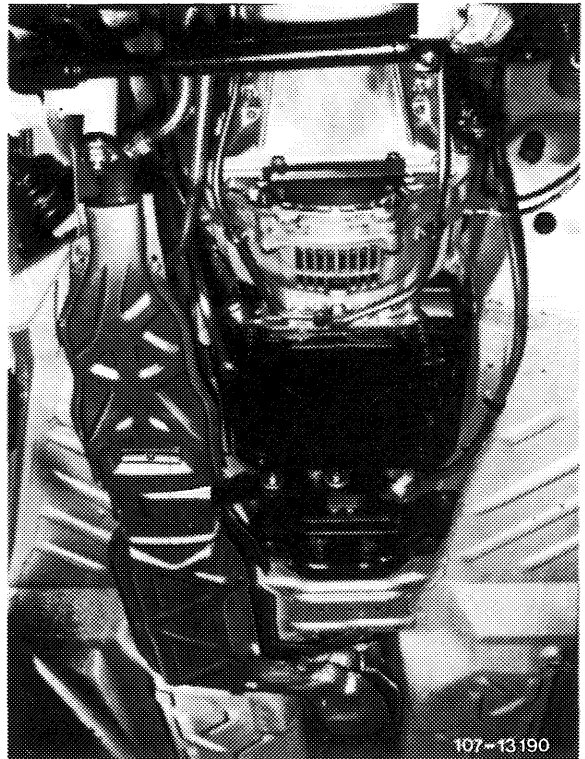

3 Remove lateral support on transmission suspension.

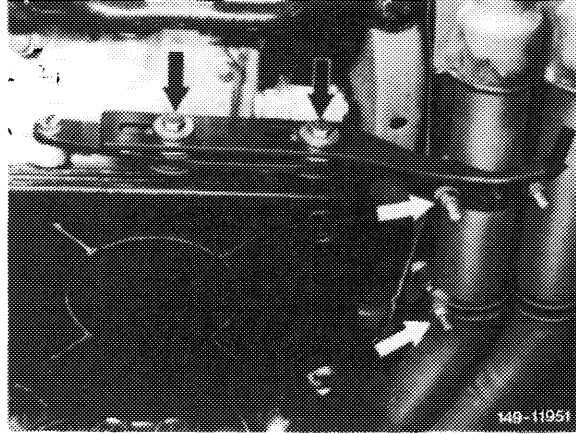

4 Remove rubber damper between catalyst and center muffler. Disconnect rubber rings on resonance damper and remove exhaust system in downward direction.

5 Loosen clamps of underfloor catalyst plug connections. Heat plug connections with a blow torch and remove underfloor catalyst.

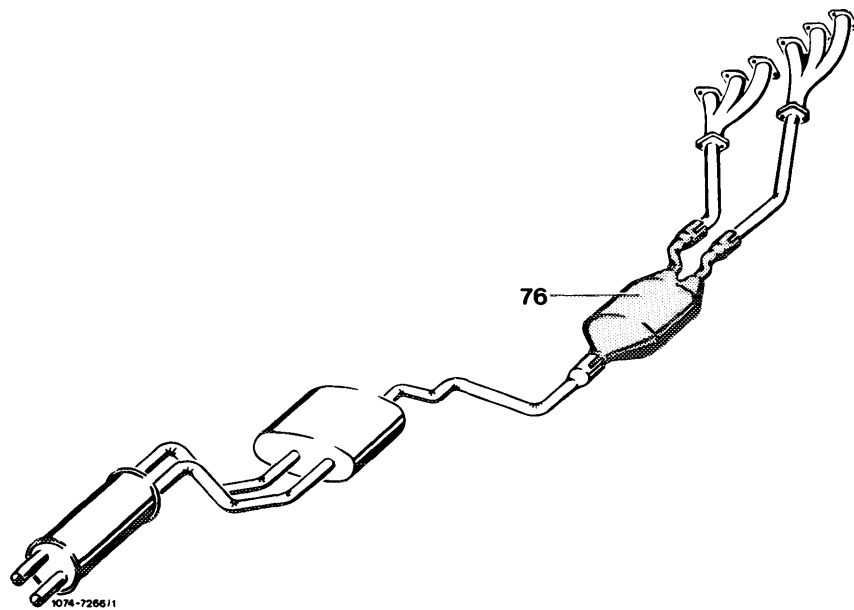
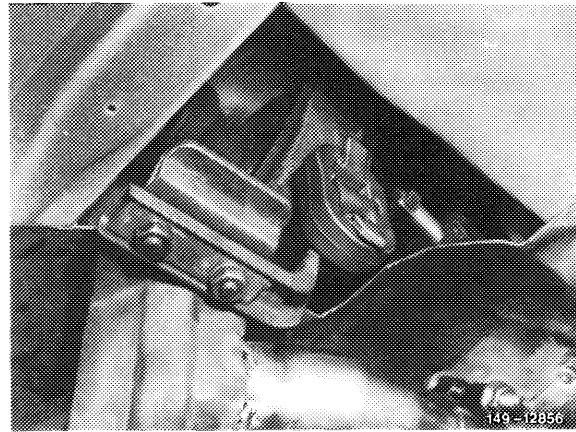

## Installation

---

6 Plug catalyst into exhaust system (renew self-locking hex nuts of clamps, as well as those of flange connections). Slightly tighten plug connections.

Install exhaust system and align.

For further installation proceed vice versa. Tightening torque of self-locking hex nuts (6) is 20 Nm (2 kpm).

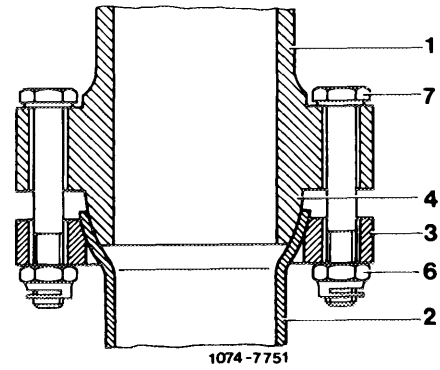

## B. California version

### Removal

---

1 Loosen nuts of flange connections on exhaust manifold and screw off.

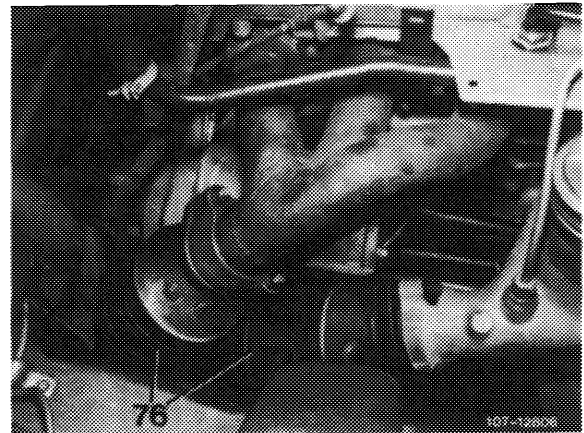

2 Remove heat shields.

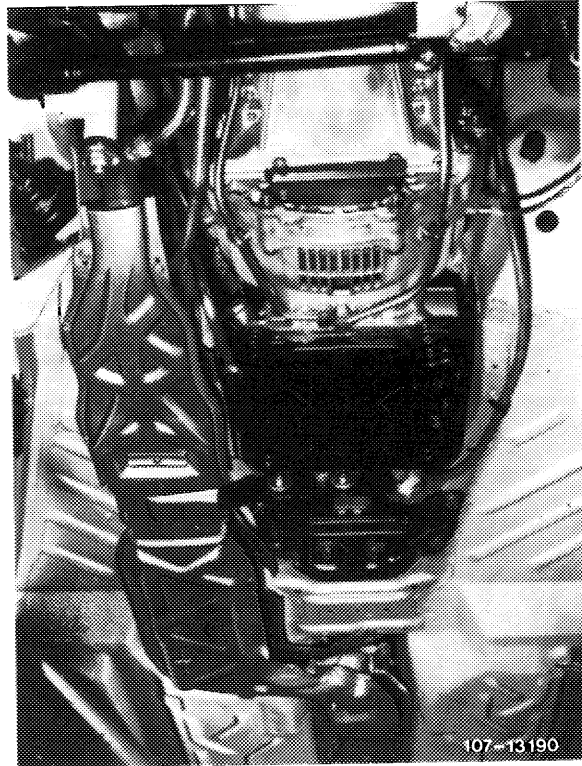

3 Unscrew air injection lines behind small catalyts.

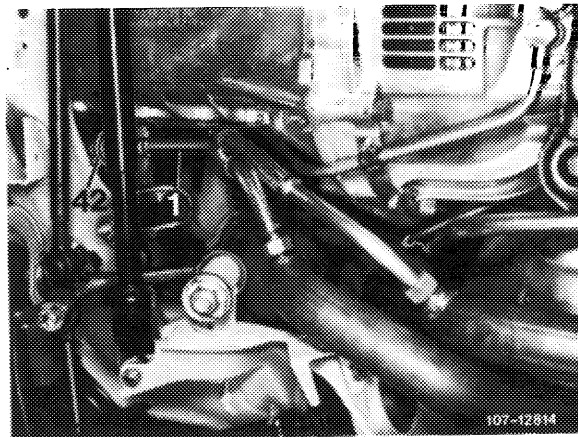

4 Disconnet lateral support on transmission suspension.

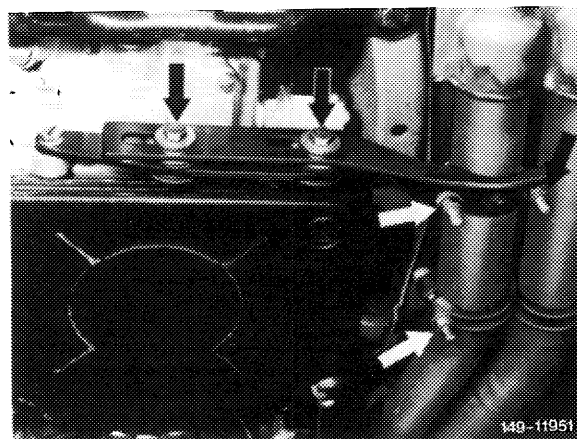

5 Remove rubber damper between catalyst and center muffler. Disconnect rubber rings on resonance damper and remove exhaust system in downward direction.

6 Loosen clamps of underfloor catalyst plug connections. Heat plug connections with a blow torch and remove front catalysts as well as underfloor catalyst.

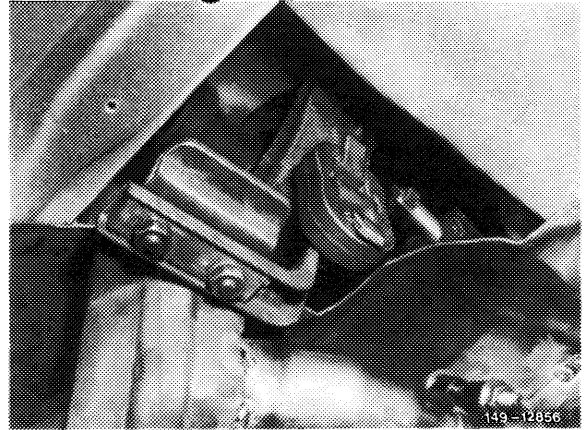

### Installation

7 Plug catalysts into exhaust system (renew self-locking hex nuts of clamps, as well as those of flange connections). Slightly tighten plug connections.

Install exhaust system and align.

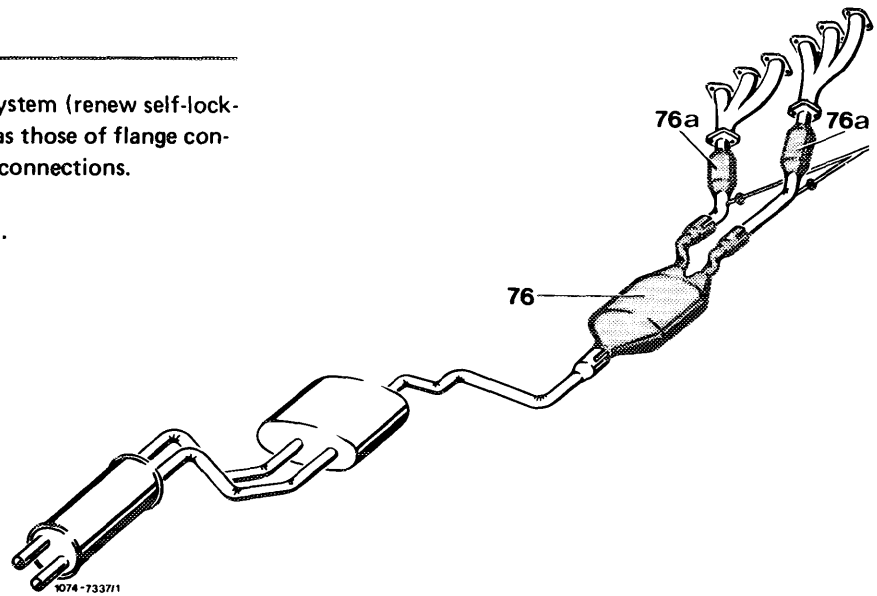

For further installation proceed vice versa. Tightening torque of self-locking hex nuts (6) is 20 Nm (2 kpm).

- 1 Exhaust manifold
- 2 Exhaust pipe
- 3 Flange
- 4 Cone connection
- 6 Self-locking hex nut
- 7 Hex screw

