

01–015 Checking cylinders for leaks

Data

Total pressure loss	max. 25 %
On valves and cylinder head gasket	max. 10 %
On pistons and piston rings	max. 20 %

Special tool

Socket 27 mm, 1/2'' square
for rotating engine



001 589 65 09 00

Conventional tool

Cylinder leak tester

e.g. made by Bosch EFAW 210
Made by SUN, CLT 228

Checking

- 1 Run engine up to operating temperature.
- 2 Unscrew spark plugs.
- 3 Remove radiator cap and add coolant.
- 4 Remove oil filler plug
- 5 Loosen rubber scoop on carburetor and pull off.
- 6 Connect cylinder leak tester to a compressed air line. Calibrate tester.

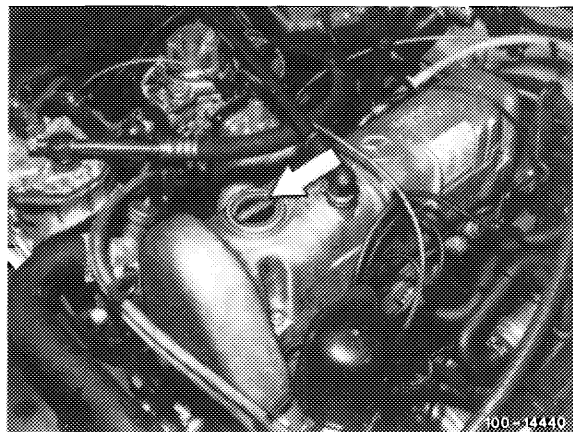

- 7 Set piston of 1st cylinder to ignition TDC.

For this purpose, turn engine on crankshaft by means of tool combination.

- 8 Set throttle valve to fully open.

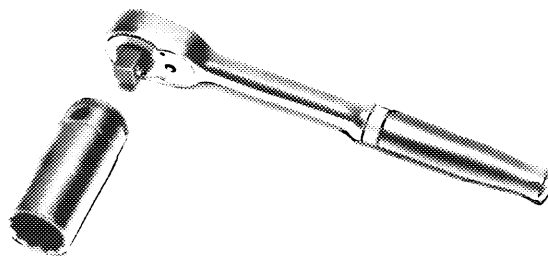

9 Screw connecting hose into 1st spark plug bore and couple to connecting hose of tester. Crankshaft should not rotate.

10 Read pressure loss on tester.

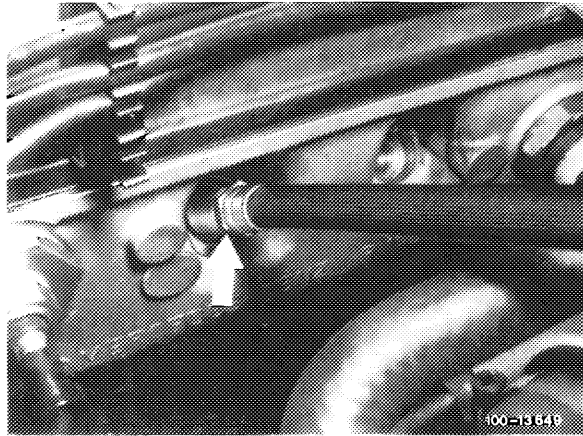

11 Check by listening whether pressure escapes via intake pipe, exhaust, oil filler cap, spark plug bore of adjacent cylinder or radiator cap.

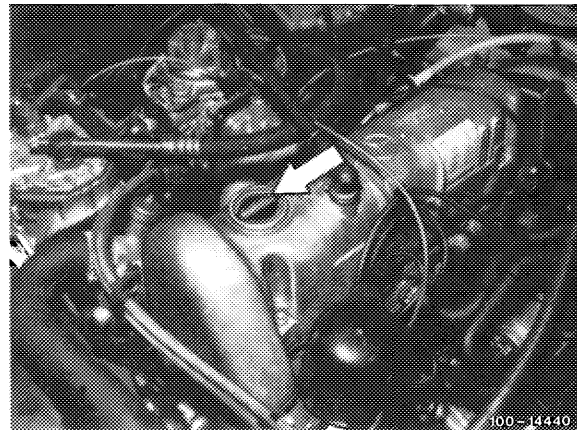

12 Check all cylinders in ignition sequence.

Note: The respective pistons are in TDC position when the markings shown on adjacent drawing are below TDC indicator on vibration damper.

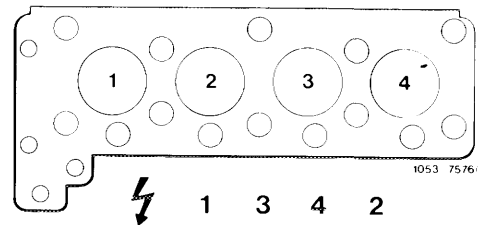

Note: There is the possibility that the piston ring gaps of individual pistons are directly one above the other, so that the test result will be misrepresented.

When in doubt, continue running vehicle and check cylinders for leaks once again later on.

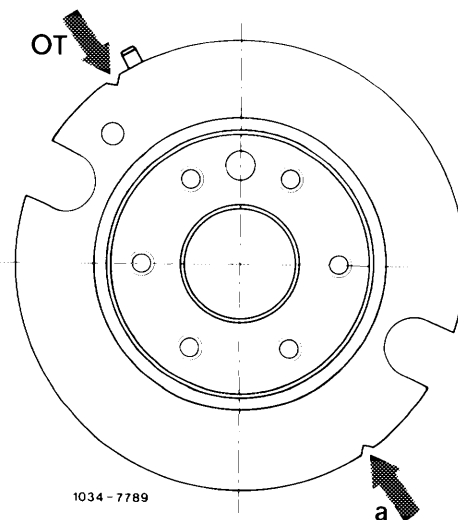

OT = TDC piston 1 and 2
a piston 2 and 3