

01—030 Removal and installation of engine (oil filling capacity)

Specified viscosity classes according to SAE during constant outside temperatures

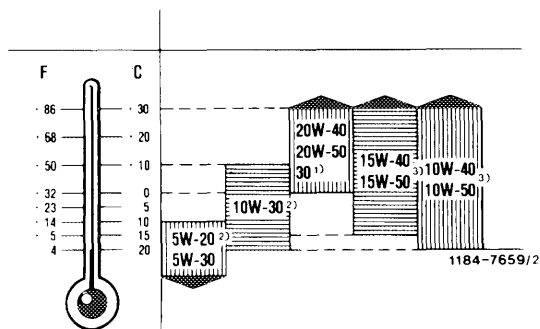

- 1) During constant outside temperature above +30°C (+86 °F) SAE 40 may be used.
- 2) For engine oils which are marked on pages 226.1 and 227.1 of the specifications for service products by footnote¹⁾, the following shall apply:
SAE 5 W—20 below +10 °C (+50 °F).
SAE 10 W—30 in moderate zones all the year over.
- 3) All-year oil.

Oil filling capacity in liters (for approved engine oil grades refer to specifications for service products)

Engine (total filling capacity during initial filling)	6.0
--	-----

Tightening torques		Nm	(kpm)
Oil drain plug to oil pan	M 26	50	(5)
	M 12	40	(4)
Fastening screw for oil filter lower half		40	(4)
Screws for engine carrier on engine mount front (model 123)	M 12	70	(7)
	M 10	40	(4)
Nut for engine stop on cross member (model 115)		90	(9)
Adjusting screw for front engine stop (model 123)		130	(13)
Adjusting screw for rear engine mount	Model 115	30	(3)
	Model 123	40	(4)

Special tools

Torque wrench handle with inserting ratchet 1/2" square, 25—130 Nm	001 589 66 21 00
Torque wrench handle with inserting ratchet 1/2" square, 40—200 Nm	001 589 67 21 00



Tester for cooling system and radiator cap

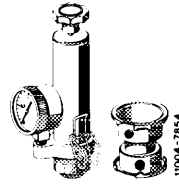

001 589 48 21 00

Double socket to radiator cap testing with tester



000 589 73 63 00

Radiator cap with hose for leak test

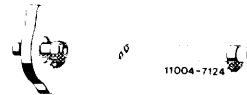

605 589 00 25 00

Allen-box wrench 14 x 17 mm



000 589 24 07 00

Syringe for removing oil

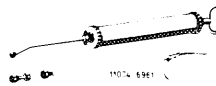

112 589 00 72 00

Conventional tool

Engine hoist (Motordirigent) No. 3180

Made by Bäcker, D-5630 Remscheid
Order no. 3178

Removal

- 1 On model 123, move engine hood into 90° position and engage lefthand detent (arrow).
- 2 Drain coolant.
- 3 Remove radiator.
- 4 On vehicles with air conditioning, remove refrigerant compressor together with connected lines and put aside. For this purpose, remove air filter on model 123.

If the refrigerant compressor is removed, drain air conditioning system (83-516).

- 5 On vehicles with level control, remove pressure oil pump together with connected lines. For this purpose, loosen only screws indicated by arrows.

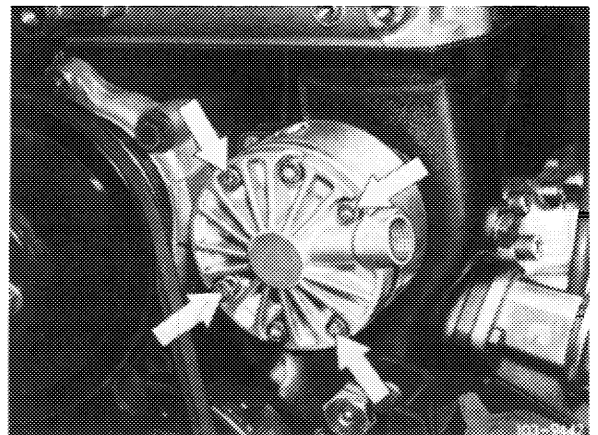
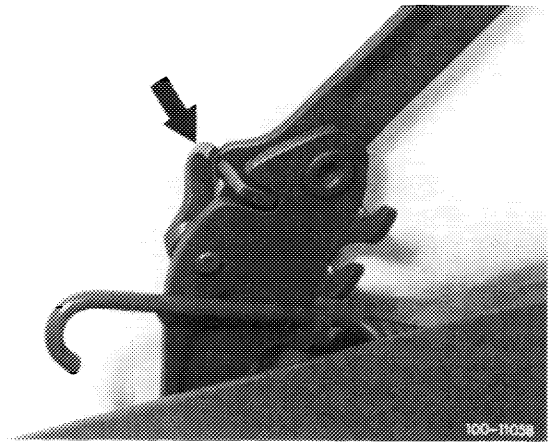

6 Draw oil from reservoir of powersteering pump and disconnect hose system.

7 Disconnect longitudinal regulating linkage.

8 Disconnect all cooling water, vacuum, oil, fuel and electric lines leading to engine.

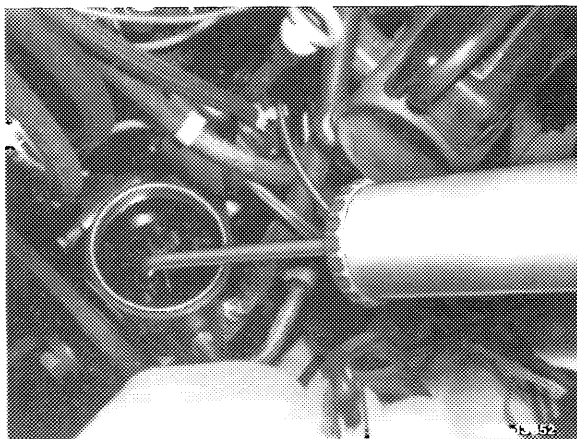

9 On model 123, pull cable for TDC transmitter from test socket.

For this purpose, unscrew test socket on holder.

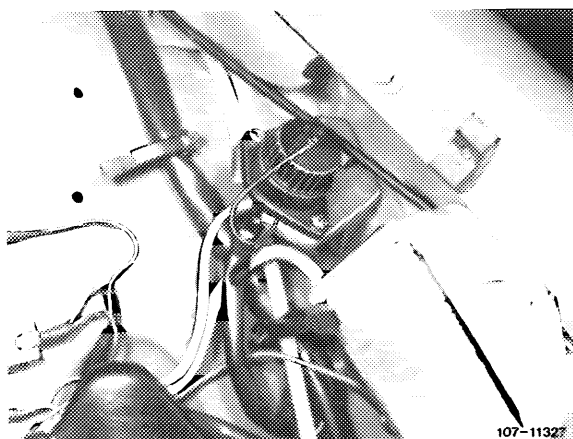

10 On model 115.017 and model 123 with automatic transmission, unscrew engine shock absorber on cross member.

Model 115.017

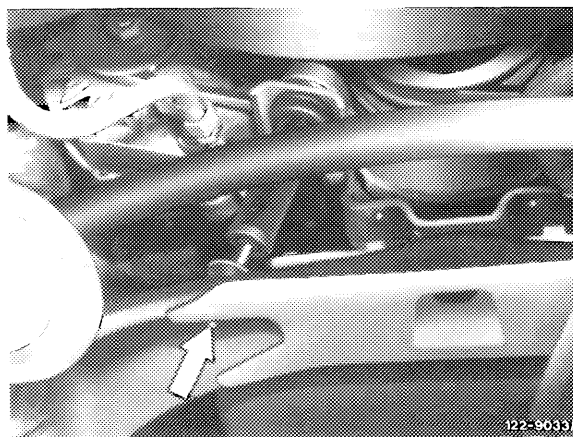

Model 123

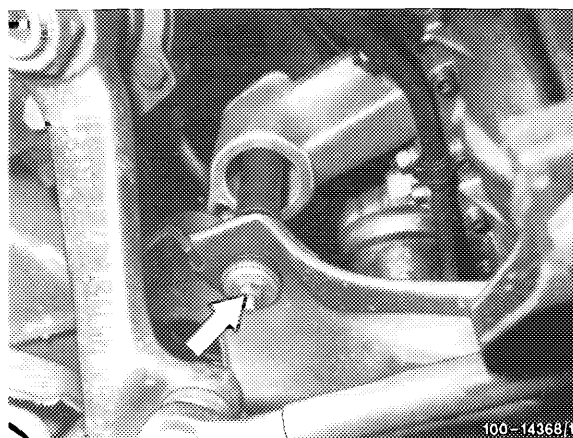

11 On all models (except model 115.017), unscrew engine stop.

For this purpose, on model 115.015, unscrew self-locking nut (32) and pull out adjusting screw.

On model 123, lift lock (30) and swivel away in lateral direction. Unscrew adjusting screw (31).

Model 115.015

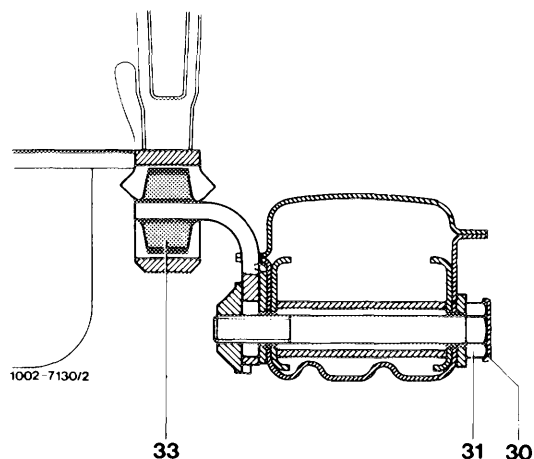
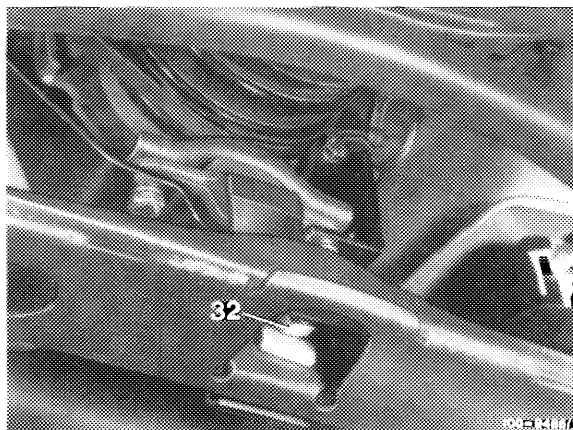

Model 123

12 Unscrew exhaust on exhaust manifold and on lateral support on transmission.

13 On model 115 with automatic transmission, unscrew steering damper on one side (arrow) and turn aside.

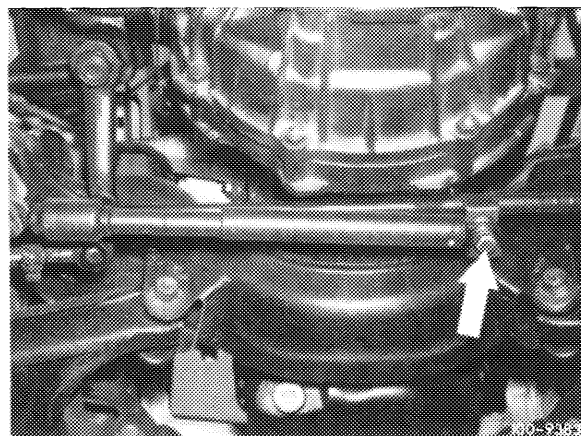

14 On model 123, unscrew screws for engine carrier on engine mount front from below, and on model 115 from above.

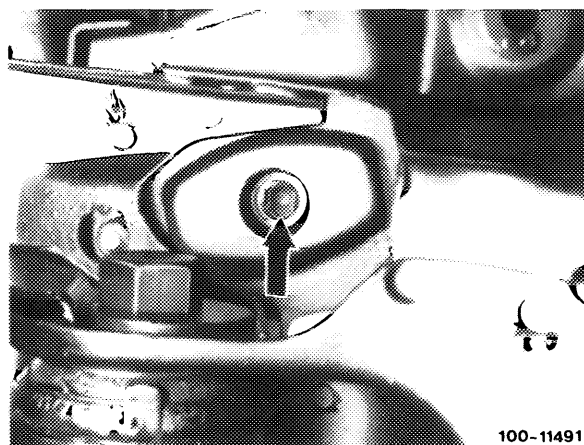

- 15 Unscrew universal shaft on transmission.
- 16 Loosen all connections and shift rods on transmission.
- 17 Remove rear engine carrier with engine mount.

- 18 Attach ropes of engine hoist to suspension eyes.

Attention!

On front suspension eye with two holes, attach rope at bottom hole only (arrow).

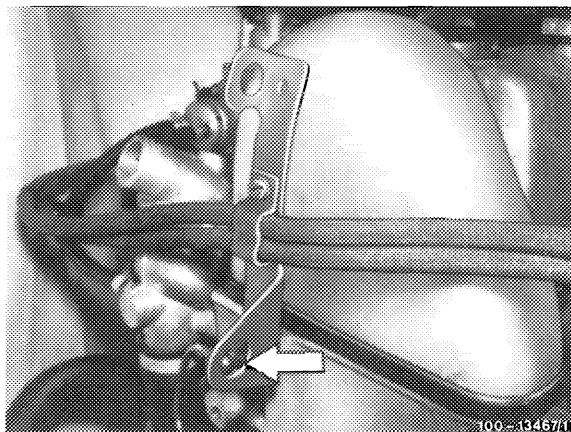

Front suspension eye
Model 123

On engines with two suspension eyes, the rope can be attached at bottom or at top (arrows).

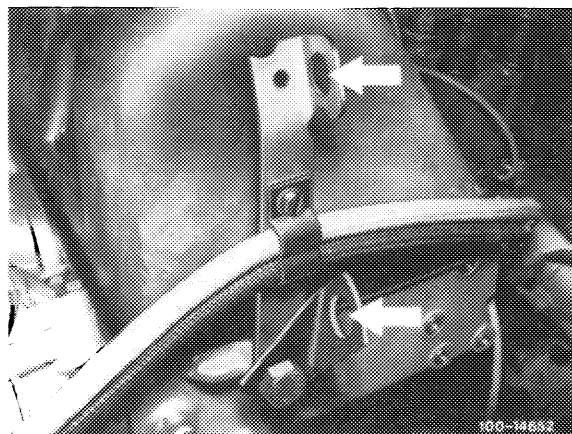

Front suspension eyes
Model 123

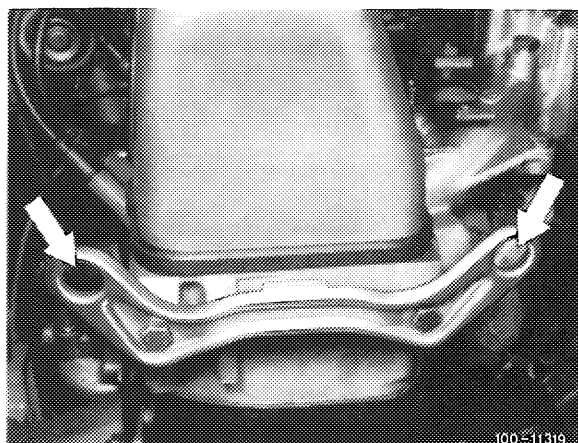

Rear suspension eyes
Model 123

19 Lift out engine with transmission in a diagonal position of approx. 45°.

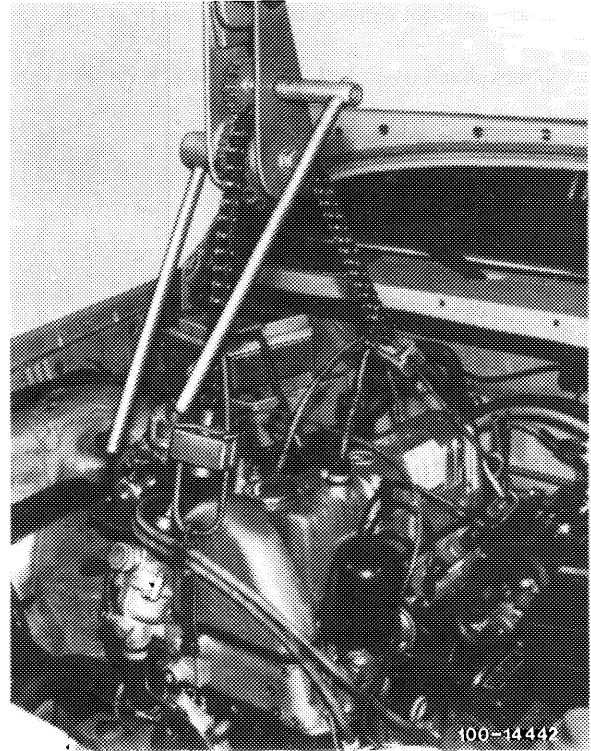

Installation

Attention!

When installing a new engine following previous bearing damage, flush oil cooler and oil hoses. Clean oil filter housing.

20 Check engine mounts, engine shock absorbers, oil and fuel hoses and replace, if required.

21 Prior to flanging-on of manual transmission, check radial ball bearing in crankshaft and throwout of clutch and renew, if required.

22 Install engine and connect.

23 Screw-on universal shaft and adjust (41-020).

24 Adjust engine stop (22-220).

25 Check all drain plugs for tight seat.

26 Fill-in oil and coolant (20-010).

27 Pressure-test cooling system with tester.

Check coolant for antifreeze (20-010).

- 28 Clean air filter element and replace if required.
- 29 Check dwell angle and firing point (15–500).
- 30 Adjust idle speed (07.2–100).