

Self-made tool

Mandrel for knocking-in steel ball

refer to fig. item 10

Note

Starting with the chassis end numbers named below, the main oil ducts in cylinder crankcases are closed at transmission end by means of a steel ball (15 mm dia.)

Model	Chassis end no.
115.015	315 555
115.017	087 250
123.020	011 837
123.023	019 180
123.043	Start of series
123.083	Start of series

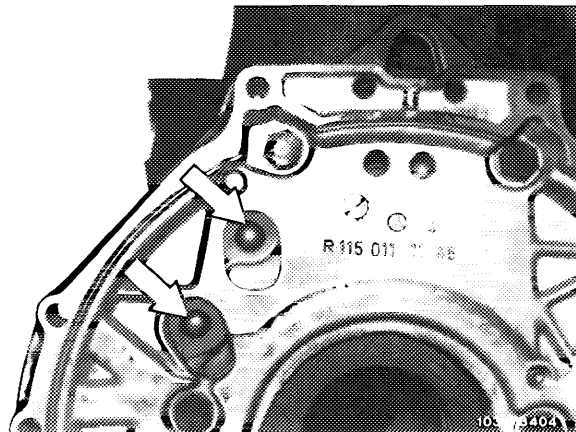

During engine repairs, the steel balls must be knocked out to clean main oil ducts.

Undamaged steel balls can be used several times without refinishing ball seat.

Replace damaged steel balls.

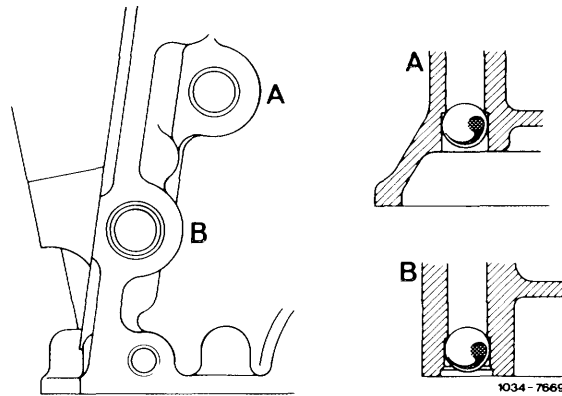

In case of leaks, adjust by means of knocking-in mandrel by approx. 1 mm (dimension preset on knocking-in mandrel).

If then the leaks should not be eliminated, knock out affected steel ball and replace through locking screw M 16 x 1.5, part No. 000 990 47 12.

For this purpose, cut thread M 16 x 1.5, 100 mm deep.

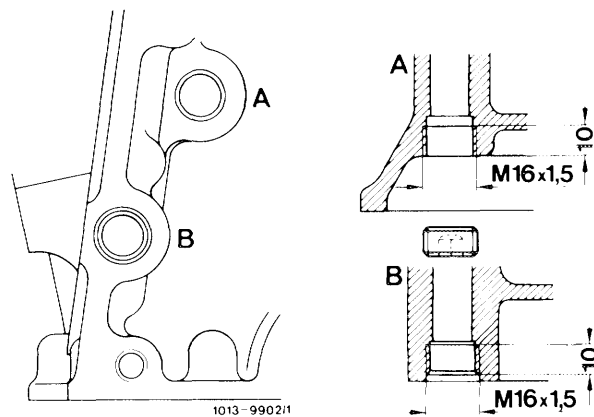

Thoroughly clean oil duct from chips.

Cover locking screw M 16 x 1.5 with sealing glue, part No. 002 989 94 71 and screw in.

Knocking out steel ball in upper main oil duct

- 1 Remove transmission and flywheel (03–410).
- 2 Remove radiator (20–420).
- 3 Unscrew TDC transmitter (3).

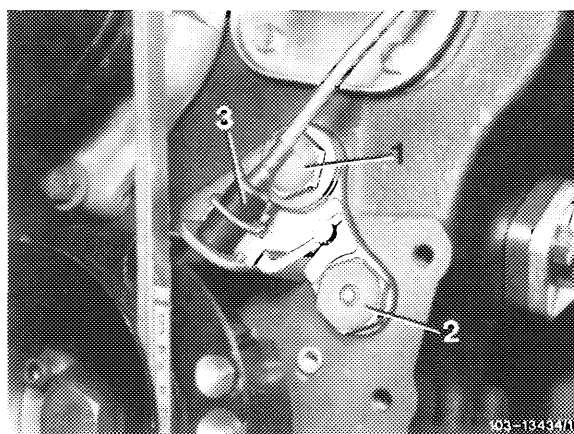

- 4 Unscrew closing plug (1) and remove adjustment indicator.
- 5 Unscrew oil pressure relief valve.
- 6 Lock out ball from the front with a round rod (13 mm dia.) approx. 850 mm long (fig. item 8).

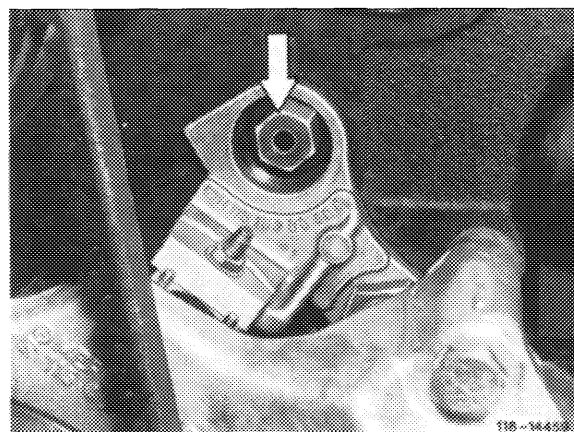

Knocking out steel ball in lower main oil duct

- 1 Remove transmission and flywheel (03–410).
- 2 Remove radiator (20–420).
- 3 On model 123 with power steering, remove aluminium carrier of power steering pump (arrow).

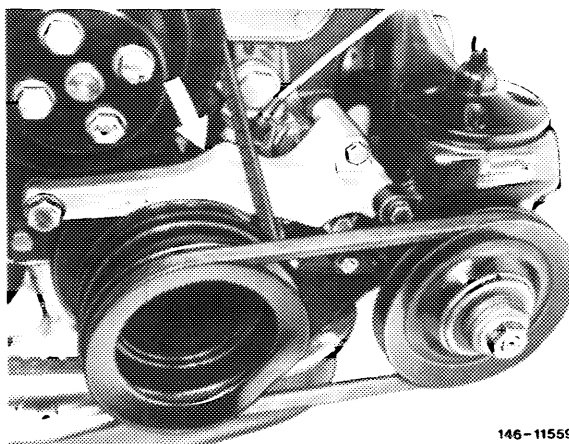

Note: Not applicable for (AUS) (J) (S) and (USA) starting 1977.

- 4 Unscrew closing plug (2).
- 5 Remove oil pump (18–210).
- 6 Remove slide rail (05–340).
- 7 Tilt engine slightly toward the rear.

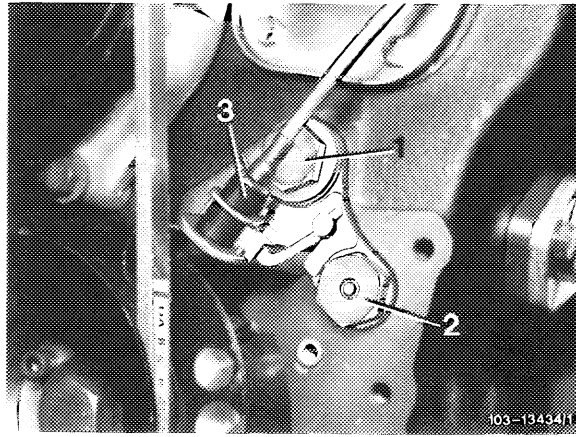

8 Knock out ball from the front by means of a round rod (13 mm dia.), approx. 850 mm long.

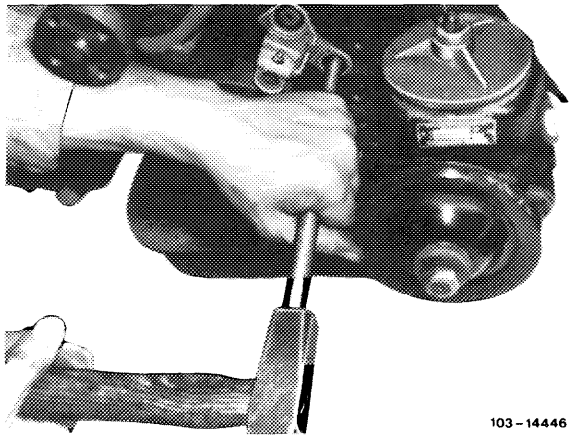

Knocking steel ball into upper and lower main oil duct

- 9 Thoroughly clean bore in pressing-in range of ball.
- 10 Coat spherical cup on self-made mandrel with grease and place steel ball into cup.

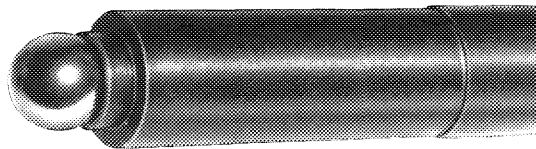

103-13 405

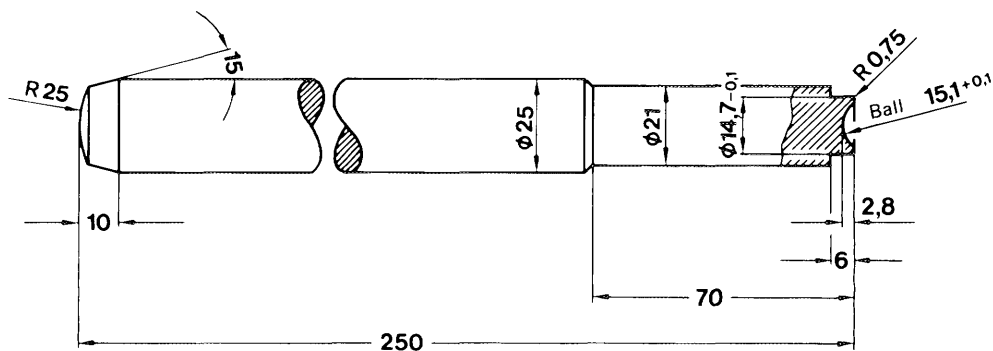

11003-7473

Knocking-in mandrel
Material: C 45

11 Position steel ball by means of mandrel and knock in up to stop on mandrel.

12 Mount all removed parts.

13 Run engine warm and check for leaks.

