

## 01–220 Installation and centering of intermediate flange

---

### Data

Vertical runout of intermediate flange	max. 0.10
--	-----------

### Tightening torques

	Nm	(kpm)
Fastening screws for intermediate flange	50	(5)
Necked-down screw for driven plate and flywheel	Initial torque	40 (4)
	Angle of rotation torque	90–100°

### Special tool

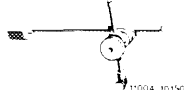
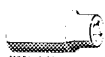
Dial gauge holder (2 each required)		363 589 02 21 00
Socket 27 mm, 1/2" square for turning the engine		001 589 65 09 00

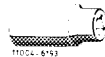
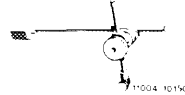

### Self-made tool

Threaded bolt	refer to fig. item 3
---------------	----------------------

### Note

---

A new intermediate flange must be centered.

For reasons of standardization with engine 110 in model 126, intermediate flanges with two additional bores (arrows) have been installed.

The bores are intended for transmissions with centering of set pins.

It is possible to mount these intermediate flanges on the previous engines as well.

Previous version

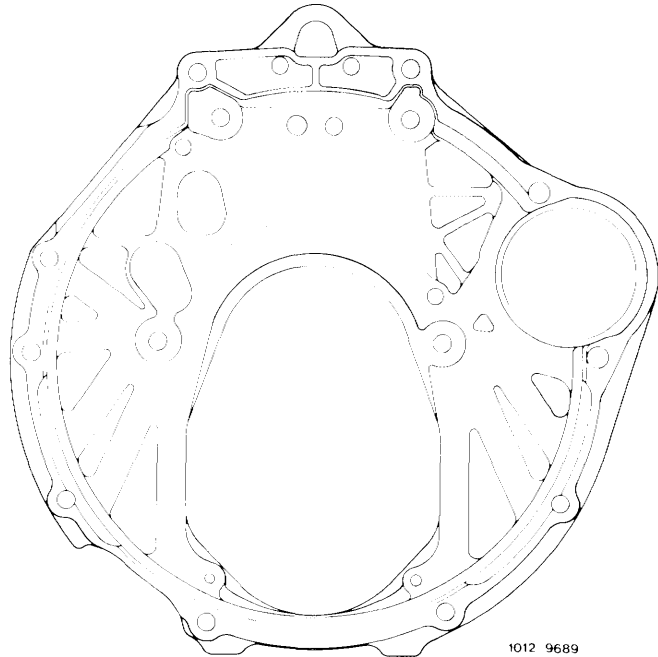

1012 9689

**Start of series: February 1980**

Model	Engine	Engine end No.		Chassis end No.
		manual transmission	automatic transmission	
123.020	115.938	104 711	024 877	141 564
	115.939	012 168	000 637	
123.000				178 623
123.023				
	115.954	134 370	069 490	
123.043				017 978
123.083				006 415

Present version

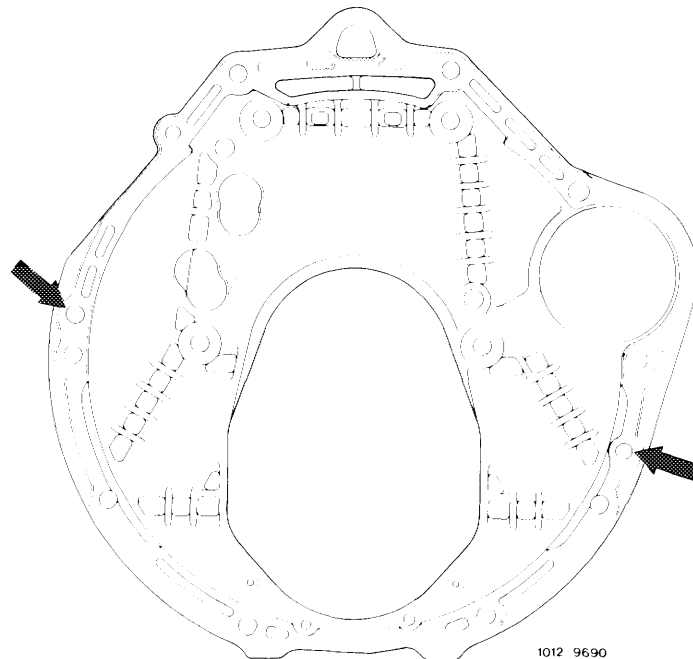

1012 9690

**Spare parts**

Designation	Previous part No.	Present part No.
Intermediate flange	115 011 15 45	615 011 02 45

**Installing and centering**

- 1 Insert intermediate flange into set pins of cylinder crankcase.
- 2 Slightly tighten the four fastening screws.

3 Screw threaded bolt (self-made) into crankshaft and counterlock with hex. nut.

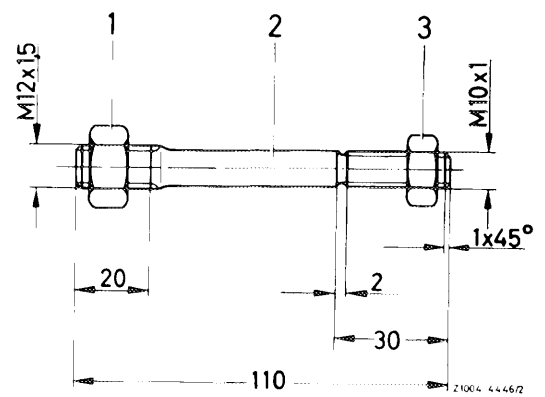

4 Attach dial gauge holder with dial gauge to threaded bolt.

5 Position feeler pin against OD of round center.

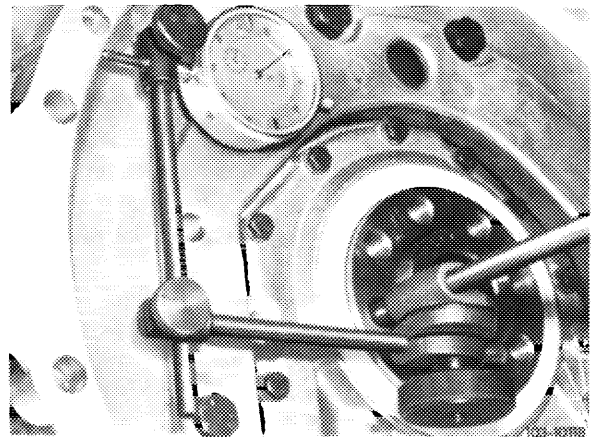

Shown on engine 116

6 Turn crankshaft with tool combination and measure vertical runout. Vertical runout should not exceed max. 0.10.

**Note:** When turning crankshaft, make sure that feeler pin of dial gauge is not getting stuck.

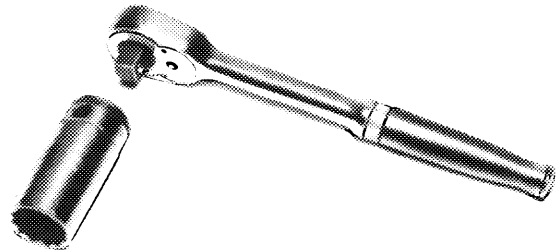

R 100/6498

7 Correct vertical runout by means of light blows against intermediate flange.

8 Tighten fastening screws.

**Note:** If the vertical runout is higher than 0.10 mm, remove intermediate flange.

9 Drill both fitted bores in intermediate flange to 12.1 mm

10 Repeat item 1–8.