

01-415 Removal and installation of cylinder head

Valve clearance	with engine cold (approx. 20 °C)	with engine warm (approx. 60 °C + 15 °C)
Intake	0.10 ¹⁾	0.15 ¹⁾
Exhaust	0.20	0.25

¹⁾ 0.05 mm higher during lasting outside temperatures below -20 °C.

Timings at 2 mm valve lift

Engines	Camshaft code No. ¹⁾	Intake valve opens after TDC	closes after BDC	Exhaust valve opens before BDC	closes before TDC
115.923/926/938					
115.939 and 115.951/954 low compression	05	14°	20°	22°	12°
115.951/954	13	14°	27°	36.5°	18.5°



(AUS) starting 1977, **(J)** and **(S)** starting 1976, **(USA)** starting 1974

115.951/954	05	14°	20°	22°	12°
-------------	----	-----	-----	-----	-----

¹⁾ The camshaft code No. is punched into rear end of camshaft.

Tightening torques		Nm	Nm	
bolts		M 10 (item 11-14)	M 12 (item 1-10)	
Cylinder head bolts	with engine cold	step 1	30	40
		step 2	55	70
		setting time	10 min	
		step 3	55	110
Nuts for cylinder head cover		15		
Necked-down bolt for camshaft gear (sprocket)		80		

Special tools

Socket 27 mm, 1/2" square, for rotating engine		001 589 65 09 00
Allen socket for cylinder head bolts 10 mm, 1/2" square, 140 mm long		000 589 05 07 00
Allen socket for cylinder head bolts 8 mm, 1/2" square, 130 mm long		000 589 33 07 00

Allen wrench for hex. socket screws
6 mm, 440 mm long

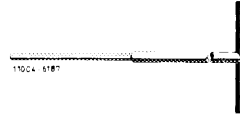

116 589 03 07 00

Impact puller for slide rail bearing bolt
(basic unit)

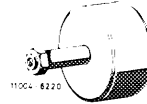

116 589 20 33 00

Threaded bolt for impact puller M 6, 50 mm long



116 589 01 34 00

Threaded bolt for impact puller M 6, 150 mm long



116 589 02 34 00

Contact handle for rotating engine
(component of compression pressure
recorder 001 589 46 21 00)

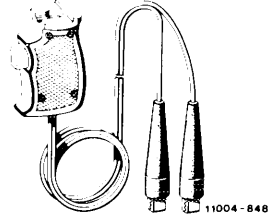

001 589 46 21 08

Conventional tool

Engine hoist (Motordirigent) No. 3180

e.g. made by Bäcker,
D-5630 Remscheid, Herderstr.

Note

Remove cylinder head only from cooled-down engine.
Remove together with exhaust manifold and intake
pipe.

Available cylinder gaskets for these engines require no
retightening. As a result, no retightening of cylinder
head bolts is required during first inspection (1000–
1500 km).

The cylinder head (arrows) of engine 115.954 rein-
forced in range of intake valve seat rings is not intend-
ed for installation in engine 115.951, since in such a
case compression would be unduly increased (also
refer to 03-316).

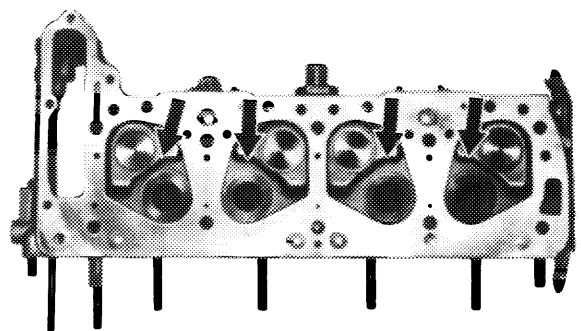

On the other hand, the intake valves with tapered cavity for reinforced cylinder head may also be installed at bottom of valve disc of engine 115.951.

The cylinder head low compression version approved for both engines 115.951 and 115.954 has been replaced on engine 115.954 starting with chassis end No. named below by cylinder head of engine 115.954 with normal compression (reinforced in range of intake valve).

To avoid inadmissible increase of compression, the pistons were modified (also refer to 03-316).

The low compression cylinder heads may be interchanged only in combination with pertinent pistons.

On engine 115.954 for (AUS), (J), (S) and (USA), the cylinder head used up to now is again intalled.

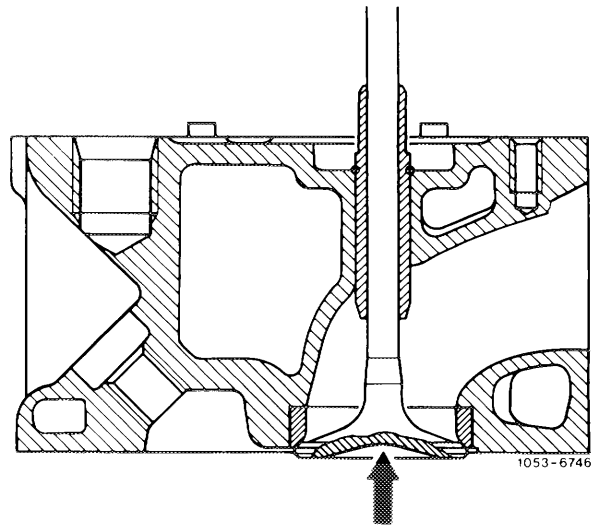

Model	Chassis end No.
123.023	083 266
123.043	003 801

In addition, starting with the chassis end numbers named below, the intake and exhaust ducts on reinforced cylinder head will be optimized.

Model	Chassis end No.
123.020	061 809
123.023	048 835
123.043	000 130
123.083	start of series

Removal

- 1 Completely drain coolant.

Drain plug on cylinder crankcase

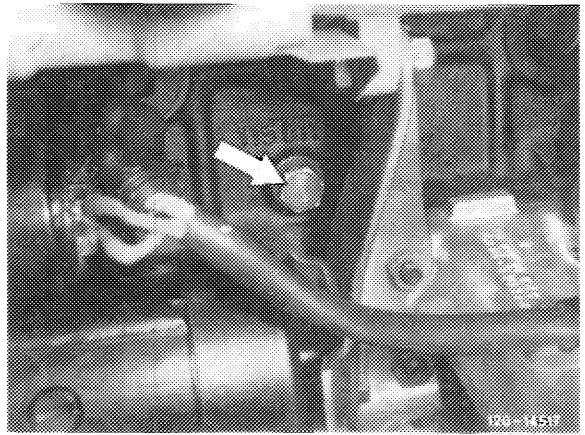

- 2 On model 123, move engine hood into 90° position and engage lefthand locking lever (arrow).

- 3 On vehicles with air conditioning, remove refrigerant compressor with carrier and connected lines and put aside.

For this purpose, completely remove air filter top on engines 115.923/926 and 951, and complete air filter on engines 115.938/939 and 115.954.

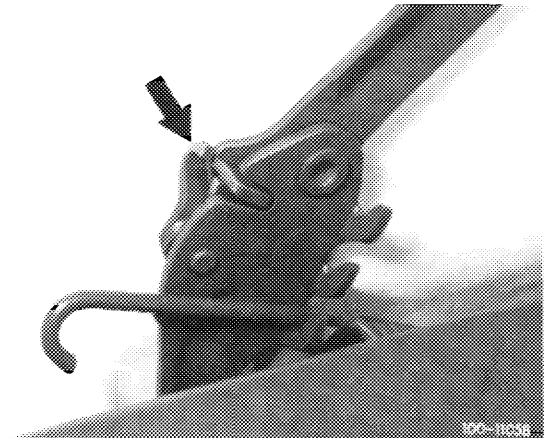

- 4 Disconnect all electrical connections, hot water, fuel and vacuum lines connected to cylinder head and intake pipe or carburetor.

- 5 Disconnect regulating linkage.

- 6 Unscrew oil dipstick guide tube for automatic transmission at intake pipe (arrow).

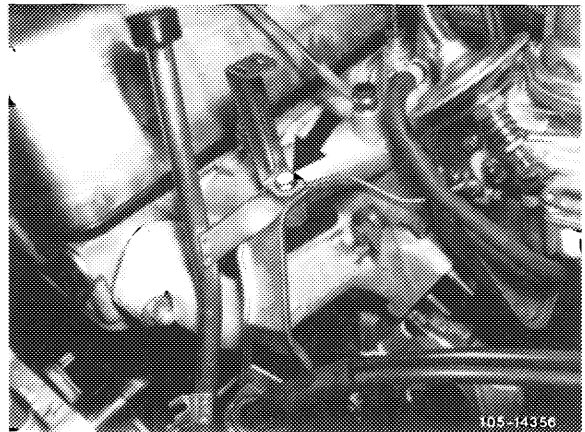

- 7 On (USA) 1974/75, remove vacuum pump with dolder.

- 8 On (USA) 1975/76 and (J) 1976, loosen both supporting holders of catalyst and starter cable on intake intake pipe.

9 On (J) , (S) starting 1976, (AUS) starting 1977 and (USA) starting 1974, disconnect air injection line (arrow).

10 Remove cylinder head cover.

11 Unscrew exhaust on exhaust manifold and loosen on transmission holder.

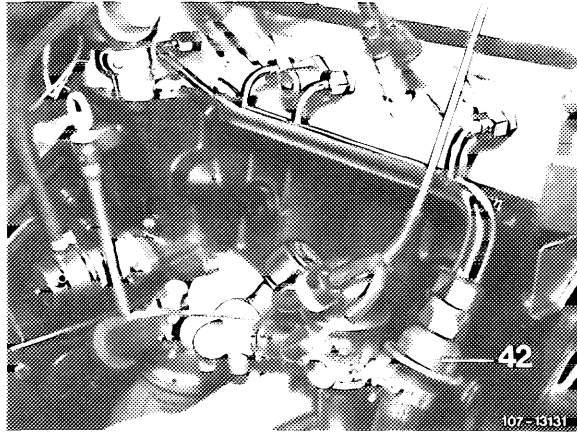

12 Unscrew exhaust manifold support on manifold (arrow).

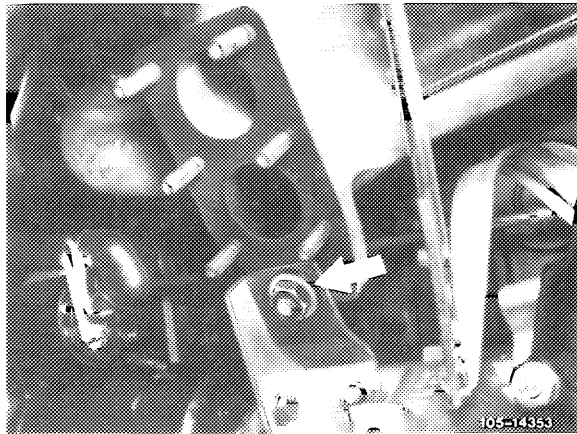

(AUS) starting 1977; (J) , (S) and (USA) starting 1976

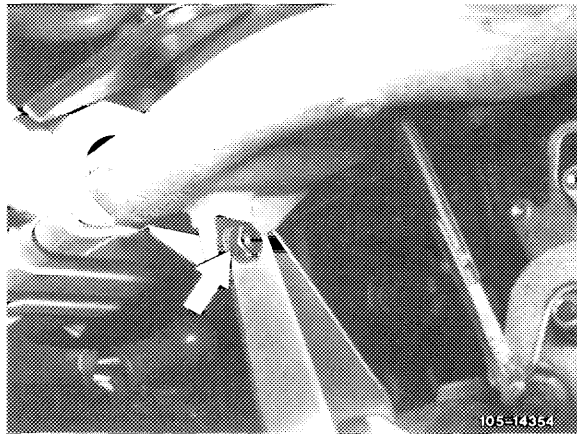

13 Loosen hose between thermostat housing and water pump top (arrow).

14 Unscrew bleed line between water pump and cylinder head on cylinder head.

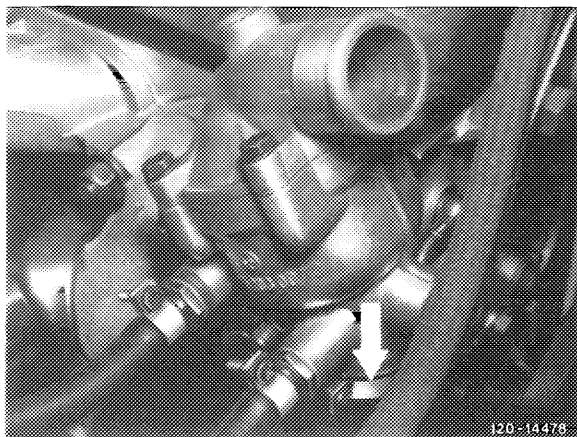

15 Set engine to ignition TDC of 1st cylinder. For this purpose, rotate engine on crankshaft by means of tool combination.

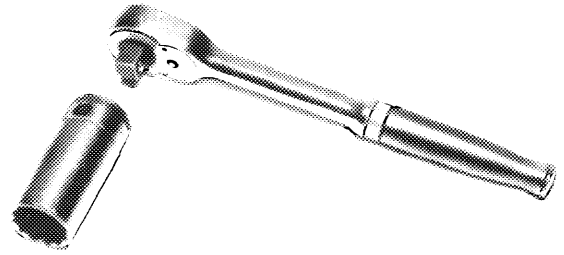

R 100/6498

16 Mark camshaft sprocket and timing chain in relation to each other.

17 Remove ignition distributor.

18 Remove inner slide rail (05—340).

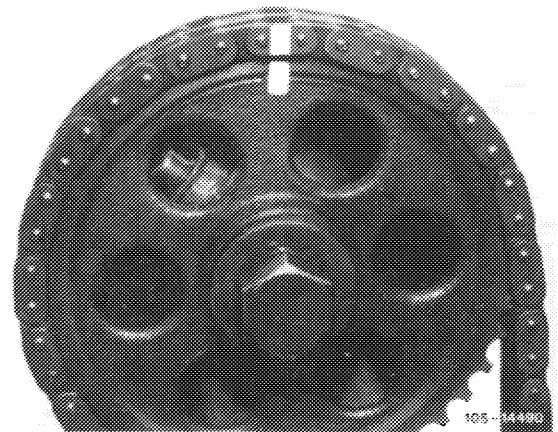

19 On engine 115.923/926/951 with tension chain version (A), remove chain tensioner.

On engines with light alloy tensioning rail (B), push back thrust bolt of chain tensioner.

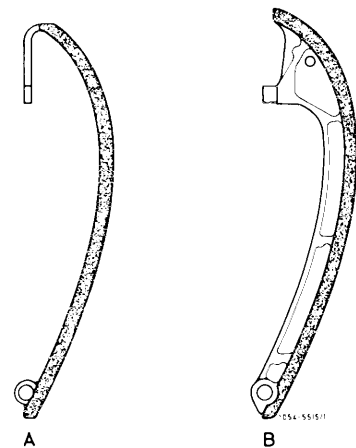

20 Remove camshaft sprocket. For loosening necked-down bolt of camshaft sprocket, apply counterhold with a screw driver or steel pin, loosen holder for fuel lines and swivel sideways.

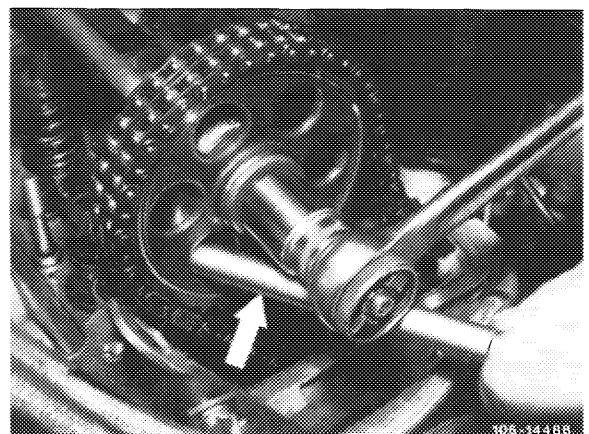

21 Loosen cylinder head bolts in vice versa sequence of tightening diagram by means of Allen socket and screw out.

Screw out M 8 bolts with Allen wrench 6 mm, 440 mm long.

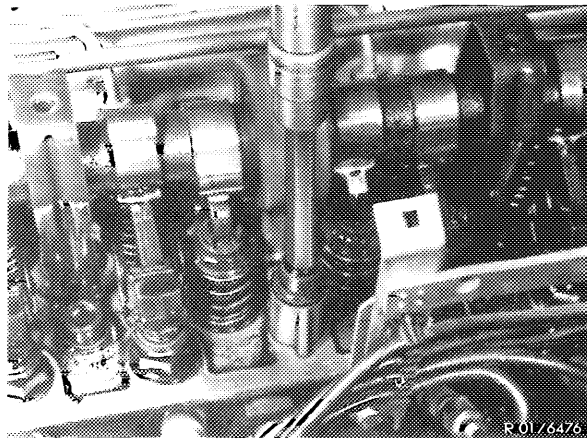
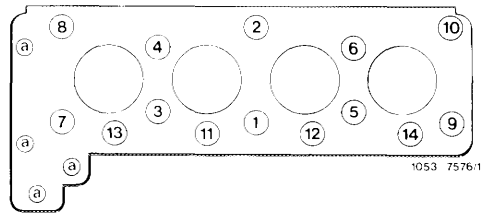

Allen socket 10 mm

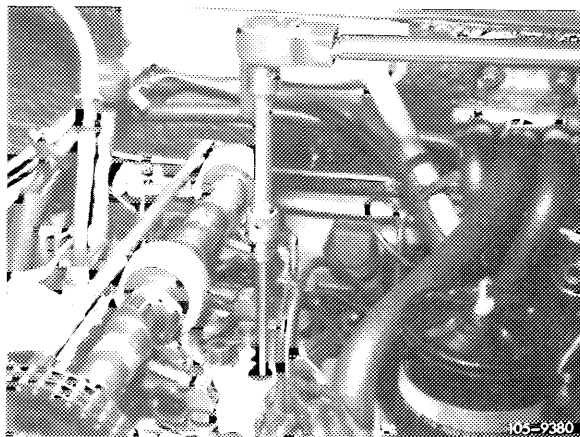

Allen socket 8 mm

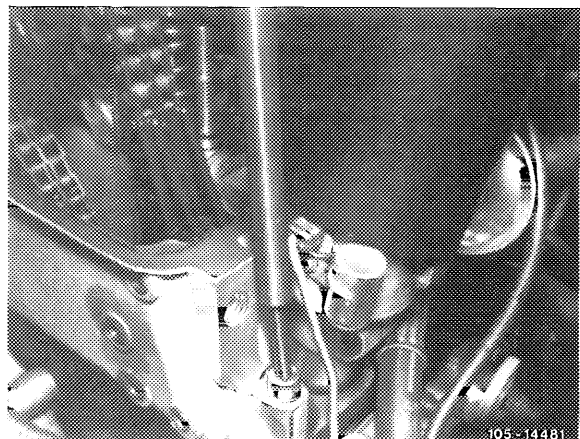

Allen wrench 6 mm, 440 mm long

22 On model 123, attach ropes of engine hoist to suspension eyes.

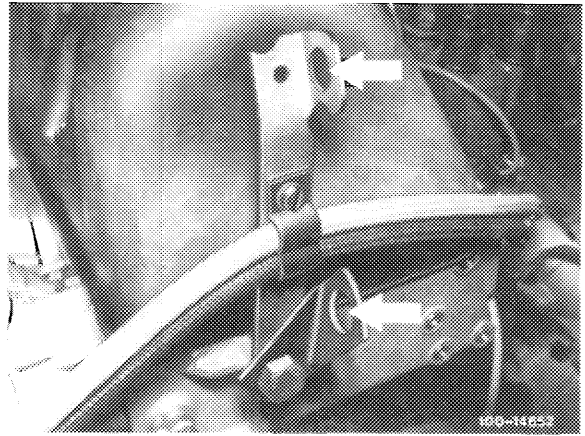

Front suspension eye

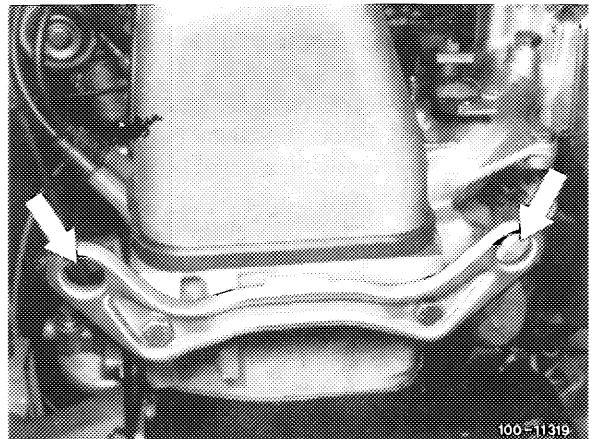

Rear suspension eye

23 Lift cylinder head with engine hoist and a crane vertically in upward direction, while pushing tensioning rail toward center of engine.

Note: On model 115, lift cylinder head manually.

24 Clean cylinder head and cylinder crankcase part-surface wall.

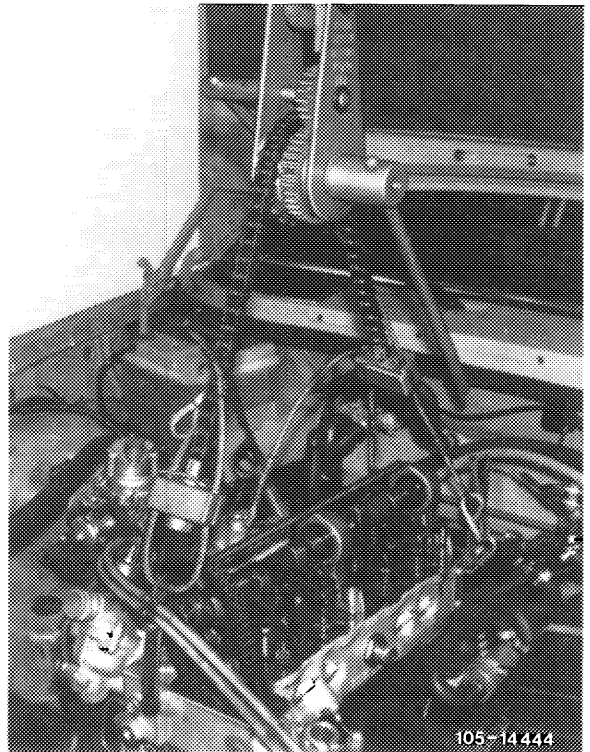

Installation

25 Mount new cylinder head gasket.

26 Mount cylinder head, while paying attention to hollow dowel pins for locating cylinder head.

27 Lubricate cylinder head bolts on threads and on head contact area and insert.

28 Tighten cylinder head bolts stepwise in sequence of tightening diagram starting with bolt 1.

1st step M 12 bolts 40 Nm
M 10 bolts 30 Nm

2nd step M 12 bolts 70 Nm
M 10 bolts 55 Nm

setting time 10 min

3rd step M 12 bolts 110 Nm
M 10 bolts 55 Nm

Tighten M 8 bolts with Allen wrench.

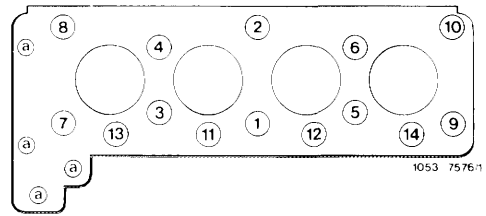

29 Place camshaft sprocket with timing chain on camshaft, paying attention to color code marks.

30 Position necked-down bolt for attaching camshaft sprocket and tighten to 80 Nm. For this purpose, counterhold camshaft sprocket by means of a screw driver or steel pin.

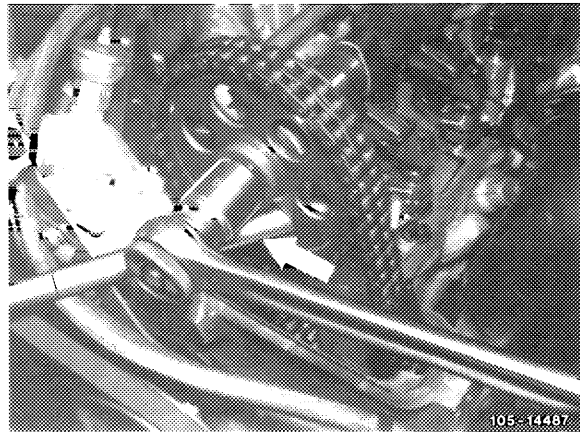

31 Rotate engine on crankshaft by means of tool combination and set to ignition TDC of 1st cylinder. Check tuning marks.

If cylinder head face has been machined, check timing (05-215).

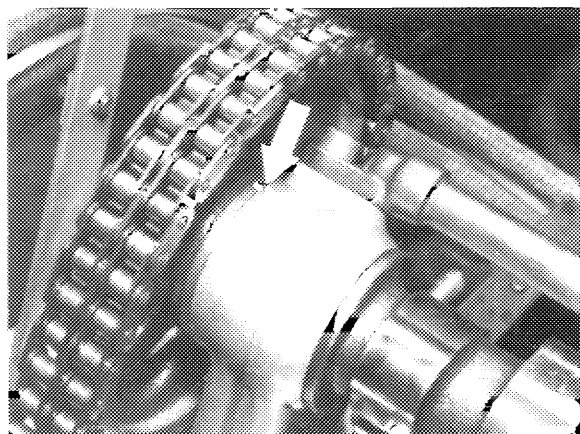
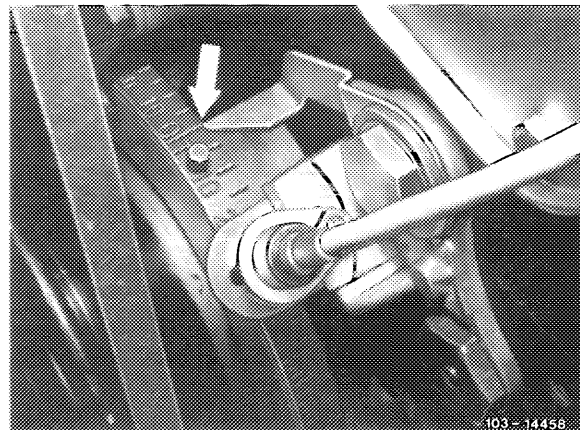

32 Adjust valve clearance (05–210).

For further installation proceed vice versa to removal.

33 Run engine and check for leaks.

34 Check for dwell angle and firing point (15–500).

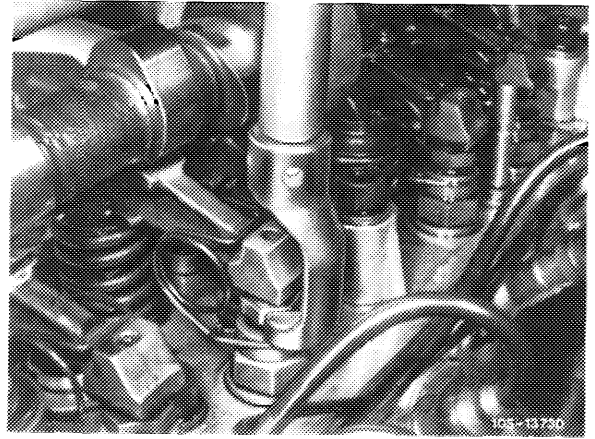

Cylinder head and cylinder head cover

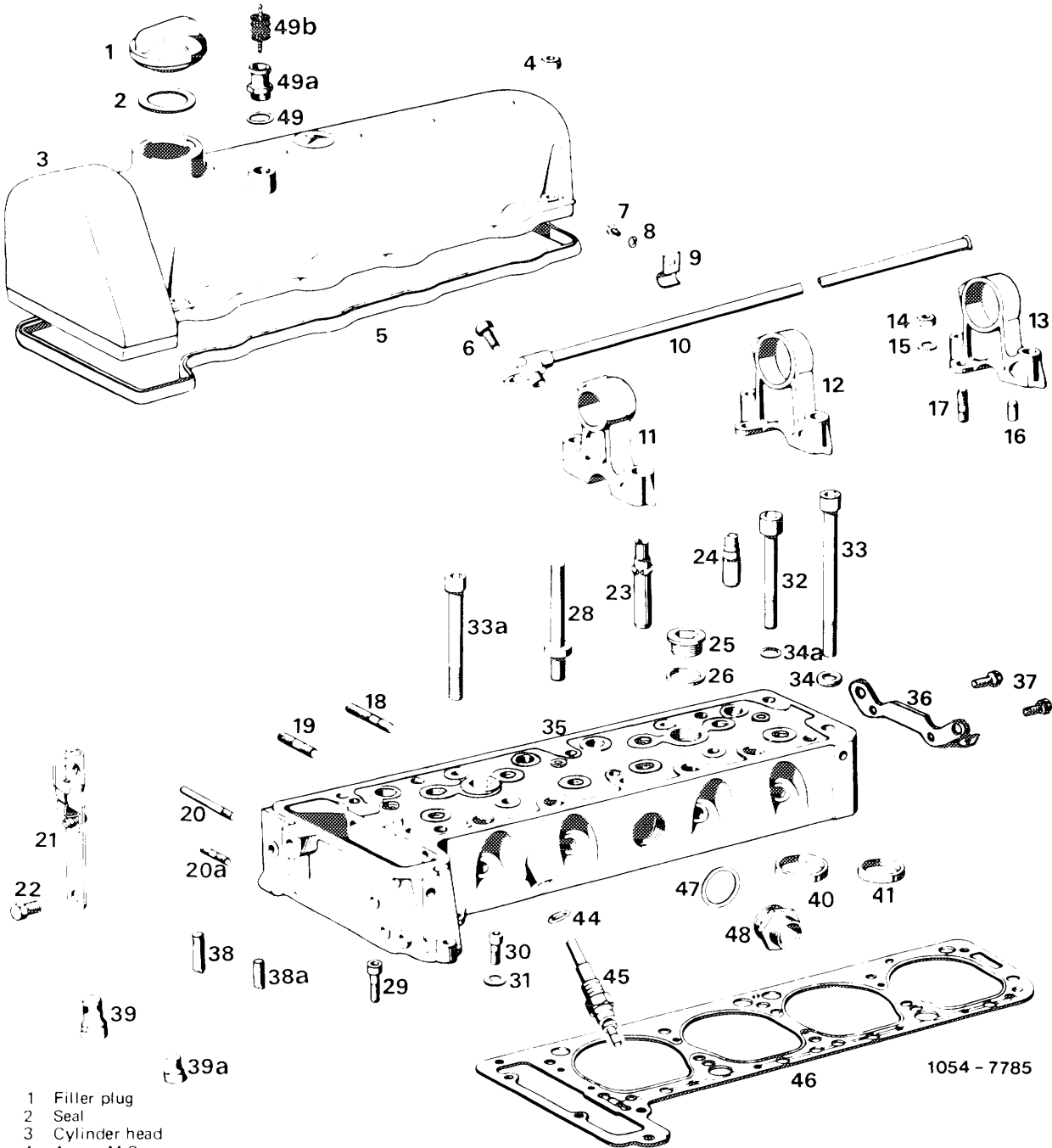

- 1 Filler plug
- 2 Seal
- 3 Cylinder head
- 4 nuts M 8
- 5 Cylinder head cover gasket
- 6 Screw M 6 x 15
- 7 2 screws M 4 x 10
- 8 2 springs washers B 4
- 9 2 pipe clips
- 10 Oil pipe
- 11 Camshaft bearing – crank end
- 12 Camshaft bearing
- 13 Camshaft bearing
- 14 3 nuts M 8
- 15 3 washers M 8
- 16 6 cylinder pins 8 x 8
- 17 3 studs M 8 x 18
- 18 5 studs M 10 x 52
- 19 Stud M 10 x 30
- 20 2 studs M 8 x 75
- 20a 2 studs M 8 x 20
- 21 Suspension eye
- 22 Screw
- 23 4 valve guides intake
- 24 4 valve guides exhaust
- 25 2 closing plugs M 22 x 1.5
- 26 2 sealing rings A 22 x 27
- 28 4 studs
- 29 Screw M 8 x 40
- 30 2 screws M 8 x 20

- 31 Washer 8.4
- 32 4 cylinder head bolts M 10 x 90
- 33 6 cylinder head screws M 12 x 145
- 33a 4 cylinder head screws M 12 x 105
- 34 10 washers
- 34a 4 washers
- 35 cylinder head
- 36 Suspension eye
- 37 Screw M 8 x 16
- 38 Water distributor
- 38a 4 water distributors
- 39 2 water distributors
- 39a 4 water distributors
- 40 Valve seat ring intake
- 41 Valve seat ring exhaust
- 44 Sealing ring A 14 x 18
- 45 Thermo-couple
- 46 Cylinder head gasket
- 47 Sealing ring A 32 x 38
- 48 Joint heating connection
- 49 Sealing ring A 18 x 22 (engines 115.923/926/951)
- 49a Connections (engines 115.923/926/951)
- 49b Flame arrester filament (AUS) starting October 1974 up to start of model year 1977, (J) starting January 1973, up to model year 1976, (USA) 1972–1974