

## 05—250 Removal and installation of valve springs

Valve clearance	with engine cold (approx. 20 °C)	with engine warm (60 °C ± 15 °C)
Intake	0.10 <sup>1)</sup>	0.15 <sup>1)</sup>
Exhaust	0.20	0.25

<sup>1)</sup> 0.05 mm higher during lasting outside temperatures below –20 °C.

Tightening torques	Nm
Nuts for cylinder head cover	15
Valve adjusting screws	20–40

### Special tools

Magnetic lifter for valve cone halves  11004-6202 116 589 06 63 00

Pressure lever for valve spring  11004-7664 123 589 03 61 00

Valve adjusting wrench 17 mm, 1/2" square  11004-6201 110 589 00 01 00

Socket 27 mm, 1/2" square, for rotating engine  11004-6193 001 589 65 09 00

Contact handle for rotating engine (component of compression pressure recorder (compressometer) 001 589 46 21 00)  11004-8487 001 589 46 21 08

### Conventional tool

Cylinder leak tester e.g. made by Bosch, EFAW 210 A and by SUN, CLT 228

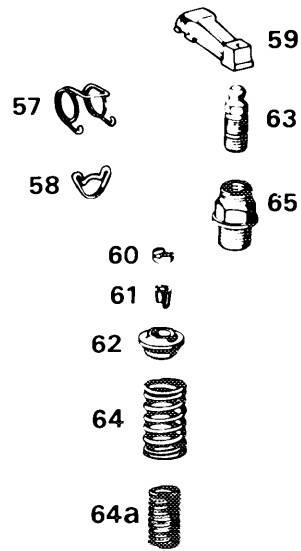

Valve timing

- 57 Tensioning spring
- 58 Annular spring
- 59 Rocker arm
- 60 Thrust piece
- 61 Valve cone halves
- 62 Valve spring retainer
- 63 Valve adjusting screw
- 64 Outer valve spring
- 64a Inner valve spring  
(not applicable when using  
outer valve spring  
110 053 01 20)
- 65 Threaded bushing
- 66 Valve stem seal intake
- 67 Valve stem seal exhaust
- 69 Rotocap
- 70 Intake valve
- 71 Exhaust valve

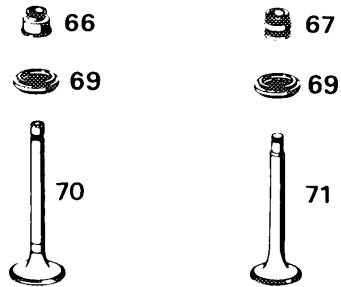

1054 - 7783

**Note**

For standardization reasons, the same **outer valve spring** is mounted as on 6 and 8-cylinder engines starting the middle of 1979. Since this spring has greater spring tension, the inner valve spring was dispensed with at the same time.

Outer valve spring 110 053 01 20  
Color coding yellow/red or violet/red

**Start of series**

Model	starting chassis end No.
123.000	136 067
123.020	110 670
123.023	136 067
123.043	012 303
123.083	002 715

In case of repair, this spring can also be mounted on vehicles with a lower chassis end number. In this event, remove inner valve spring (item 64a).

Both valve versions may be mounted on an engine at the same time.

On engines with high speed rates, we recommend simultaneously to replace the rotocaps.

### Removal

---

- 1 Remove rocker arm (05–230).
- 2 Unscrew spark plug of respective cylinder.
- 3 Remove thrust piece (60).

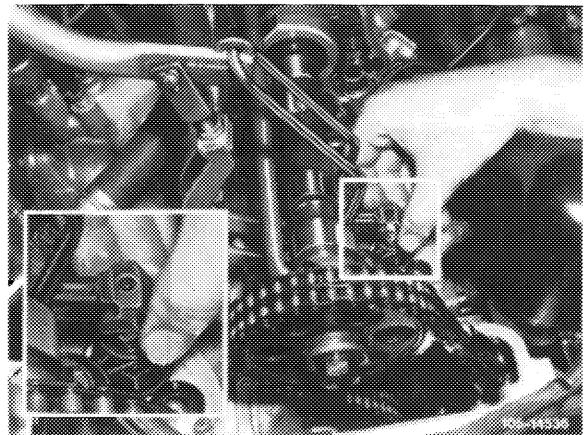

- 4 Set piston of respective cylinder to ignition TDC.

For this purpose, rotate crankshaft by means of tool combination.

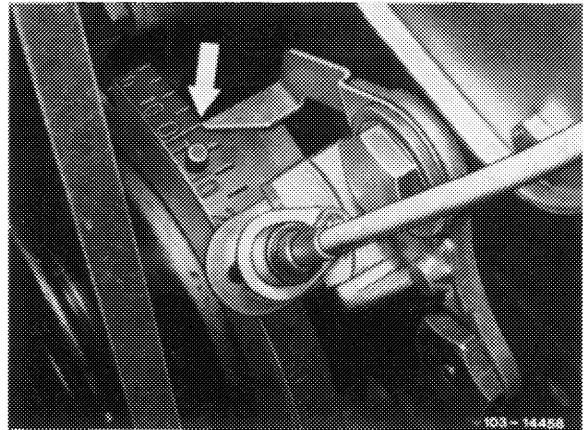

- 5 Screw compressed air hose of cylinder leak tester into spark plug bore and put cylinder under pressure.

- 6 Loosen valve cone halves by means of light hammer blows against valve spring retainer.

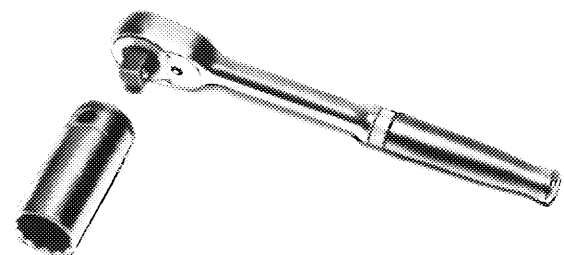

7 Push valve spring retainer (62) down by means of remover and installer and remove valve cone halves (61) with magnetic lifter.

Valves should not rest on piston ground during removal.

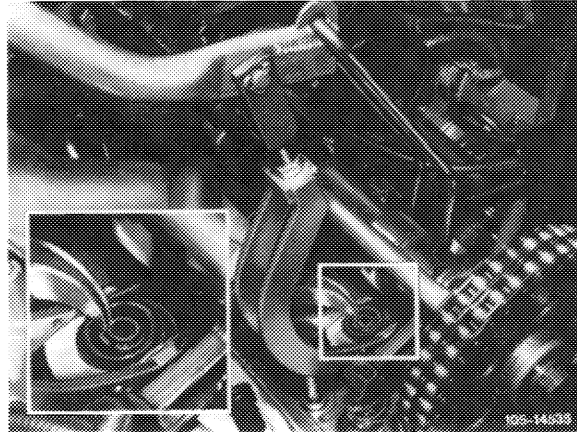

8 Remove valve spring retainer and valve springs.

9 Check valve springs and renew according to condition (05-260).

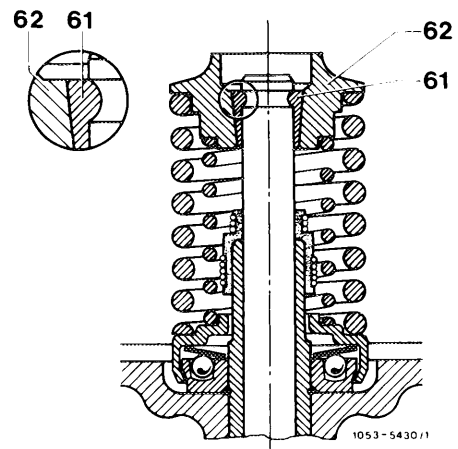

### Installation

---

10 Insert valve spring with close coils toward cylinder head.

11 For further installation proceed vice versa to removal.

12 Adjust valve clearance (05-210).

