

A. Stromberg carburetor 175 CDT in model 115

The Stromberg carburetor is a cross-draft carburetor.
The designation **175 CDT** means:

- 175 = 1 3/4" (45 mm) intake manifold dia.
- CD = constant depression (constant vacuum)
- T = temperature-controlled automatic choke

The carburetor comprises four main components:

- Carburetor cover
- Carburetor housing
- Float chamber
- Automatic choke

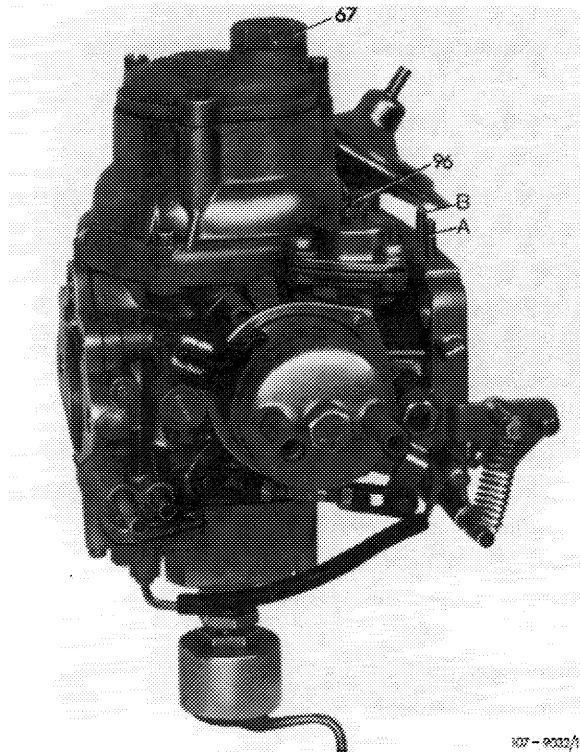

- A Vacuum connection for vacuum governor
- B Vacuum connection for ignition timing
- 67 Closing plug
- 96 Pulldown adjusting screw

107-9532/1

- 1 Carburetor housing
- 36 Temperature-controlled compensating element for fuel jet
- 38 Idle speed shutoff valve
- 39 Float needle valve
- 45 Float
- 46 Air piston
- 48 Air piston diaphragm
- 50 Float chamber
- 51 Jet needle
- 53 Compression spring
- 54 Carburetor cover
- 60 Dashpot piston
- 62 Capillary
- 67 Closing plug
- 81 Vent pipe
- 109 Vacuum diaphragm
- 110 Fuel return valve
- 111 Vacuum hose
- 112 Throttle valve

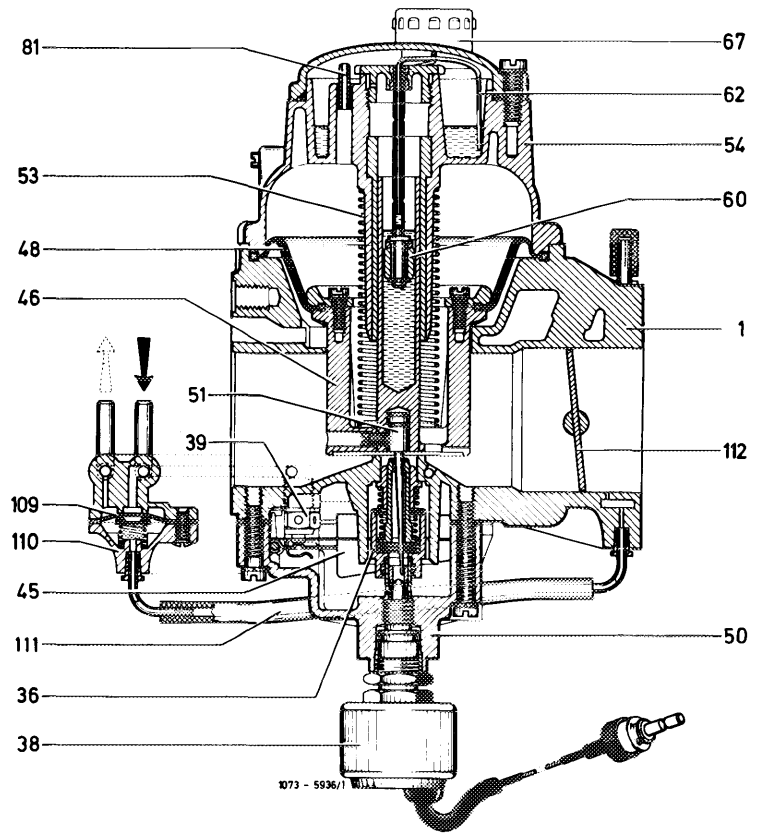

Layout and operation of Stromberg carburetor differ considerably with regard to other carburetor types. The Stromberg carburetor operates with a variable air horn cross section. For fuel metering it is provided with one conical jet needle sliding inside fuel jet to cover entire speed and load range.

The air horn is thereby adapted to air flow rate, which is determined by the throttle valve gap, the engine speed and the engine load. This will provide a constant air velocity and a constant vacuum at fuel jet. This constant vacuum in turn makes sure of good fuel atomization throughout entire speed and load range of engine, in particular at low engine speed and full load position of throttle valve.

The Stromberg carburetor has no separate idle speed and accelerating system.

Float

The float comprises the float chamber (05), the solid float (45) and the float needle valve (39). The float needle (137) is automatically opened by means of a wire clip (136) to protect needle against sticking. The float needle is additionally provided with a spring-loaded ball for reliable closing.

The fuel delivered by the fuel pump flows into float chamber and lifts float (45) in upward direction. When the fuel is at the specified level, the float needle (137) will lock the fuel feed.

As soon as the fuel level and thereby the float (45) drops, the float needle (137) will open the fuel feed under the influence of its own deadweight.

The wire clip (136) becomes effective only when the float needle is stuck and will open the float needle (137) automatically under influence of float weight.

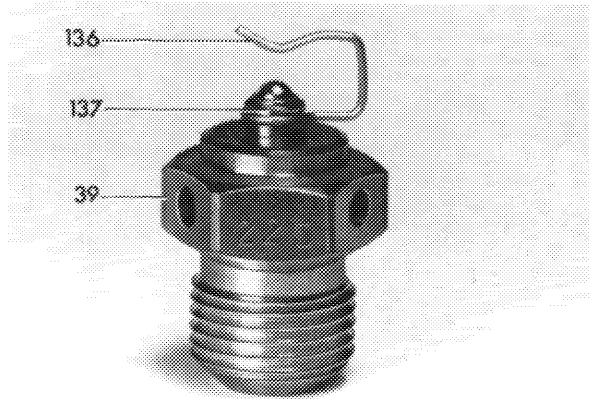

107-8354/j

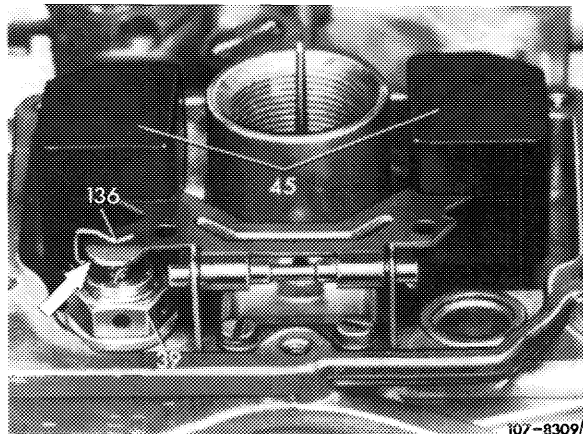

107-8309/j

Float chamber ventilation

The carburetor has inside ventilation only. Float chamber is ventilated by way of duct (arrow). This will prevent fuel vapors from escaping into the atmosphere (protection of environment).

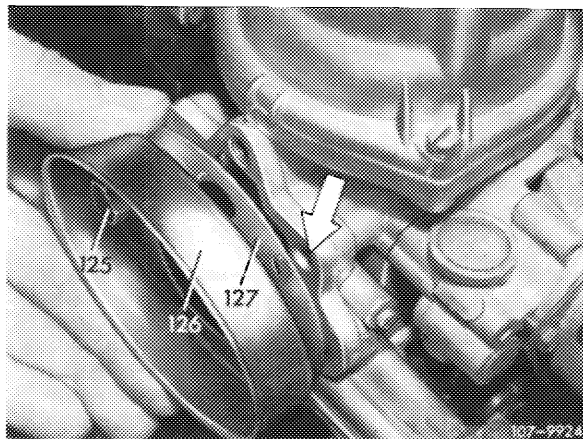

107-9924

Idle speed — partial load — full load

The fuel flows from float chamber (50) into fuel jet (138), where its level is the same as that of the float chamber when the engine is not running.

At idle speed, the throttle valve (112) is opened by the idle speed adjusting screw for a small gap to provide the minimum intake cross section under air piston (46).

This will result in a vacuum, which becomes effective also in vacuum chamber (133) above air piston diaphragm (48) as a result of two bores (80) in bottom of air piston. The resulting difference in pressure between the vacuum chamber (133) and the pressure chamber (134) underneath air piston diaphragm will force the air piston (46) to rise.

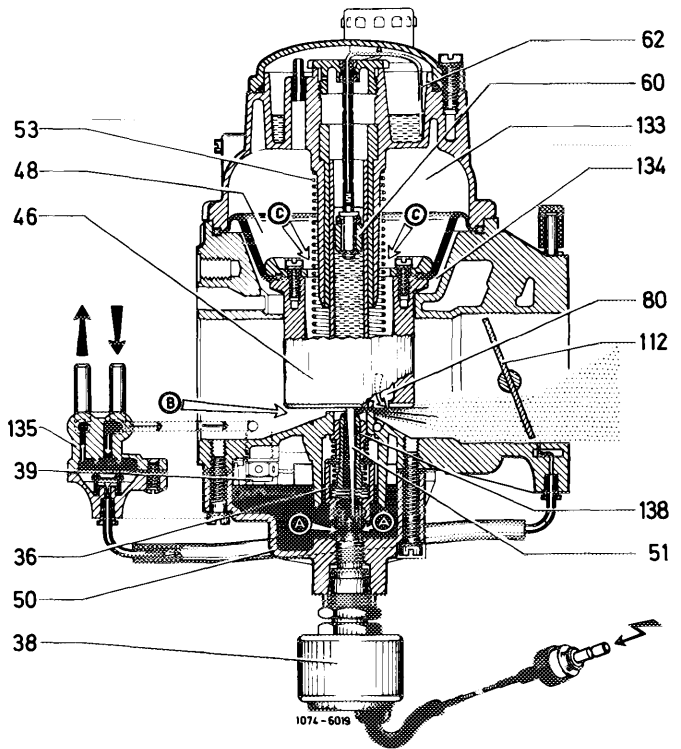

Operation at idle

- A Fuel inflow
- B Air inflow
- C Vacuum

Lifting of air piston (46) will increase the intake cross section and decrease the vacuum until a balance is established between the vacuum on the one end and the air piston weight and the force of the compression spring (53) on the other.

The air piston (46) will then move into a position which is in a given ratio with regard to throttle valve gap and air flow rate. Consequently, the vacuum at fuel outlet of jet (138) will remain almost constant.

The conical jet needle (51) is attached to air piston (46) and, depending on position of air piston, will establish a given annular gap in fuel jet (138).

The more air is drawn through carburetor, that is, the higher the air flow rate, the more will the air piston (46) be raised and the more fuel will accordingly be drawn out of fuel jet (138).

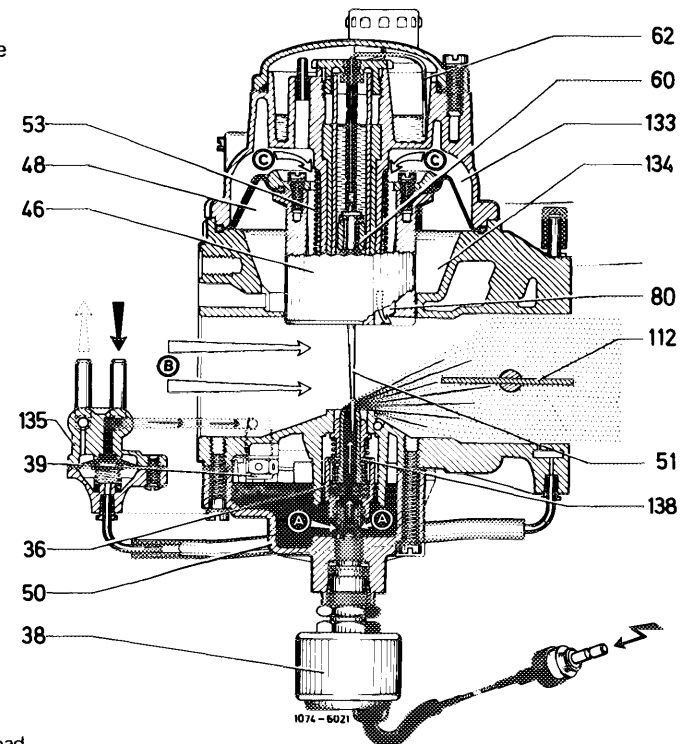

Operation at full load

Acceleration

A dashpot (60) located inside air piston (46) prevents an immediate upward movement of air piston when the throttle valve is suddenly opened. This will increase the vacuum at the fuel jet (138) for a short moment, so that more fuel will be drawn off to enrich the mixture.

The oil flows to the dashpot by way of a capillary (62). To guarantee perfect function of dashpot, use only specified oil grades.

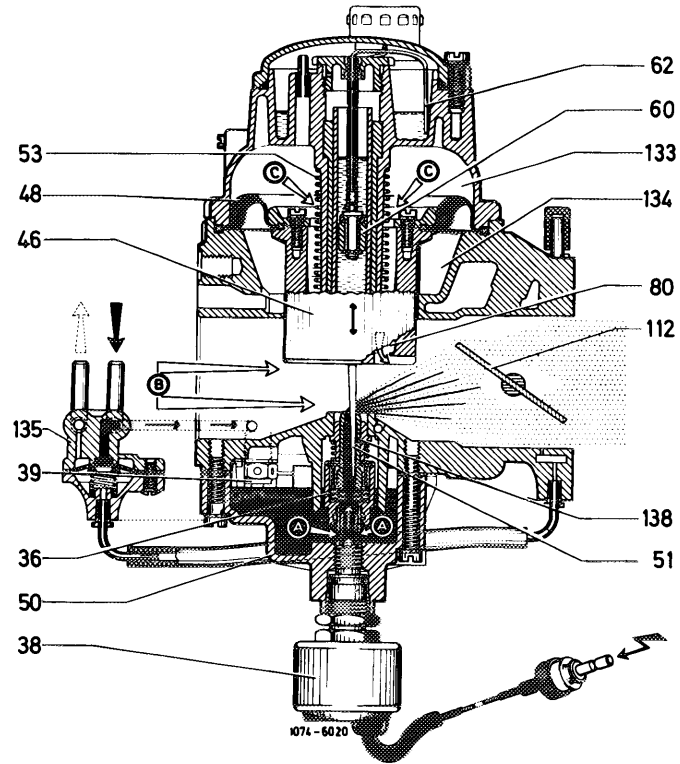

Operation during acceleration and at partial load

Temperature-controlled fuel jet and heating of jet assembly

The fuel jet (138) and a temperature-controlled compensating element (36) are combined into one unit. Bimetallic cup springs (140) will slightly adjust the fuel jet (138) in accordance with fuel temperature. As a result, the idle speed fuel volume will be optimally matched to the prevailing operating conditions of engine.

To prevent icing-up of fuel jet (138) at temperatures around freezing point in combination with high humidity, the jet assembly is heated via connection (6) when the righthand vehicle heater is switched on.

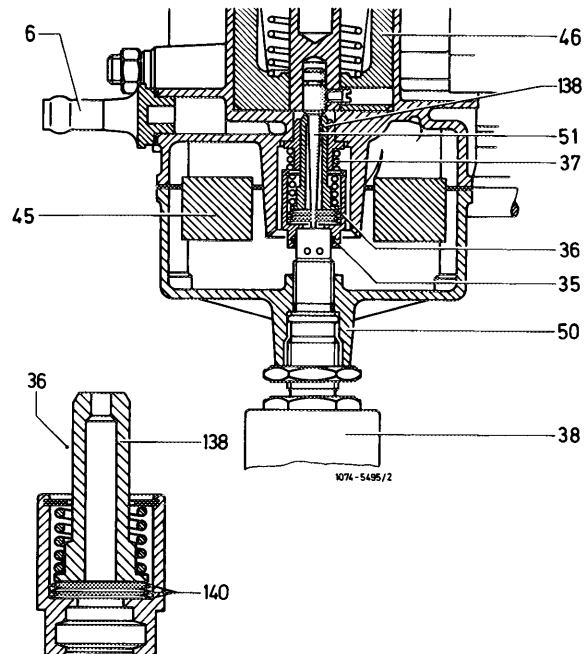

Idle speed shutoff valve

The electromagnetic idle speed shutoff valve (38) is screwed into float chamber (50) and serves the purpose of preventing any afterrunning of engine when the ignition is switched off.

The idle speed shutoff valve serves simultaneously as a regulating screw for the idle speed fuel volume.

When the ignition is switched off, the idle speed shutoff valve is energized by the delay switch (141) for **6–16 seconds** and will **lock** the fuel feed to the fuel jet during this period.

When the ignition is switched on, the idle speed shutoff valve is deenergized and therefore **open**.

This safety circuit guarantees that the fuel feed for jet is intact even if the electric circuit is interrupted.

A separate grounding cable (arrow) from intake manifold to carburetor housing establishes the ground connection to idle speed shutoff valve.

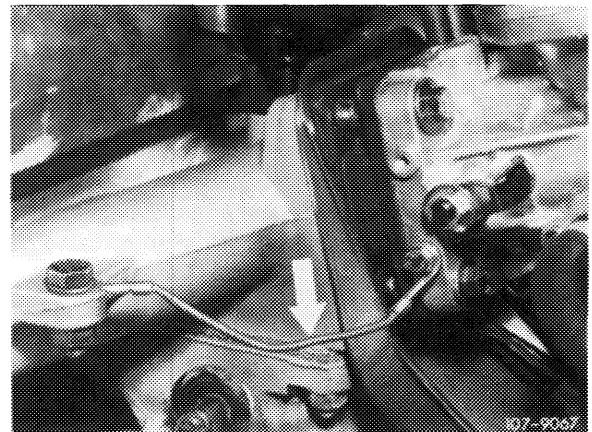
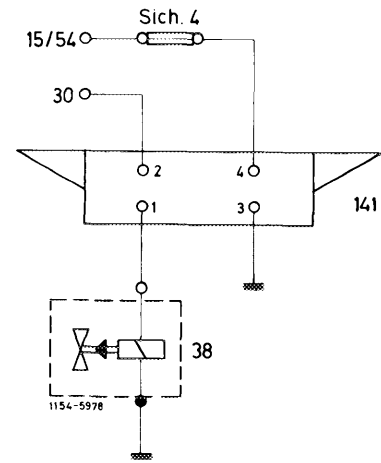

Choke system

The Stromberg carburetor 175 CDT is provided with an automatic choke which supplies the required starting and warming-up mixture in dependence of the ambient temperature and the coolant temperature, in combination with an electrically heated bimetallic spring (130).

The bimetallic spring (130) is located in choke cover (18) and is heated electrically and under influence of coolant.

Heating is required to prevent reengagement of choke when the engine is shut off for a short period.

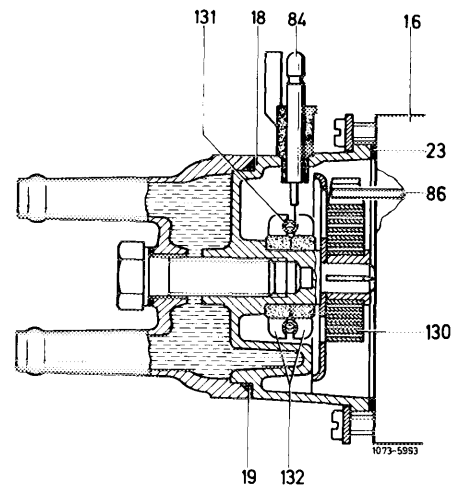

Cold start

Stepping down on accelerator pedal once will automatically add the choke system (starting device), that is, the bimetallic spring (130) returns to its starting position in accordance with outside temperature. The drive lever (86) is simultaneously pulled back by the bimetallic spring and the slide valve (91) is pushed down by a rod.

Choke rod and fast idle cam in "cold start position"

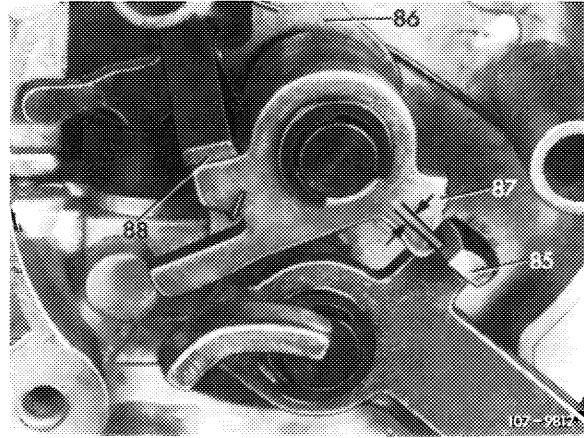

The slide valve (91) is pushed down in accordance with distance covered by bimetallic spring (130) to clear the calibrated bores for enrichment of fuel mixture. Rotation of fast idle cam (87), which is positively connected to drive lever (86), will open the throttle valve to a given gap by way of the cam segment, the choke rod (85) and a connecting rod, as a result of which the engine will run at increased speed upon firing.

Simultaneously, the pulldown diaphragm (98) is pushed down by spring (97) and opens the "start enrichment valve" (99). The fuel metered via fuel ducts (100) joins the fuel metered via choke valve bores prior to entering the mixing chamber (101).

The intake manifold vacuum generated upon starting, pulls the pulldown diaphragm (98) up to stop of adjusting screw (96) opposite to force of spring (97).

During this process, the diaphragm rod will pull the lever also for a given distance in upward direction by way of the choke valve. The choke valve (91) is pushed up accordingly by the compression spring of valve plate (92). As a result, the first bore is closed by the control edge in choke housing and the fuel-air mixture is made leaner.

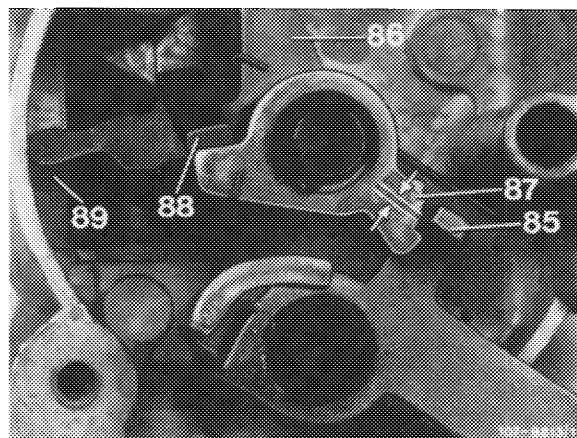
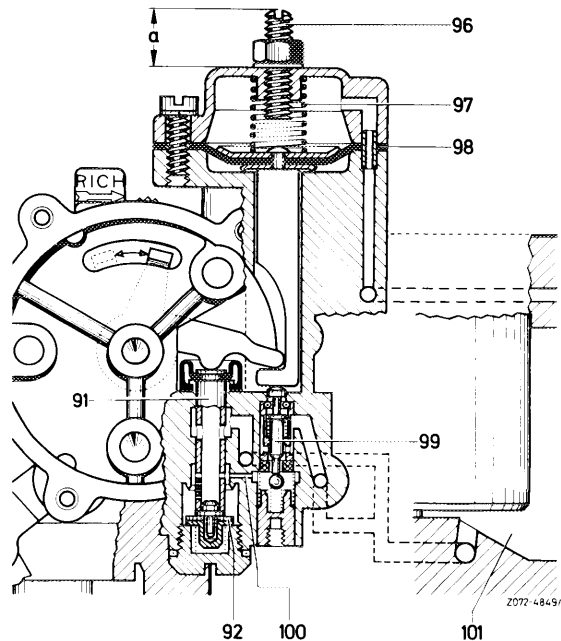

Choke rod and fast idle cam in "warm-up position"

The diaphragm rod pulled in upward direction closes the start enrichment valve. The fast idle cam (87) and the choke rod (85) are now in warm-up position, that is, the warm-up stage begins.

Positive disconnection of automatic choke during acceleration

At full throttle position of accelerator pedal in combination with a low engine speed, e.g. vehicles with automatic transmission on a steep garage exit, the vacuum above pulldown diaphragm (98) may drop to the extent that the restoring forces of the diaphragm and the bimetallic spring will push the diaphragm rod completely down. Both the choke sliding valve (91) and the start enrichment valve (99) will then again be fully added.

To prevent overenrichment, the lug on the fast idle cam (87) and the driver (88) are pushed in upward direction by way of the choke rod (85).

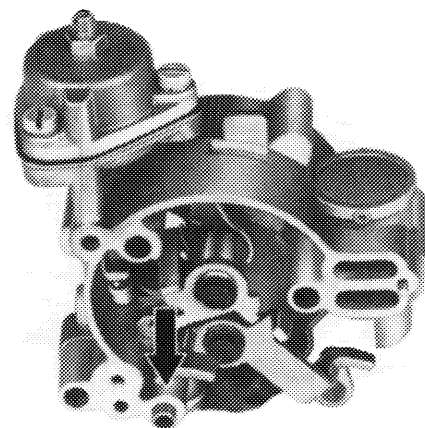

107-9018/1

The choke sliding valve (91) is also pushed in upward direction under influence of compression spring of valve plate (92), so that only the lowest slide valve bore and the start enrichment valve (99) are becoming effective.

With increasing temperature in choke cover the bimetallic spring provides continuously less resistance and the drive lever returns to its zero position. During this process, the compression spring of valve plate (92) pushes the choke slide valve (91) in upward direction until the bores are covered and valve plate (92) is completely shutting down the fuel feed.

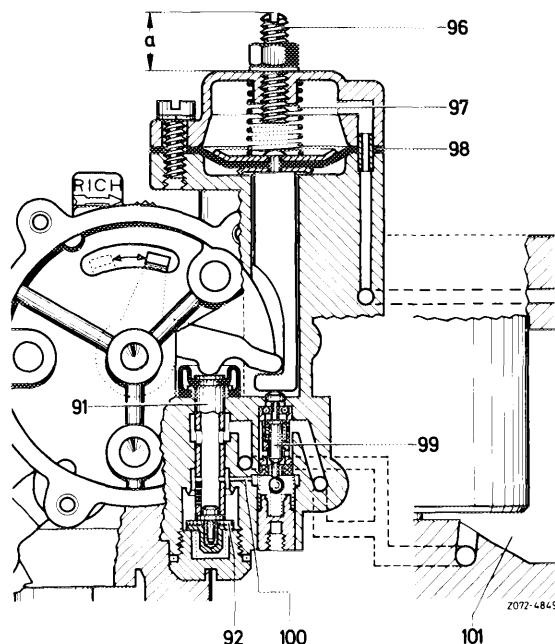

2072-4849/3

Driver (88) of drive lever (86) moves the fast idle cam (87) into the respective position in relation to choke rod (85), which will lift the throttle valve by way of the connecting rod until, with the engine at operating temperature, the throttle valve lever rests again against idle speed adjusting screw.

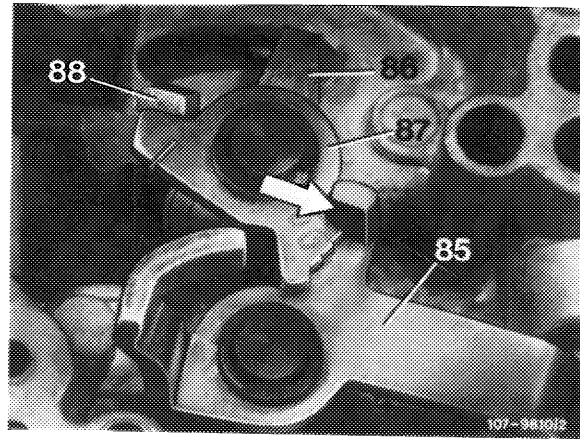

Fuel return valve

The fuel return valve is controlled by way of the intake manifold vacuum and serves the purpose of preventing the formation of vapor bubbles in fuel system.

When the vacuum is too high, e.g. during idle, the vacuum diaphragm (109) is attracted against the pressure of the spring and the return duct (106) to fuel return line is opened. When the vacuum drops, the diaphragm will close the return duct (106).

Opened

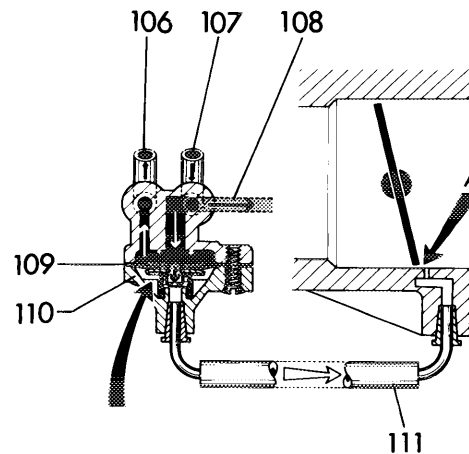

The vacuum bore is located in such a manner that the intake manifold vacuum is no longer effective beyond a given throttle valve gap. As a result, an adequate fuel supply at full load is ensured.

Closed

- 106 Return duct
- 107 Feed from fuel pump
- 108 Feed toward float chamber
- 109 Vacuum diaphragm
- 110 Cover
- 111 Vacuum hose

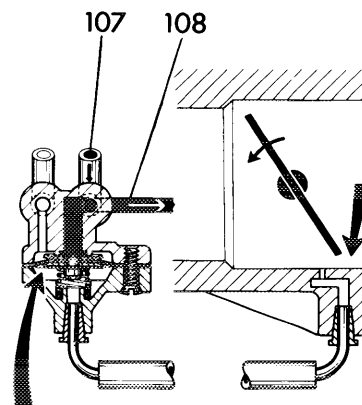

1074-5980

Vacuum governor (rpm stabilizer)

The vacuum governor is installed on vehicles with automatic transmission and/or air conditioning system and serves the purpose of stabilizing the idle speed with driving position engaged or air conditioning system added.

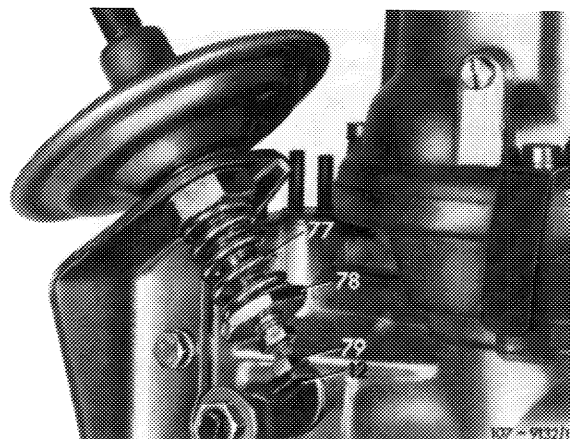

The vacuum tapping bore for the vacuum governor is located behind the throttle valve, so that the diaphragm of the governor is attracted by the high intake manifold vacuum at idle speed of engine.

When the driving position is engaged or the air conditioning system is added, the engine is put under load. The engine speed will drop and thereby also the intake manifold vacuum.

The compression spring (77) acts against the vacuum of the intake manifold. As soon as the spring force dominates, the throttle valve is slightly opened via adjusting screw (79) and throttle valve lever (12), so that the idle speed will be stabilized.

B. Stromberg carburetor 175 CDTU in model 123

The Stromberg carburetor 175 CDTU differs from carburetor 175 CDT as follows:

- New idle speed system.
- Idle speed shutoff valve located on intake manifold.
- New jet needle designated "MB".
- Choke housing with auxiliary air adjusting screw.
- New diaphragm cover for choke.
- Air piston lift via drag lever.
- Additional vacuum tapping pipe.
- Throttle for vacuum governor.
- No heater for jet assembly.
- Pulldown delay for choke (subsequently introduced into series, starting August 1977).

Vacuum connections

- 124 Auxiliary air adjusting screw
- A Intake preheater
- B Ignition timing
- C Vacuum governor

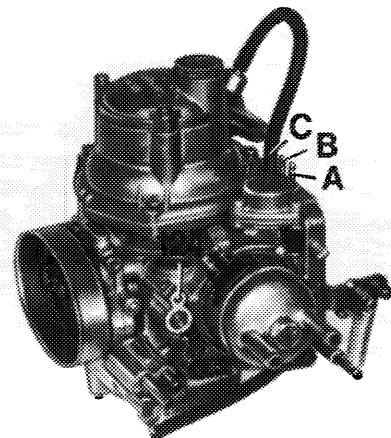

New idle speed system — operation

The vacuum generated by the engine is effective in mixing chamber (143) and at outlet of fuel jet (138).

As a result, the fuel is drawn out of fuel jet and mixes with the incoming intake air into the idle air mixture.

This idle air mixture flows via bypass mixture duct (146) and a fuel hose into intake pipe (144), while bypassing throttle valve (145). Only a low volume of idle speed mixture will enter the intake pipe through small throttle valve gap.

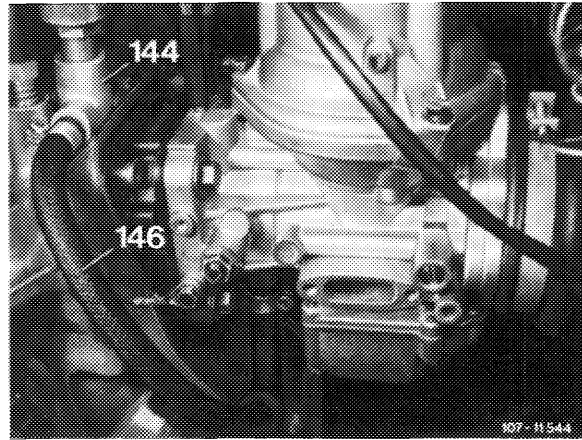

- 1 Air intake
- 2 Ambient air
- 3 Bypass mixture
- 8 Throttle valve adjusting screw
- 38 Idle speed shutoff valve
- 46 Air piston
- 138 Fuel jet
- 143 Mixing chamber
- 144 Intake manifold
- 145 Throttle valve
- 146 Bypass mixture duct
- 147 Bypass mixture adjusting screw
- 148 Ambient air duct
- 149 Ambient air adjusting screw
- 150 Safety cap
- 151 Safety cap
- 152 Fuel adjusting screw

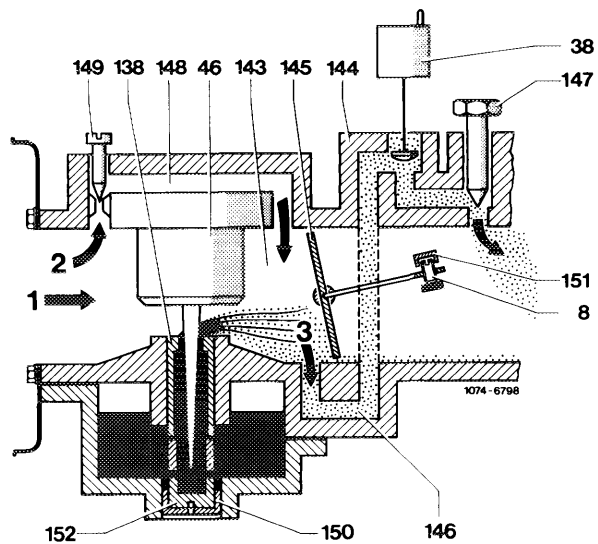

The bypass mixture volume and thereby the idle speed are regulated by means of the bypass mixture adjusting screw (147) in a limited speed range.

Note: If the adjusting range of the bypass mixture adjusting screw is not enough to regulate to specified idle speed, a correction of basic position for throttle valve is required. (07.2—105).

To prevent afterrunning of engine, the idle speed shutoff valve (38) closes the bypass mixture duct when the ignition is switched off.

The idle speed shutoff valve is connected in parallel with choke cover heater.

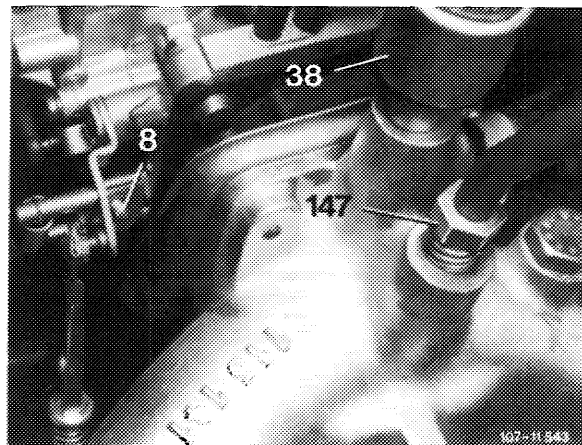

Prior to delivery of vehicle, the ambient air duct (148) is made inoperative by completely closing the ambient air adjusting screw (149). The ambient air adjusting screw is no longer used for setting the idle speed emission value as originally intended. The idle speed emission value is set by means of fuel adjusting screw (152) (07.2–100 and 07.2–110).

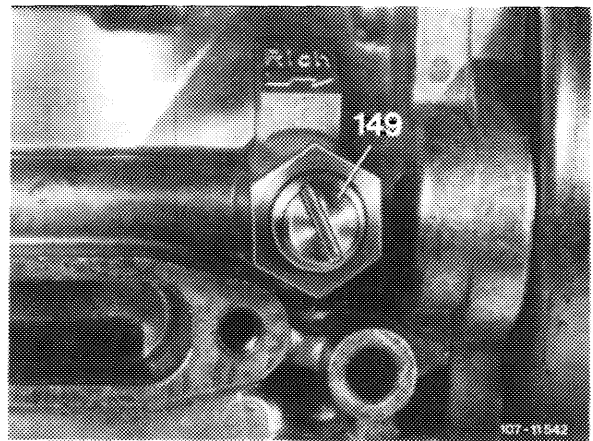

Choke housing with auxiliary air adjusting screw

For better adaptation of warming-up mixture, the choke housing is provided with an auxiliary air adjusting screw (124) on engine.

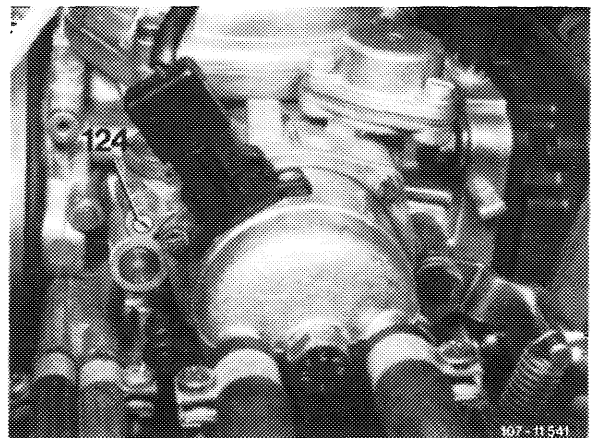

The auxiliary air (1) is taken from clean air side and routed to choke slide valve, where it is mixed with the fuel to provide the warming-up mixture.

The adjusting screw (97) for diaphragm lift is designed as a set screw and permanently adjusted by manufacturer.

Attention!

Do not readjust this adjusting screw. The cold start emission value is regulated by means of the auxiliary air adjusting screw.

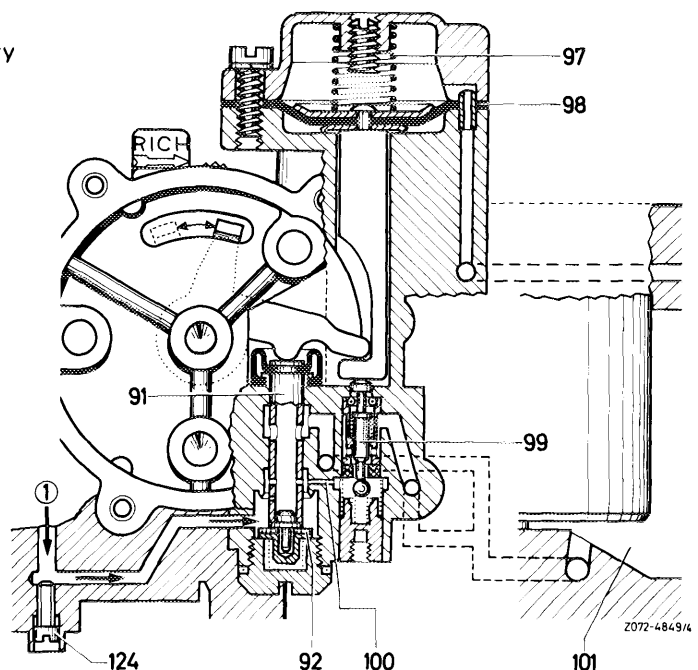

Air piston lift via drag lever

The tickler (2) for lifting the air piston is lifted via drag lever (arrow). This will protect tickler against binding in guide bushing.

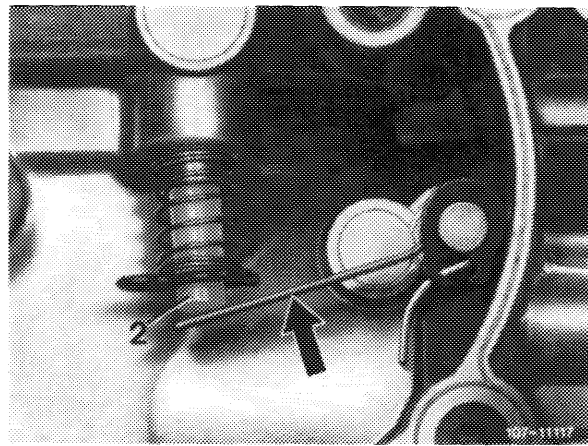

Additional vacuum tapping pipe

A vacuum tapping pipe A is installed for load-dependent control of intake air preheating.

Throttle for vacuum governor

A throttle is pressed into vacuum tapping pipe C for vacuum governor (arrow). As a result, the throttle valve will close at a slight retard during deceleration.

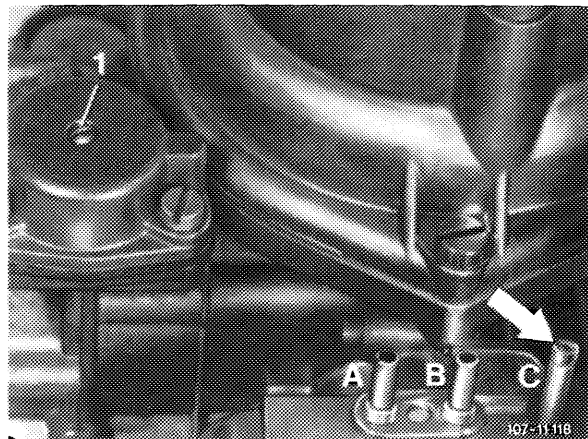

- A Intake air preheater (blue colored ring)
- B Ignition timing (red colored ring)
- C Vacuum governor (without colored ring)

Pulldown delay for choke

Starting August 1977 a pulldown delay is installed within scope of technological advance.

This will improve smooth running of engine directly following a cold start.

Layout and operation

The pulldown delay comprises the following components:

- Thermo time switch (165)
- Electric switchover valve (164)
- Vacuum lines (2, 3, 5)
- Electric harness

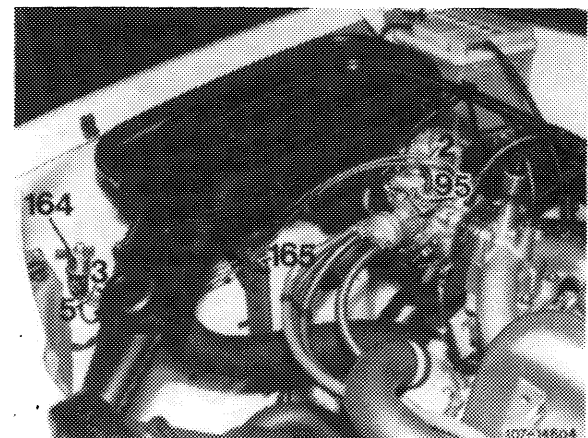

Pulldown delay depends on temperature in engine compartment. The delay period is controlled by a thermo time switch (165), which delays the vacuum supply from intake manifold to choke housing (95) via switchover valve (164) up to approx. + 35 °C.

- 14 Heater resistance
- 15 Bimetallic spring
- 16 Ground connecting contact
- 91 Choke sliding valve
- 95 Choke housing
- 98 Pulldown diaphragm
- 99 Start enrichment valve
- 164 Switchover valve
- 165 Thermo time switch
- a+ For fuse No. 14 for pulldown delay, choke cover heater, signal horn and idle speed shutoff valve

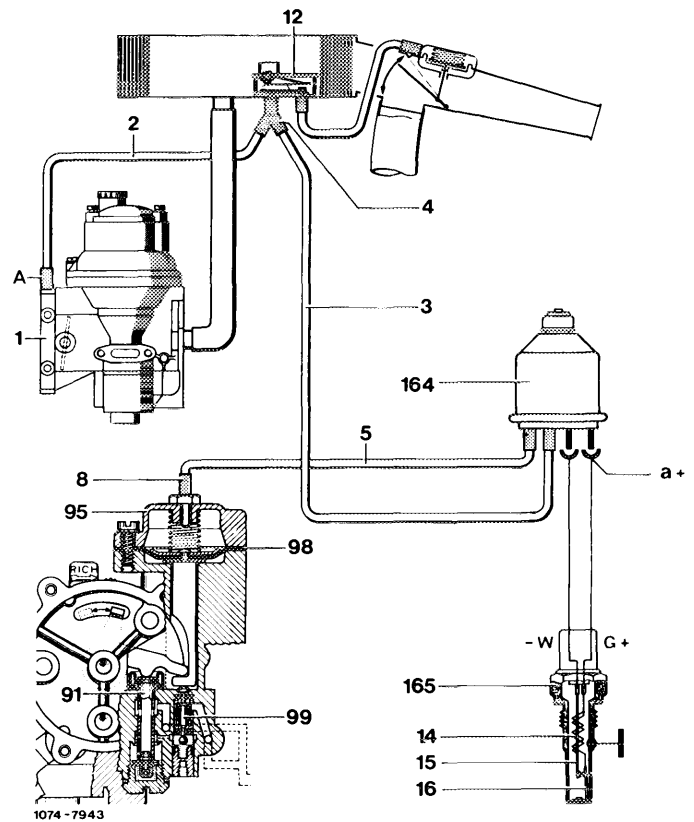

After switching on ignition, the switchover valve is energized via choke cover heater. Thermo time switch (165) terminal "G" is simultaneously energized.

Since the ground connecting contact (16) in thermo time switch is closed, the current flows via heater resistance (14) to ground connection. The switchover valve is thereby connected in such a manner that the intake manifold vacuum toward pulldown diaphragm (98) is interrupted.

As a result, the pulldown diaphragm cannot be attracted for the moment with the engine running, and the start enrichment valve (99) remains open.

With increased heating of bimetallic spring (15) in thermo time switch through heating resistance (14) in accordance with a specified delay period (depending on respective ambient temperature), the ground connecting contact (16) in thermo time switch will switch. The interruption of the ground connection will activate the switchover valve and the intake manifold vacuum will be free to pass. The pulldown diaphragm (98) is attracted, the start enrichment valve (99) is closed and the choke slide valve (91) will be switched from starting to warm-up position.

Note: The delay period depends on the ambient temperature and amounts to max. 27 seconds at $-20\text{ }^{\circ}\text{C}$.

Delay periods

Thermo time switch temperature	Delay period
+35 $^{\circ}\text{C}$	0 seconds
+20 $^{\circ}\text{C}$	2–10 seconds
0 $^{\circ}\text{C}$	10–18 seconds
– 5 $^{\circ}\text{C}$	12–20 seconds
–10 $^{\circ}\text{C}$	14–22 seconds
–15 $^{\circ}\text{C}$	15–24 seconds
–20 $^{\circ}\text{C}$	17–27 seconds