





## 07.2–125 Checking, adjusting choke

### Testing and adjusting values

	Standard version	 1977–1978	 1979–1981	 1974–1978  1977–1979	 1980–1981
Choke cover code number	200 <sup>2)</sup>	102	200	102	200
Choke cover preload	on mark				
Warm-up speed <sup>1)</sup>	1800–2000		1800		
Warm-up CO value <sup>1)</sup>		5–6 <sup>3)</sup>		–	5–6

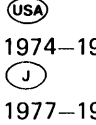
<sup>1)</sup> Testing and adjusting at 75–85 °C engine oil temperature on 2nd detent (pulldown detent).  
On national version **without air injection** and **without EGR**.

<sup>2)</sup> This choke cover replaces all previous versions.

<sup>3)</sup> Model 115 standard version 6–7 % CO.

### Special tools

Oil telethermometer



116 589 27 21 00

Clamp

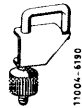

000 589 40 37 00

Tester for vacuum 0–1000 mbar

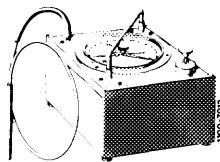

116 589 25 21 00

## Conventional tools

Revolution counter, CO measuring instrument, voltmeter, vacuum tester

Digital tester

e.g. made by Bosch, MOT 001.03

## Testing, adjusting

1 Connect testers:

- Digital tester or revolution counter
- Oil telethermometer
- Voltmeter
- Vacuum tester

2 Test battery starting voltage.

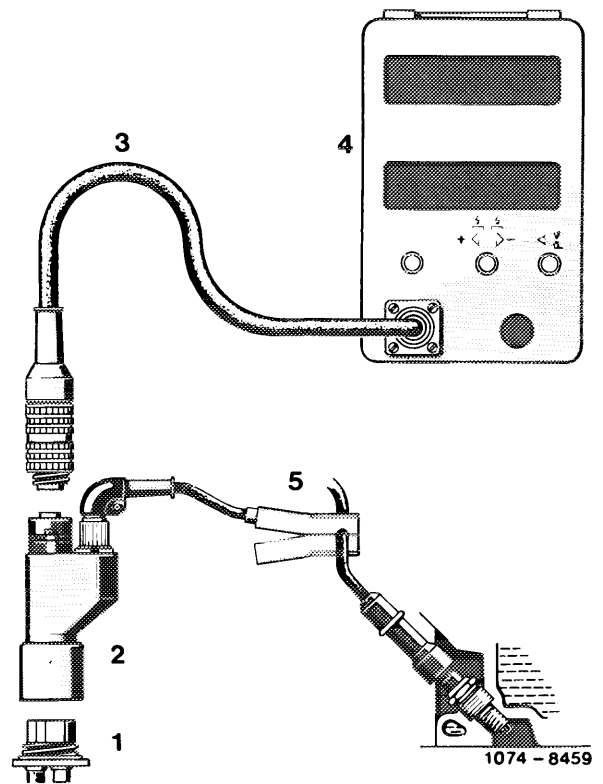

3 Test choke cover mark.

On choke cover version 1 the mark of choke cover (arrow) should be opposite lefthand mark on choke housing, if required, loosen choke cover and set accordingly.

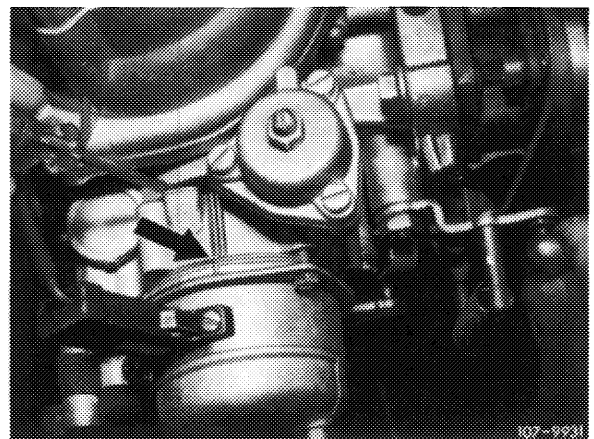

On choke housing version 2 the markings (arrow) should be in alignment opposite each other.

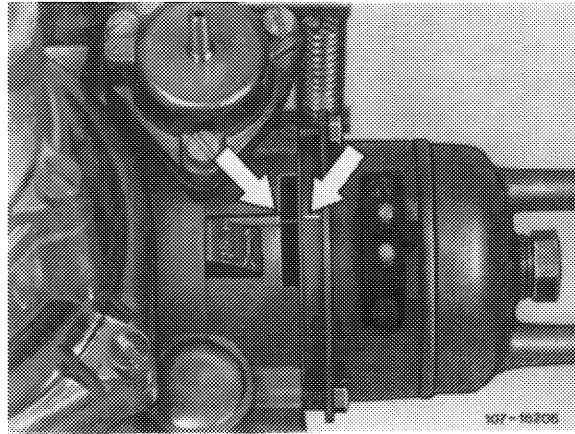

#### 4 Check diaphragm of choke for leaks.

This step applies only to vehicles on which the carburetor has a vacuum connection on pulldown cover of automatic choke.

Instead of the vacuum tester listed as a special tool, a conventional vacuum tester with respective measuring range may also be used.

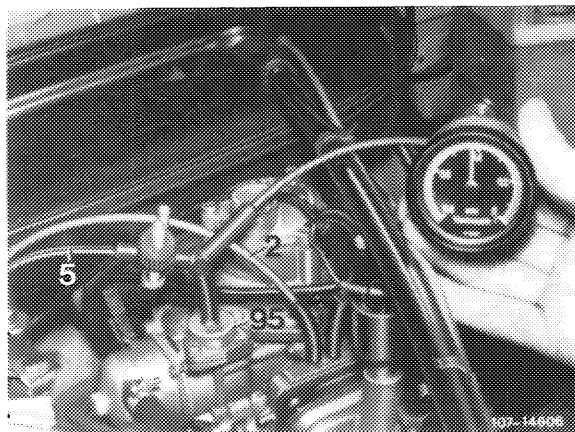

### Testing

---

- 1 Plug Y-rubber member to vacuum connection of pulldown cover (95) and connect vacuum tester.
- 2 Run engine and watch establishment of vacuum on tester. If vacuum is not increasing still further, pinch Y-rubber member with hose clamp.
- 3 Stop engine and watch needle of vacuum tester for approx. 1–2 minutes. If vacuum drops, a leak is indicated (e.g. vacuum connection in pulldown cover, gasket for pulldown cover, pulldown diaphragm). Replace faulty parts (07.2–136).
- 5 Run engine oil temperature to 75–85 °C.
- 6 Check pulldown delay.

Wiring diagram pulldown delay

- 21 Choke cover heater
- 164 Switchover valve
- 165 Thermo time switch
  - a Fuse No. 14 for pulldown delay, choke cover heater, signal horn and idle speed shutoff valve

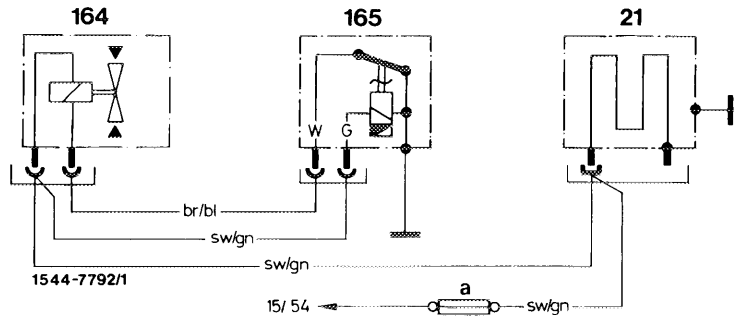

Testing

<p>Connect vacuum tester. Remove thermo time switch (165), cool down below +35 °C (e.g. with tap water). Connect thermo time switch to ground only to the extent that it will not heat up. Start engine, vacuum should not be indicated immediately, but under delay.</p>	
<p>Vacuum readout delayed.</p>	<p>Vacuum readout immediately or none.</p>

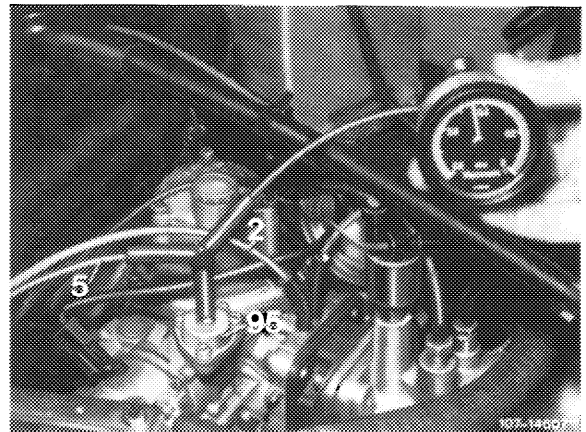

Testing thermo time switch (165) and switchover valve (164)

a) If vacuum is indicated "immediately", check layout of vacuum line. Pull electric coupling from switchover valve (164). One bushing should be connected to voltage, the other to ground.

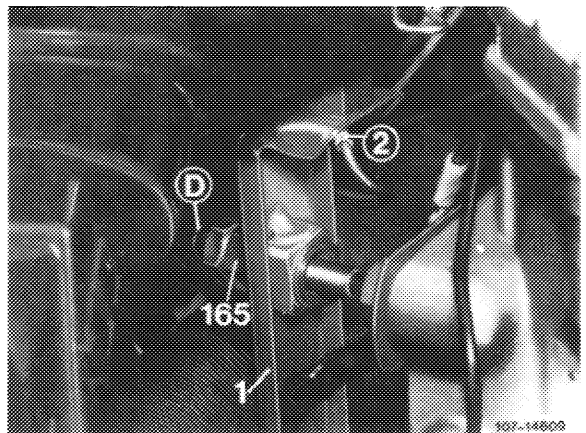

If no voltage shows up, check fuse and line layout by means of wiring diagram.

If there is no ground connection, replace thermo time switch.

If there is voltage and ground connection, replace switchover valve (164).

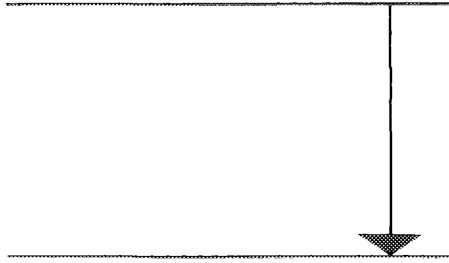

b) If "no" vacuum is shown on pressure gage, check whether line (3) is connected to vacuum. If not, replace temperature regulator (12) in air cleaner housing.

If line (3) is connected to vacuum, check activation of switchover valve (164). Pull electric coupling from switchover valve, one bushing (jack) should be connected to voltage, the other to ground.

If no voltage is indicated, check fuse and line layout by means of wiring diagram.

If there is no connection to ground, replace thermo time switch (165).

If connection to voltage and ground is indicated, replace switchover valve (164).

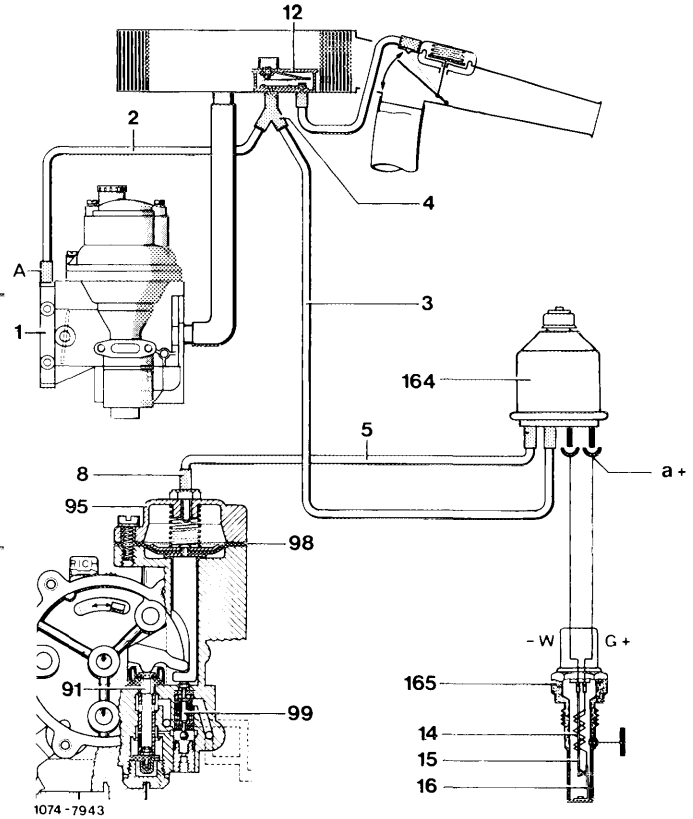

End of test

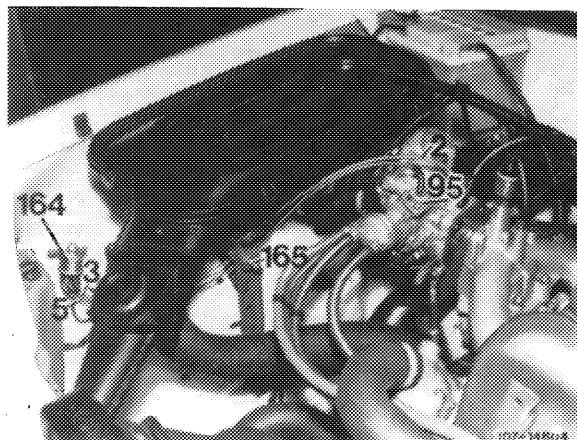
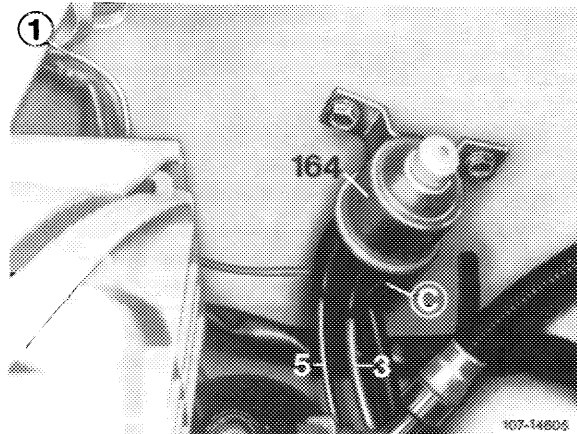

7 Check warm-up speed and warm-up CO value and adjust, if required.

On national versions (AUS) (J) (S) (USA) the air injection as well as EGR should be made inoperative prior to test as follows:

Make EGR inoperative by pulling vacuum hose from EGR valve (31).

Make air injection inoperative (07.2–110).

Model 115

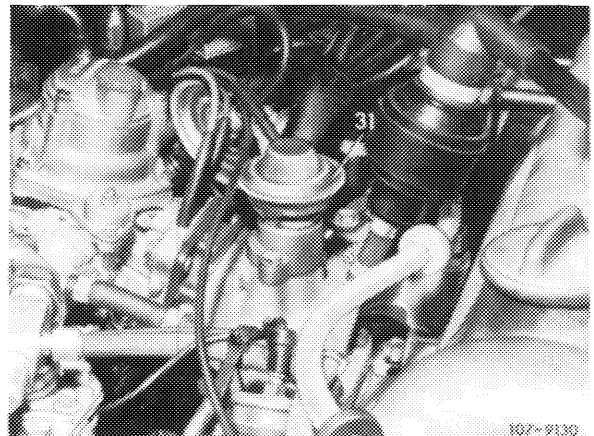

Model 123

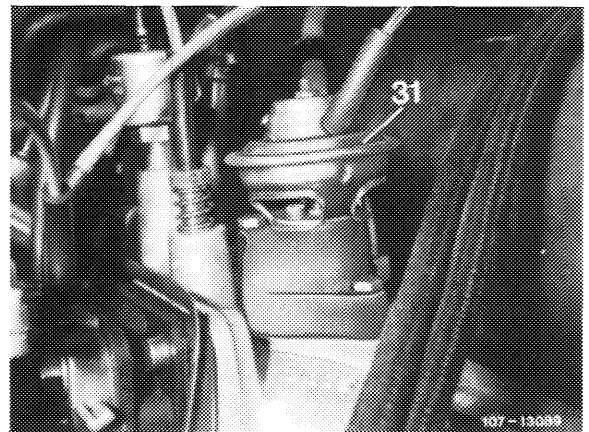

**Check warm-up speed and adjust, if required.**

For this purpose, with engine running, lift throttle valve lever until 2000–2200/min are attained.

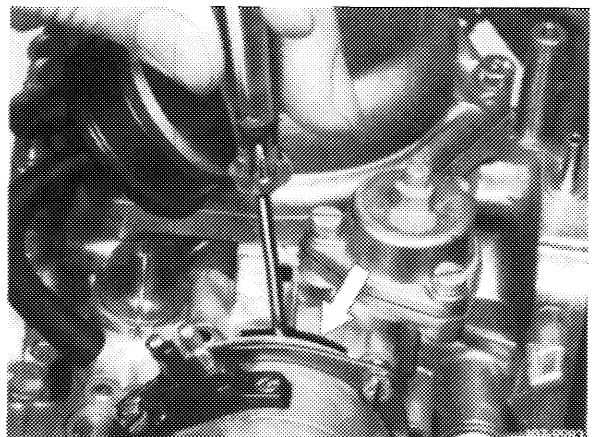

**Attention!**

Do not push beyond noticeable stop to prevent faulty measurements.

Release throttle valve lever, keep drive lever against stop. Choke sliding valve is pushed down by drive lever (86) and choke rod (85) rests on second-highest detent of fast idle cam (87) (pull-down position).

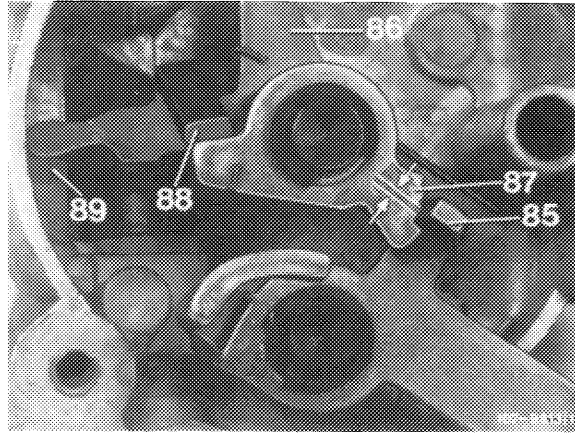

Adjust warm-up speed by adjusting connecting rod.

**Shortening = reduced speed**  
**Lengthening = increased speed**

**Note:** Adjustment of choke connecting rod by half a turn provides a change in speed of approx. 200/min.

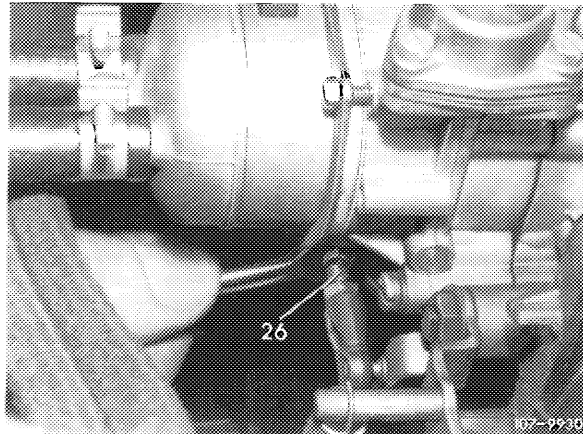

On carburetor version with warm-up speed adjusting screw (114), adjust warm-up speed by means of this screw.

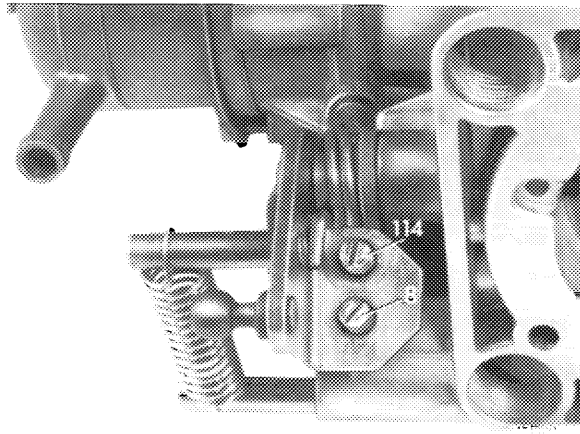

Check warm-up CO value and adjust, if required.

### Model 115, choke housing version 1

**Note:** Dimension "a" = 8.5–9.5 mm, permissible adjusting range of adjusting screw (96) 1 mm.

Adjust screw (96) within permissible adjusting range until specified warm-up CO value of 6–7 % CO is attained.

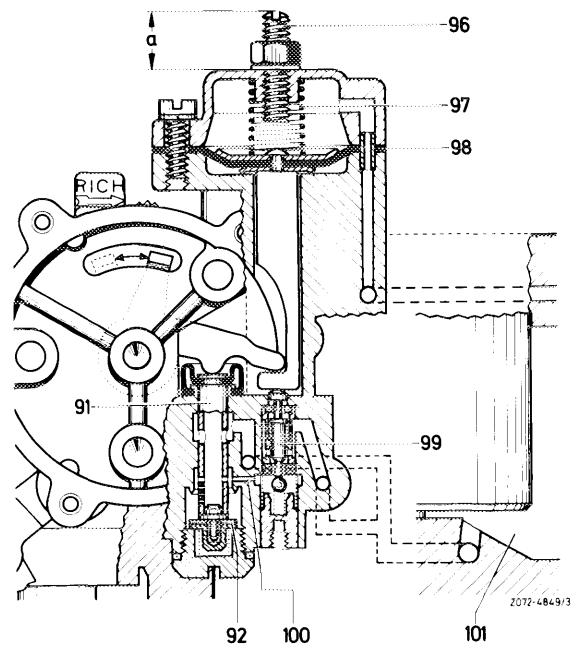

**Screwing out** = leaner

**Screwing in** = richer

If the specified warm-up CO value is not attained, install a choke housing of the latest version with warm-up CO adjusting screw (07.2–149).

124 Warm-up CO adjusting screw

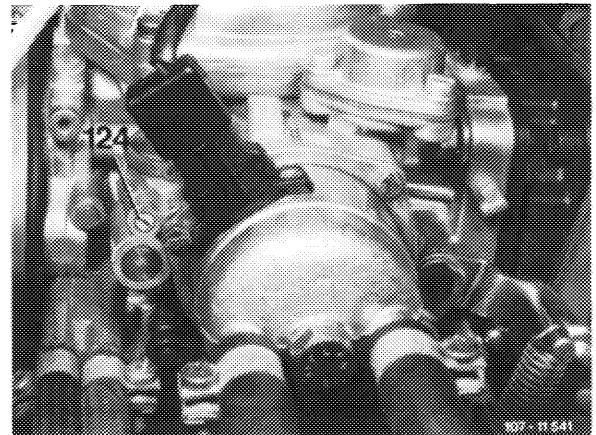

### Model 115, choke housing version 2 and model 123

Set to specified warm-up CO value (model 115 6–7 % CO, model 123 5–6 % CO) by means of adjusting screw (124).

**Screwing out** = leaner

**Screwing in** = richer

Let drive lever go back, accelerate for a short moment, check warm-up speed and warm-up CO value once again and readjust, if required.

Make EGR and air injection again operative.

124 Warm-up CO adjusting screw

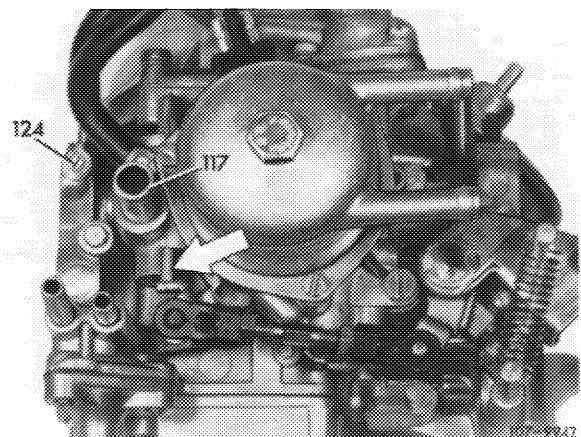



8 Check heater flap shaft for easy operation and wear.

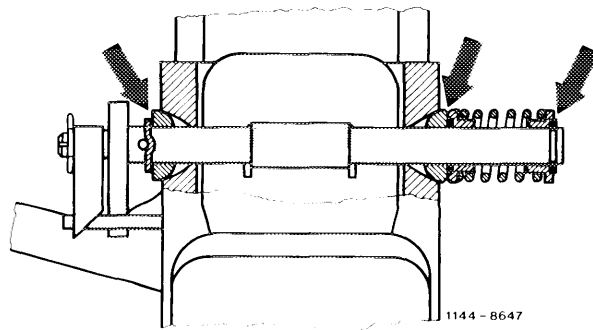

**Note:** Do not lubricate heater flap bearing with wide thrust washer (arrow), since bearing cups are made of sintered ceramic material and are therefore not requiring any service.

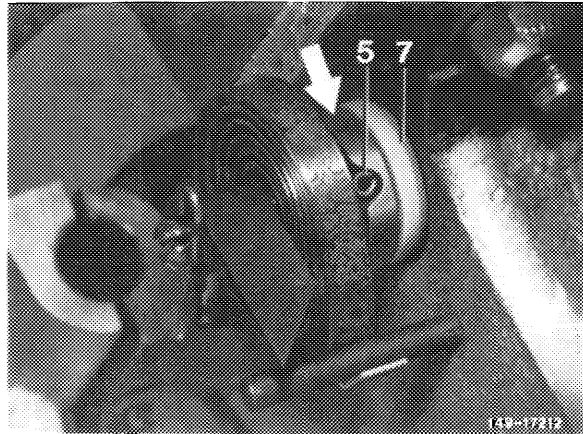

9 Check preheating of intake air.

**a) Engine 115**

With engine at operating temperature intake air temperature above approx. +35 °C, pull off cold air hose (2). Air flap (3) should be in position "cold air", that is, the warm air duct (4) should be locked by flap.

- 2 Cold air duct
- 3 Air flap in position "warm air"
- 4 Warm air duct

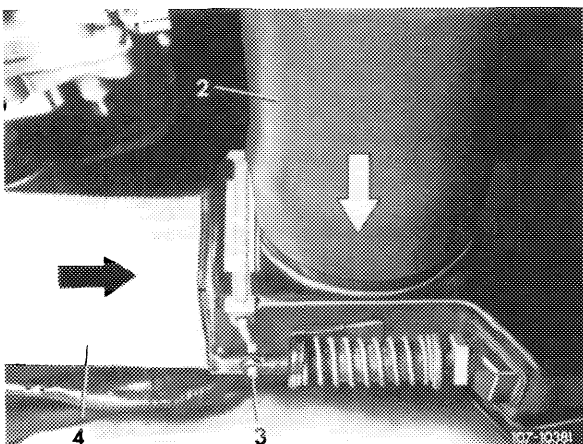
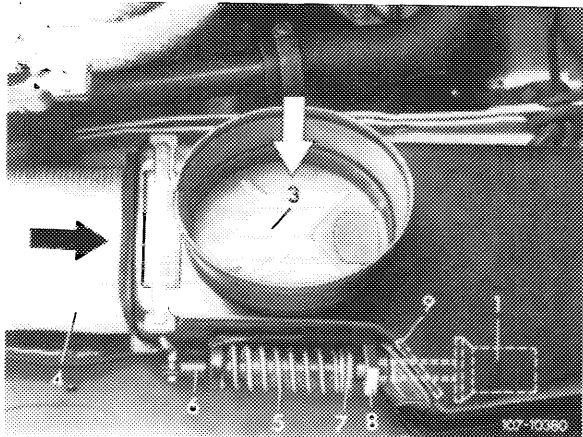

b) Engine 123

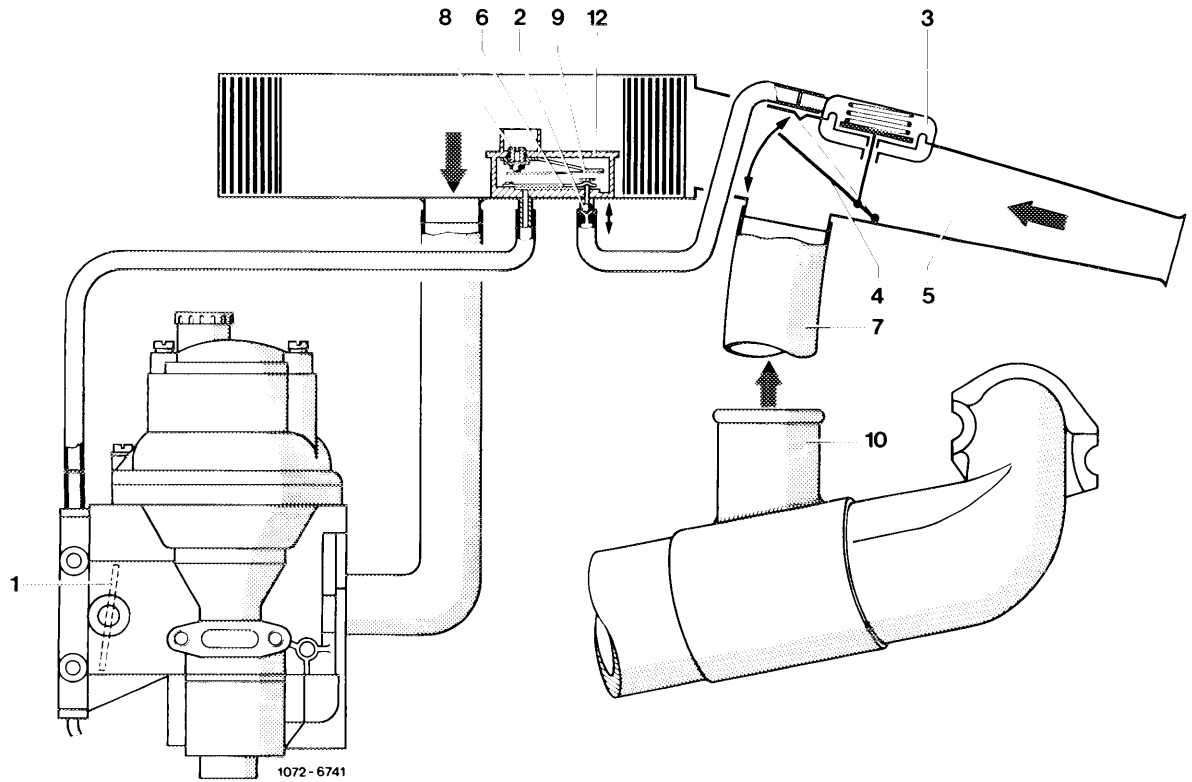

- |                       |                                      |
|-----------------------|--------------------------------------|
| 1 Throttle valve      | 7 Warm air duct                      |
| 2 Check valve         | 8 Secondary air duct                 |
| 3 Vacuum control unit | 9 Bimetallic spring                  |
| 4 Air flap            | 10 Warm-up scoop on exhaust manifold |
| 5 Cold air duct       | 12 Temperature regulator             |
| 6 Bimetallic spring   |                                      |

With engine at operating temperature, intake air temperature above approx. +40 °C, pull off warm air hose (7). Air flap (4) should be in position "cold air", that is, the warm air duct (7) should be locked by flap.