

Replacement

- 1 Remove choke housing.

For this purpose, pull off double plug (84) for heating choke cover and, if required, also vacuum line on pull-down cover.

Unscrew fastening screws (24) and put choke cover with connected coolant hoses aside.

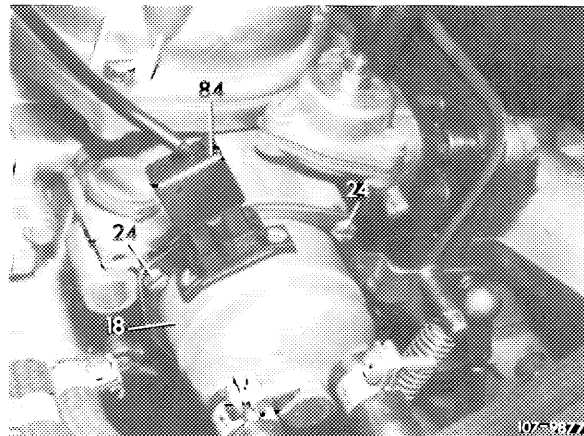

On vehicles in national version with float chamber external venting (161), pull off hose on choke housing.

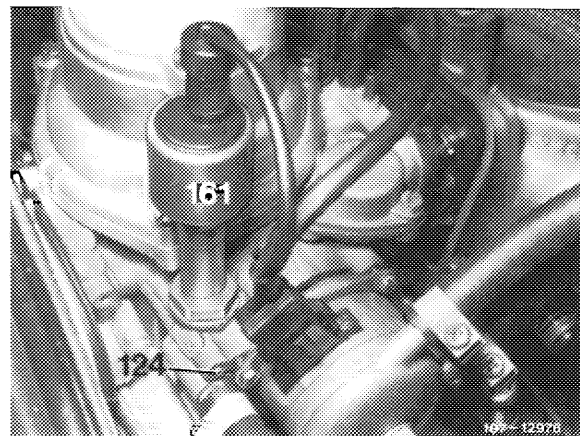

Disconnect connecting rod (26) on choke rod (85). Unscrew fillister head screws (17) and remove choke housing (16).

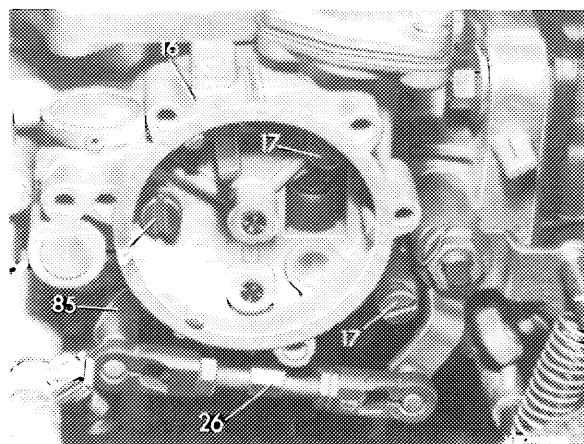

2 Remove locks (166, 167). Remove choke rod (85), fast idle cam (87), drive lever (86) together with restoring springs and spring retainer (105).

Replace drive lever according to condition.

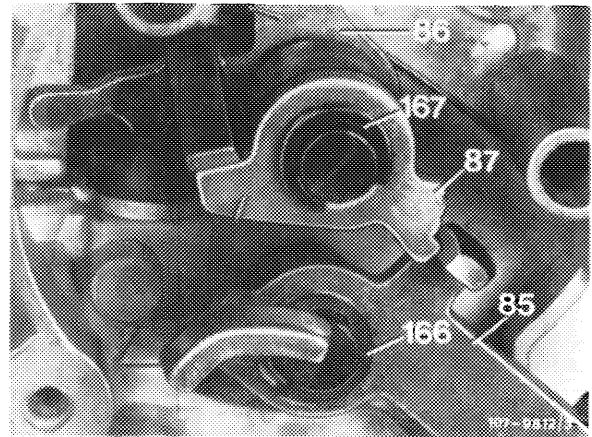

3 Place spring retainer (105) and restoring spring (169) on drive lever (86) and slip on bearing shaft in choke housing.

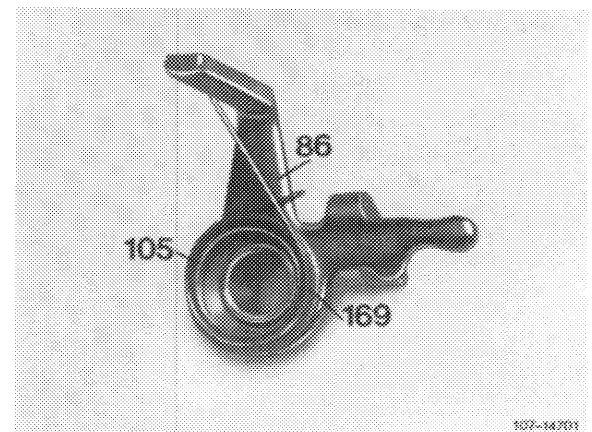

4 Tension restoring spring (169).

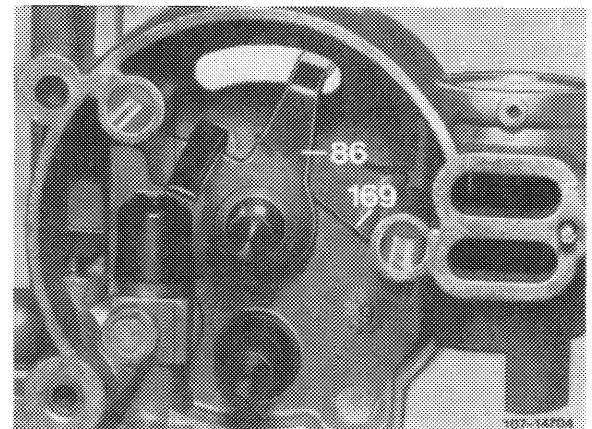

5 Attach restoring spring (168) to fast idle cam (87) and slip fast idle cam with restoring spring on bearing shaft. Connect restoring spring (168) to drive lever (86).

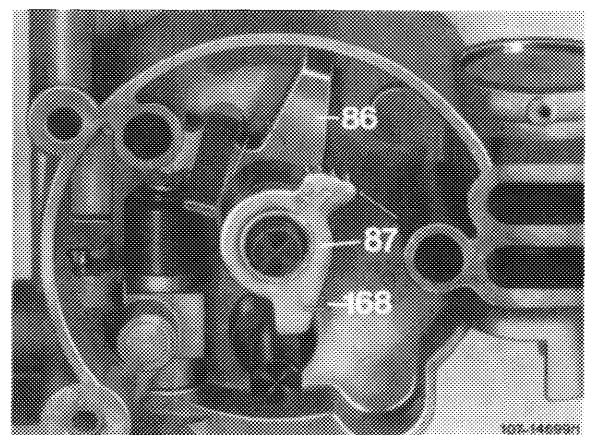

6 Turn fast idle cam (87) to the left until cam rests against underside of driver (88). Mount lock (167), install choke rod (85) and mount lock (166).

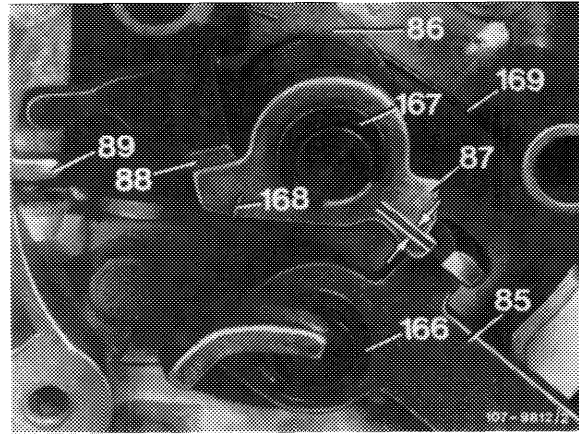

7 Slip protective sleeve (171) over driver.

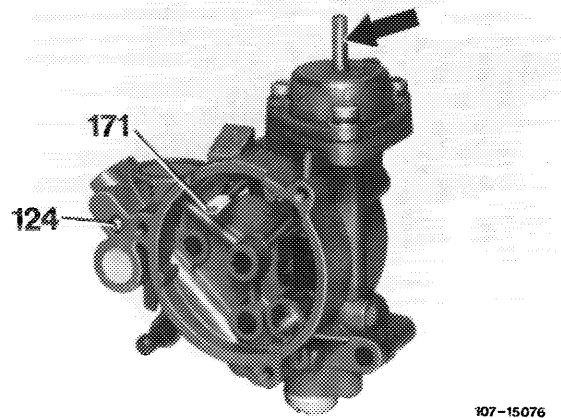

8 Check position of fast idle cam in relation to choke rod and adjust, if required.

Check whether driver (arrow) is at **right angle** in relation to face of choke housing and bend accordingly, if required.

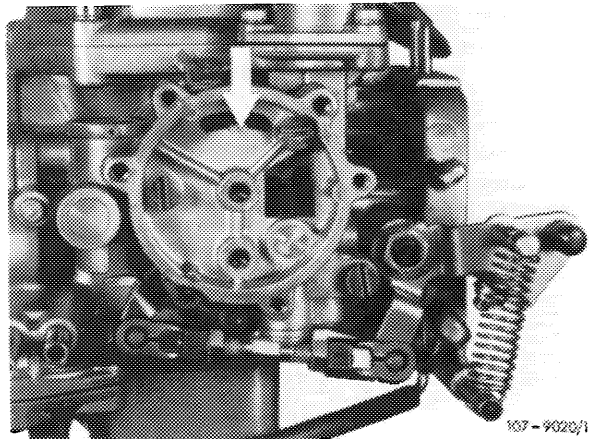

Pulldown position

Push diaphragm rod (89) upwards against stop and push drive lever (86) to the left (drive lever should rest against diaphragm rod). Choke rod (85) should rest approx. in center (arrows) of second-highest detent (pulldown position) of fast idle cam (87). Bend driver (88) accordingly, if required.

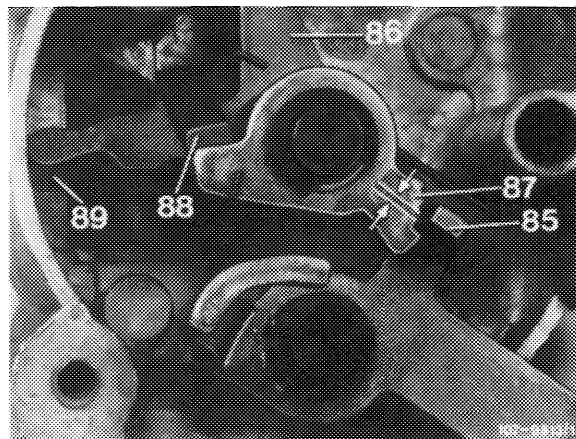

Full start position

Push drive lever (86) to the left up to stop (choke slide valve completely pushed in). In this position, choke rod (85) should rest on highest detent of fast idle cam (87) for a length of min. 0.5 mm. Rebend driver (88) accordingly, if required.

Note: If driver (88) has been bent as required, check pulldown position again.

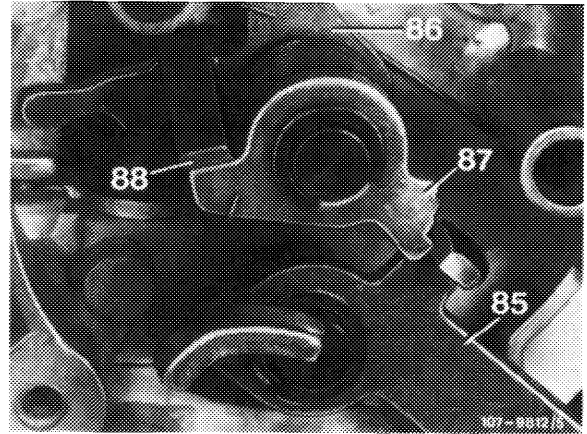

Idle speed position

Push drive lever (86) completely to the right against stop and push choke rod (85) completely up. Choke lever should move into idle speed position (arrow) and should not rest on detent segment of fast idle cam (87). Refinish detent segment accordingly, if required.

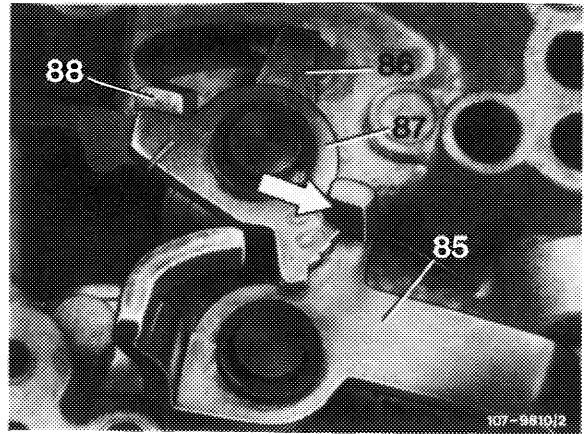

9 Install choke housing and choke cover in vice versa sequence (item 1). Use new gaskets.

Attention!

Do not forget insulating gasket between choke cover and choke housing.

10 Adjust choke (07.2–125).