

Special tool

Clamp

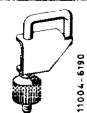

000 589 40 37 00

Removal

1 Remove choke cover.

For this purpose, pinch coolant hoses for heating choke cover with a clamp and pull from choke cover (18).

Pull off double plug (84), unscrew fastening screws (24) and remove choke cover together with insulating gasket.

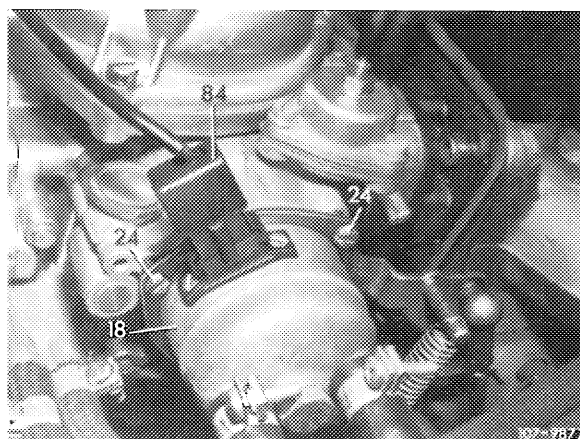

2 Remove choke housing.

On vehicles in national version with float chamber external venting (161), pull off hose on choke housing.

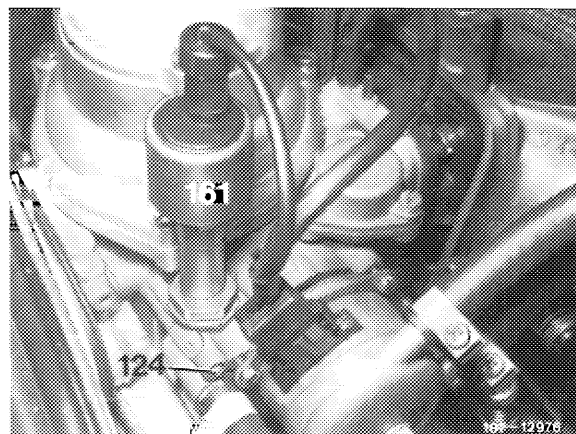

If required, pull off vacuum line on pulldown cover.

Disconnect connecting rod (26) on choke rod (85). Unscrew fillister head screw (17) and remove choke housing (16).

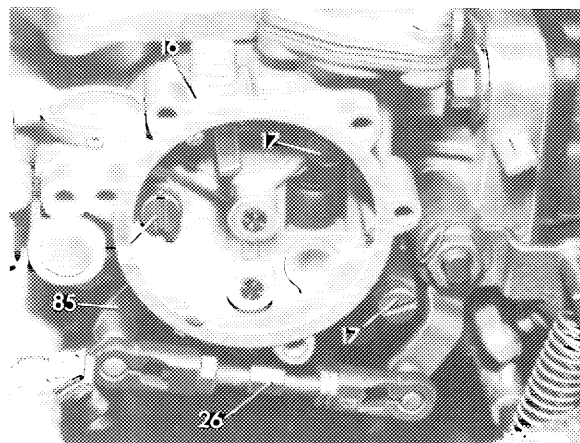

Checkup

3 Check choke cover mark and make new mark, if required (calibration of bimetallic spring in choke cover).

For this purpose, choke cover should have a test temperature of +20 °C. Place choke cover with insulating gasket on choke housing and turn slowly to the right until choke rod (85) rests approximately in center (arrows) of second-highest detent (pulldown position) of fast idle cam (87).

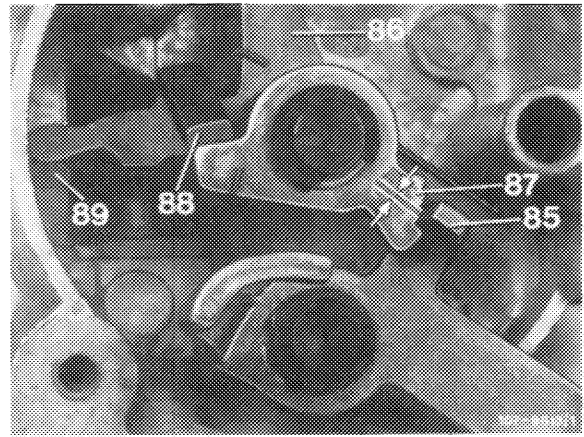

In this position, check choke cover mark (arrow) and punch in new mark, if required. Remove old marking notch on choke cover.

Note: To prevent faulty calibration, repeat this check-up.

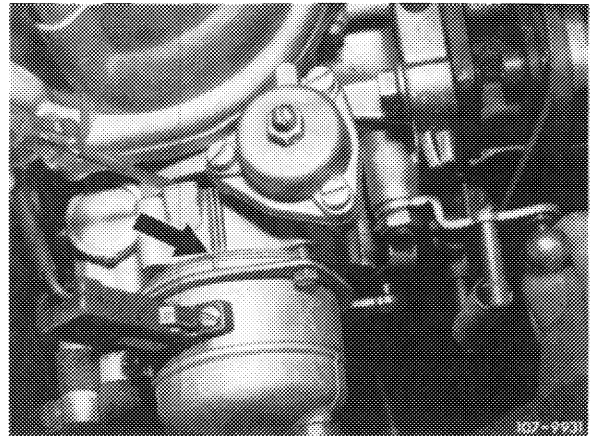

Installation

4 Install choke housing and choke cover in vice versa sequence (item 1 and 2). Use new gasket.

Attention!

Do not forget insulating gasket between choke cover and choke housing.

5 Adjust choke (07.2...125).