

07.6—250 Removal and installation of air pump

Federal and California version model year 1977/78

Removal

- 1 Compress hose clip on contoured hose with combination pliers and push approx. 2 cm to the rear. Pull contoured hose from connection of air pump.
- 2 Loosen nut (1) and fastening screws (2 and 3) and screw out. Remove tensioning screw (4).
- 3 Remove V-belt and air pump.

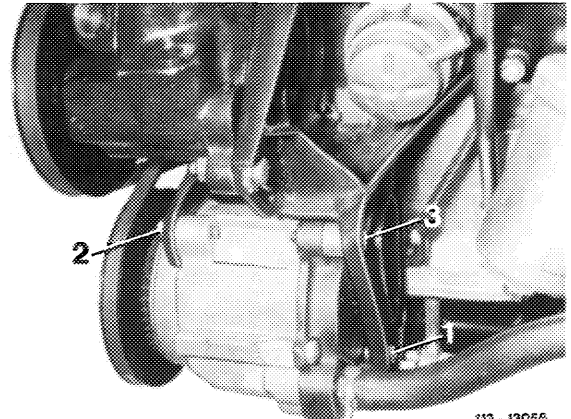

Installation

- 4 For installation proceed vice versa.

Note: The V-belt is correctly tensioned if it can be resiliently pushed down under energetic thumb pressure.

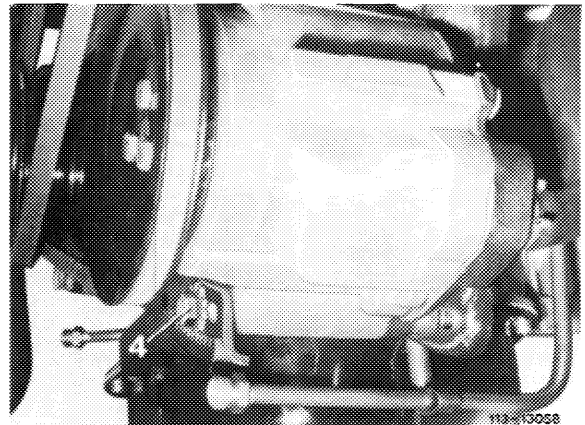

G. Fuel evaporation control system

The fuel evaporation system has been installed to improve emission characteristics which have nothing to do with engine combustion.

Function diagram

- 1 Expansion tank
- 2 Valve system
- 3 Fuel tank
- 5 Carburetor with vent valve
- 6 Charcoal canister

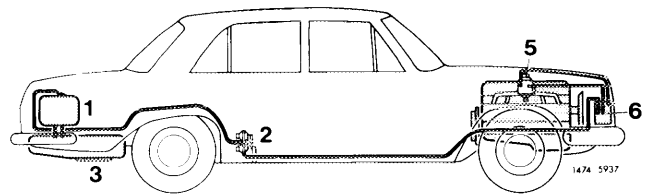

Components of fuel evaporation system:

Valve system

The valve system is mounted under vehicle at level of rear legroom.

The valve system comprises three valves:

1. Negative vent valve
2. Pressure relief valve
3. Positive vent valve

- 1 Protective box
- 3 Valve system

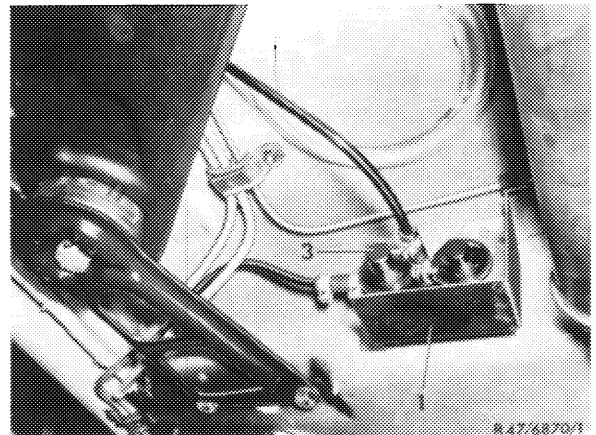

The **negative vent valve** opens at a low overpressure. Evaporation vapors are flowing via negative vent valve (1, direction B) in a line to charcoal canister.

The **pressure relief valve** is a safety valve and opens in the event of an overpressure in fuel evaporation system. The fuel vapors are vented directly to the atmosphere.

The **negative vent valve** opens in the event of an underpressure (vacuum) caused when the fuel tank is cooling down.

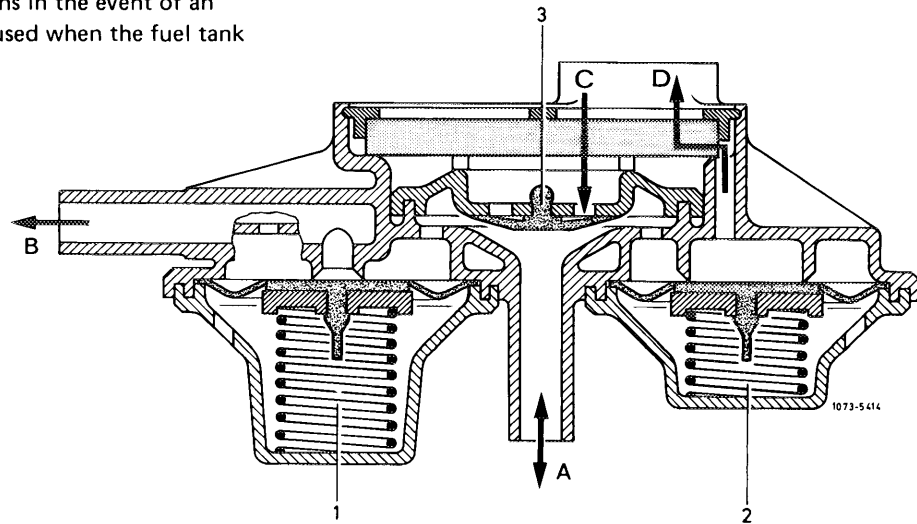

- 1 Negative vent valve
- 2 Pressure relief valve
- 3 Positive vent valve
- A To valve/to expansion tank
- B To charcoal canister
- C Fresh air inlet
- D Outlet pressure relief valve

Charcoal canister

The fuel evaporation vapors from fuel tank and from float chamber are stored in charcoal canister and are drawn off again when driving.

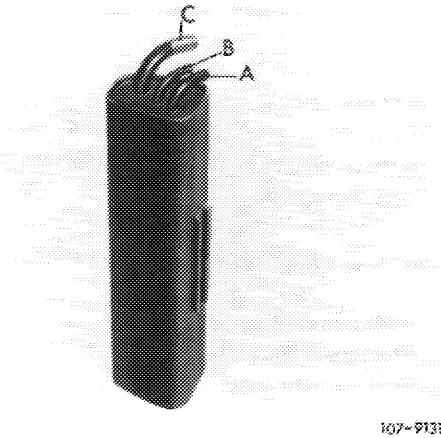

- A Connection tank vent
- B Connection purge valve
- C Connection float chamber positive vent valve

Operation

The fuel evaporation vapors from fuel tank and from carburetor float chamber are stored in charcoal canister when the engine is stopped, and they are drawn from charcoal canister via carburetor, when the engine is running in dependence of the throttle valve position.

The fuel evaporation vapors from fuel tank are routed directly into charcoal canister.

The fuel evaporation vapors from float chamber are stored in charcoal canister only when the engine is stopped and the valve is open.

At idle speed and with the engine stopped the float chamber vent valve is lifted by the regulating linkage. The valve toward charcoal canister is opened.

When the engine is running, the gases are drawn off into carburetor via connection "B" in dependence of the throttle valve position.

