

(J) (USA) starting 1978

Test values

Battery rest potential		approx. 12 V
Voltage ignition coil	Terminal 1	0.5-2.0 V
	Terminal 15	approx. 4.5 V
Input voltage	Pre-resistance	approx. 12 V
Ignition coil	Primary between terminal 1 and 15	0.33-0.46 Ω
	Secondary between terminal 1 and 4	7-12 Ω
Transmitter resistance between terminal 7 and 31 d		600 \pm 100 Ω
Transmitter coil with control line terminal 7 and ground		∞
Dwell angle	1500/min	58-77°
	5000/min	64-82°

Conventional tools

Voltmeter, ohmmeter, dwell angle measuring instrument, revolution counter

Digital tester e.g. made by Bosch, MOT 001.03

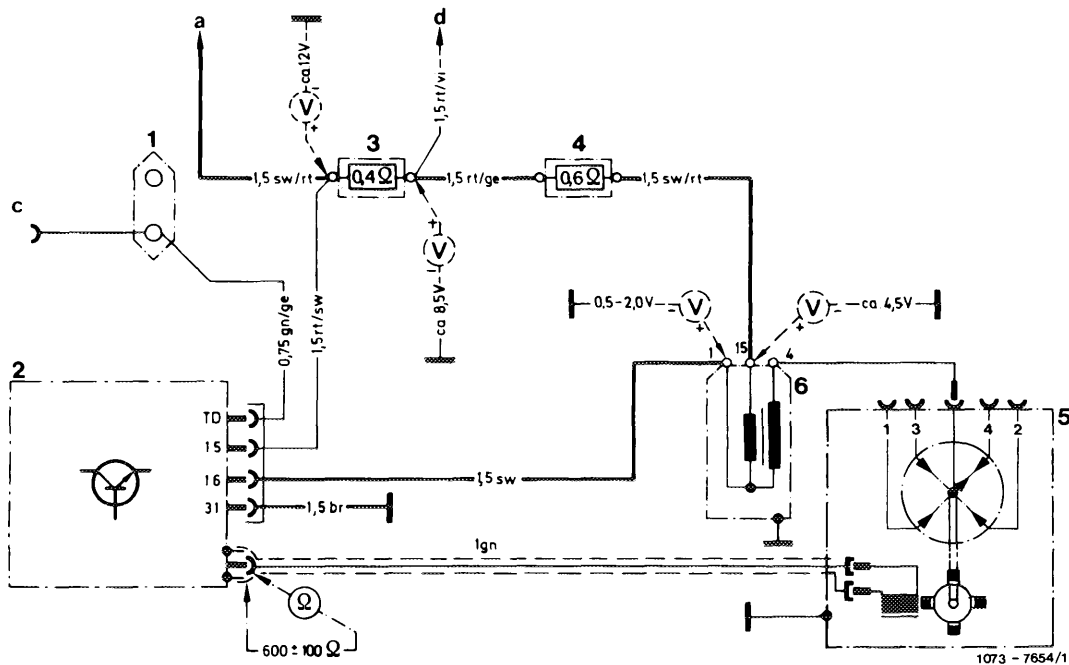

Wiring diagram breakerless transistorized coil ignition TSZ 4

- | | | |
|--------------------------|---|---------------------------------------|
| 1 Double cable connector | 4 Pre-resistance 0.6 Ω | a Ignition starter switch terminal 15 |
| 2 Switching unit | 5 Ignition distributor with transmitter section | c Diagnosis socket |
| 3 Pre-resistance 0.4 Ω | 6 Ignition coil | d Terminal 16 starter |

Note

In the event of complaints about misfiring, test high voltage end of ignition system first (spark plugs, ignition cable, spark plug socket).

If complaints refer to firing of engine, perform the following test on ignition system in addition to test at fuel end:

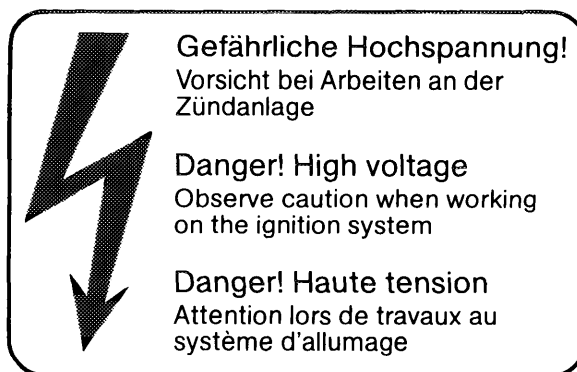

1154-9352

Visual checkup

Check electric screw connections and plug connections of ignition system for tight seat.

Voltage test

Note: With ignition switched on and engine stopped, a primary current of approx. 8 amps will continuously flow in this ignition system.

1 Input voltage on pre-resistance 0.4Ω
Cable color black/red:

Nominal value approx. 12 volts

2 Voltage on ignition coil at approx. 20°C :

Terminal 15 = approx. 4.5 volts

Terminal 1 = 0.5–2.0 volts

- a) If the value on terminal 1 is exceeded, the switching unit is defective and should be replaced.
- b) If the value at terminal 1 is attained, but no ignition voltage (ignition spark) is induced, test transmitter section in ignition distributor and secondary winding of ignition coil.

Resistance values ignition coil:

Primary winding terminal 15 to terminal 1
= $0.33\text{--}0.46 \Omega$

Secondary winding terminal 1 to terminal 4
= $7\text{--}12 \Omega$

Testing dwell angle

Note: The dwell angle cannot be adjusted. The test serves as an operational checkup of the switching unit (dwell angle control).

Connect dwell angle measuring instrument (connection similar to SI standard switching unit).

Nominal value at

Engine speed	Dwell angle
$1500 \pm 50/\text{min}$	$58\text{--}77^{\circ}$
$5000 \pm 50/\text{min}$	$64\text{--}82^{\circ}$

¹⁾ Perform test at 5000/min only if complaints refer to misfiring at high speeds.

If this value is not attained when measuring dwell angle, test ignition distributor transmitter section first. If transmitter section is in order, replace switching unit.

Testing ignition distributor transmitter section

Pull off control line of ignition distributor on switching unit and connect ohmmeter.

- 1 Test transmitter resistance between terminal 7 and 31 d.

Nominal value: $600 \pm 100 \Omega$

Note: On cold engine the ohm value should be in lower half, on warm engine in upper half of specified value.

- 2 Test transmitter coil including control line for ground connection.

Nominal value: terminal 7 – ground = ∞

- 3 Check transmitter section for mechanical damage. There should be an air gap between rotor and stator.

Note: If the transmitter section is defective, replace complete ignition distributor.

