

22–241 Subsequent installation of engine shock absorber

Tightening torques

		Nm
Screws for engine carrier to engine mount front	M 12	70
	M 10	40
Adjusting screw for front engine stop		130
Adjusting screw for rear engine mount		40

Special tools

Torque wrench with inserting ratchet,
1/2" square, 25–130 Nm

001 589 66 21 00



Torque wrench with inserting ratchet,
1/2" square, 40–200 Nm

001 589 67 21 00

Note

Vehicles with **automatic transmission** are provided with an engine shock absorber starting with chassis end number shown below:

Model	Chassis end number
123.020	072 171
123.023	088 968
123.043	000 761
123.083	Start of series

The engine shock absorber is located between left-hand engine mount (driving direction) and frame cross member (arrow).

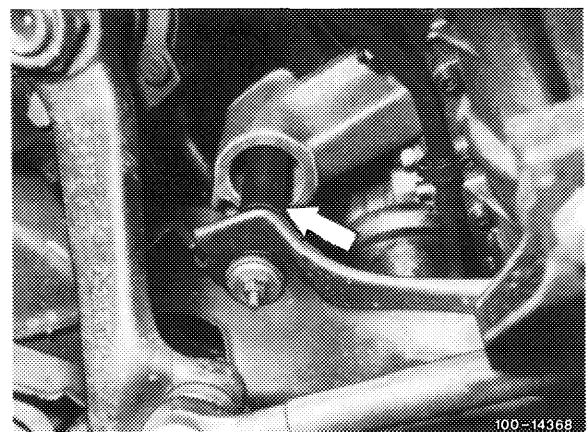

If vehicle with lower chassis end number is subject to complaints from customers about vibrations (spluttering), the engine shock absorber can be subsequently installed.

On vehicles with manual transmission the engine shock absorber may not be installed.

Components

Each	Designation	Part no.
1	Engine carrier	115 223 16 04
1	Engine shock absorber	123 240 05 48
1	Flange	123 241 00 45
2	Disc washer	115 241 07 12
1	Disc washer	123 241 02 12
2	Buffer	123 241 00 65
2	Buffer	123 241 03 65
2	Nut M 6	913002 006002
2	Combination screw M 6x15	914004 006001
1	Combination screw	123 990 02 12

Installation

- 1 Turn steering completely to the left or right.
- 2 Unscrew screws for engine carrier on engine mount from below.

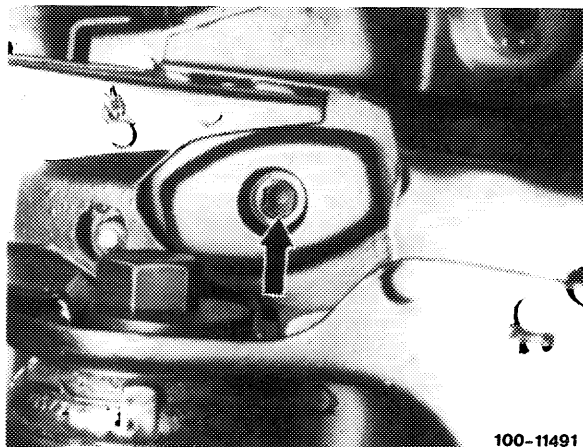

100-11491

3 Lift lock (30) on front engine stop, swivel away laterally and unscrew adjusting screw (31).

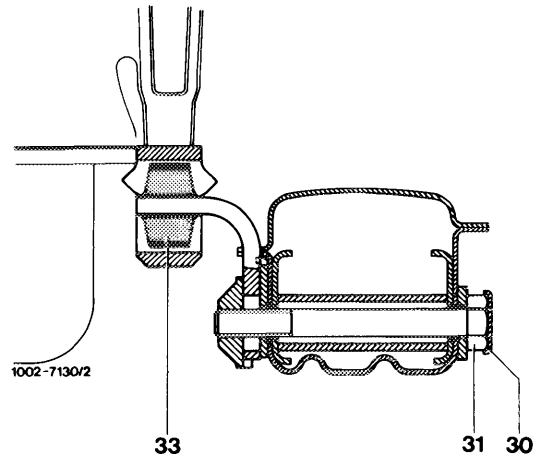

- 30 Lock
- 31 Adjusting screw
- 33 Engine stop

4 Unscrew support at exhaust end on transmission holder (arrow).

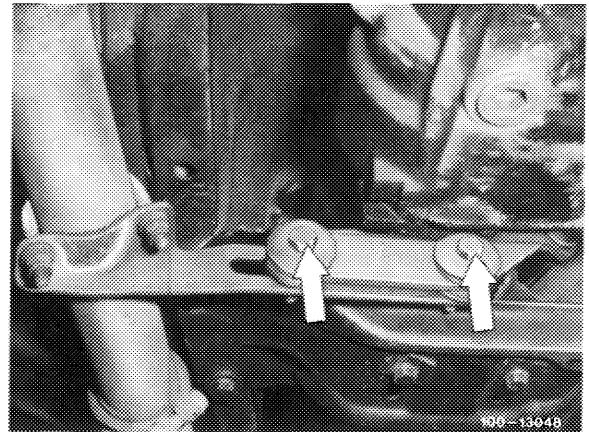

5 Loosen adjusting screw on rear engine mount (arrow).

6 Pull off rubber sleeve on air filter.

7 On vehicles with powersteering, draw oil from supply tank of power steering pump and unscrew or loosen oil hoses on power steering.

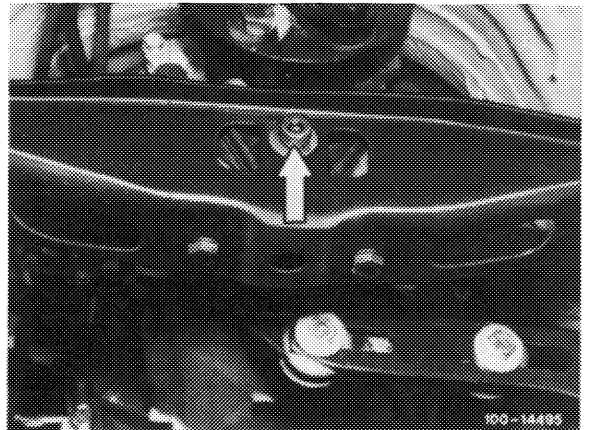

8 Lift engine with pitlift at oil pan.

Note: Use a wooden support to avoid damaging oil pan.

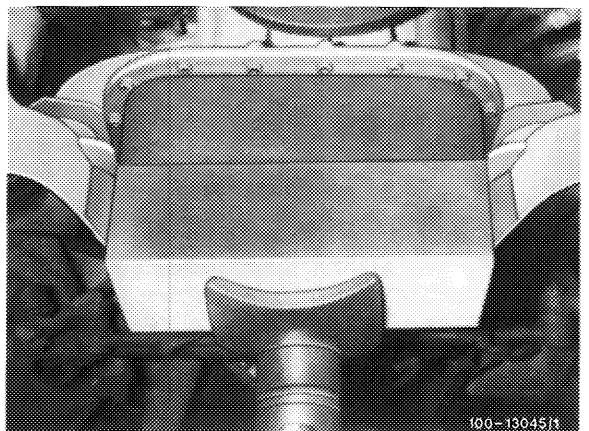

9 Unscrew lefthand engine carrier (driving direction) and remove.

10 Insert new engine carrier and screw down.

11 Lower engine; pay attention to position of shielding plate (arrow).



12 Position screws for engine carrier on engine mount and tighten to 70 Nm or 40 Nm.

Attention!

The threads in engine carriers were changed from M 12 to M 10. This engine carrier has also M 10 threads.

For this reason, the combination screw M 12 x 35 on older vehicles must be replaced by combination screw M 10 x 40.

13 Insert engine shock absorber with piston rod in downward direction from above through hole into engine carrier.

14 Lift engine shock absorber slightly from below and place upper disc washer (46) and upper rubber buffer (47) on piston rod.

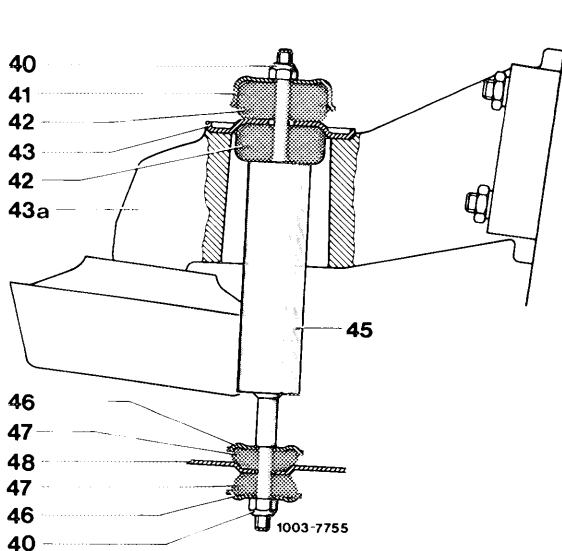

- | | |
|--------------------|--------------------------|
| 40 Nut M 6 | 45 Engine shock absorber |
| 41 Disc washer | 46 Disc washer |
| 42 Rubber buffer | 47 Rubber buffer |
| 43 Flange | 48 Frame cross member |
| 43a Engine carrier | |

15 Place piston rod into hole on frame cross member (arrow).

16 Position lower rubber buffer (47) and lower disc washer (46).

17 Screw-on lower nut (40).

18 Place lower rubber buffer (42) on engine shock absorber.

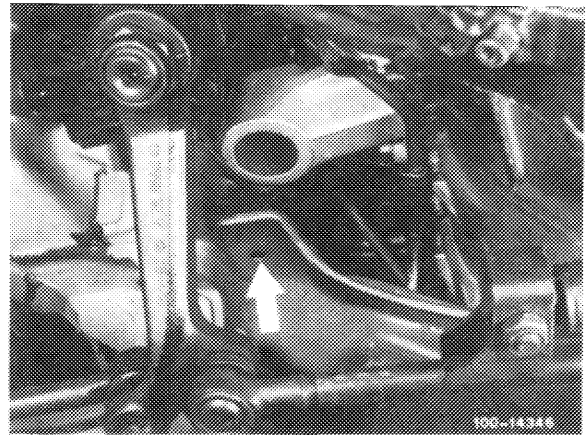

19 Place flange (43) on engine carrier (43a) and screw-on by means of the two combination screws M 6 x 15.

20 Position upper rubber buffer (42) and upper disc washer (41).

21 Position upper nut (40) and tighten. Apply counterhold to engine shock absorber.

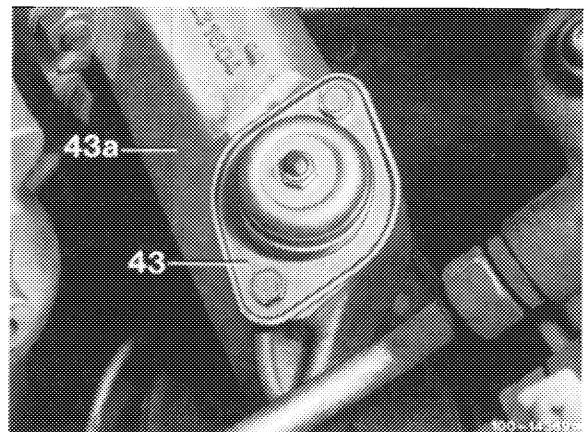

22 Tighten lower nut (40). For this purpose, apply counterhold to piston rod with a wrench at spot provided (arrow).

Attention!

The engine shock absorber should not rest against fastening bores.

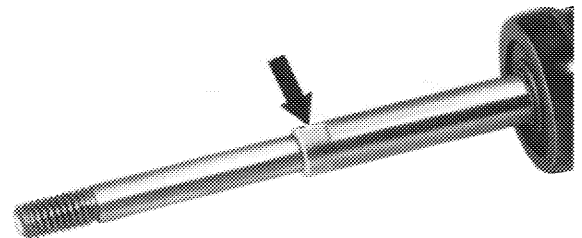

23 If on model 123.023 (AUS), (J), (S) and (USA) 1977/78 the pressure relief valve (74), rests against upper disc washer (41), turn pressure relief valve by approx. 45° in upward direction.

24 Move engine by lightly shaking crosswise manually.

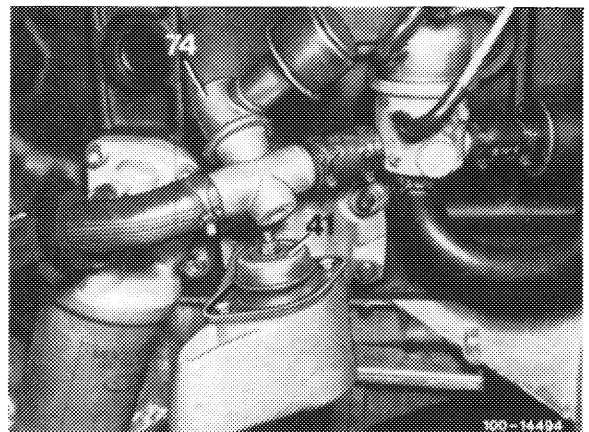

25 Tighten adjusting screw on rear engine mount to specified torque.

26 Insert adjusting screw on front engine stop and tighten to specified torque.

Place lock on screw head.

27 Screw support at exhaust end to transmission holder.

28 Slip rubber sleeve on air filter.

29 On vehicles with powersteering, connect hoses to powersteering.

Fill oil into supply tank, while turning steering several times to the left and right.