

A. Model 115

(AUS) starting October 1974

(J) starting August 1973

(USA) 1973/74

Note

The fuel tank is heated by high outside temperatures and by self-heating of the returning fuel. In a number of countries the resulting fumes cannot be vented into the atmosphere, as specified by pertinent laws.

For this reason, the vapors are drawn off from fuel tank while the engine is running by way of the crankcase breather into the combustion chambers, and they are stored in crankcase with the engine stopped.

Two lines lead from fuel tank to expansion tank (capacity 4.5 l). The expansion tank is located at the right in trunk.

Both lines serve as venting, overflow or discharge lines depending on position of fuel level in fuel tank, on fuel quantity and on temperature.

The connection for the positive and negative vent line of valve system (2) is at highest point of expansion tank.

The fuel evaporation control system comprises:

Fuel expansion tank (1)

Valve system (2)

Fuel tank (3)

Draw-off connection on crankcase (4)

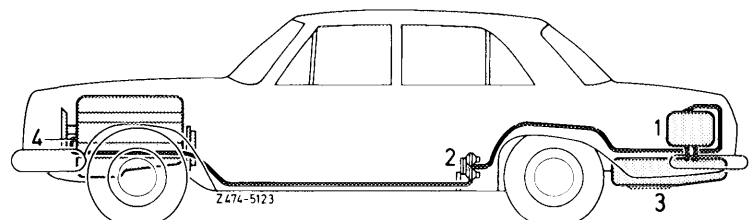

Valve system

The valve system is mounted underneath vehicle at level of rear legroom.

The valve system comprises three valves:

1. Negative vent valve
2. Pressure relief valve
3. Positive vent valve

- 1 Protective box
- 3 Valve system

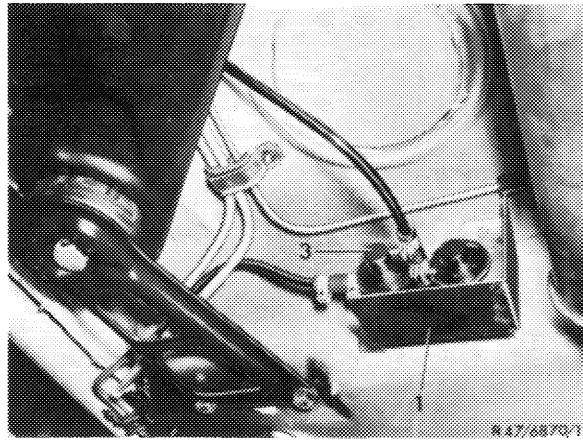

The **negative vent valve** (1) opens at a slight overpressure. The evaporation vapors are flowing through negative vent valve (1, direction B) into a line to engine. The line enters cylinder crankcase at pertinent connection.

The **pressure relief valve** (2) as a safety valve opens whenever an overpressure is established in fuel evaporation control system. The fuel vapors are discharged directly into the atmosphere.

The **positive vent valve** (3) opens in the event of a vacuum established by cooling down of fuel tank.

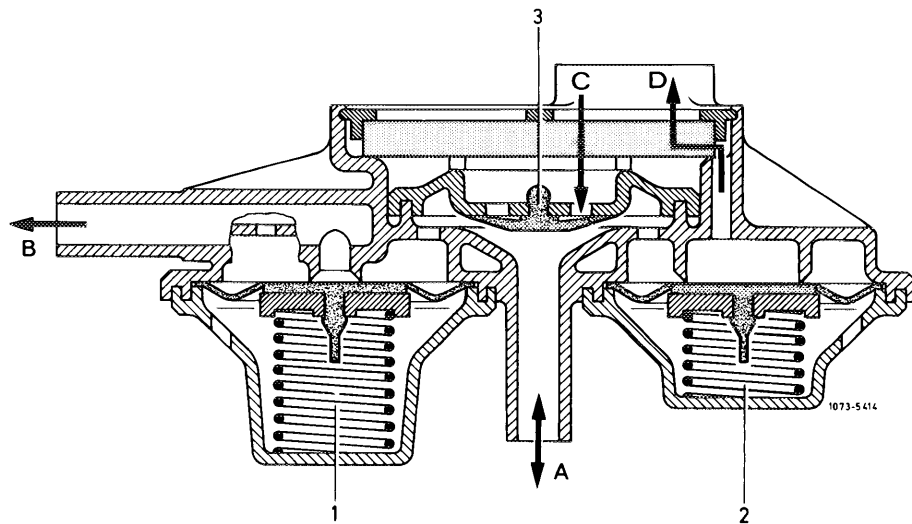

- 1 Negative vent valve
 - 2 Pressure relief valve
 - 3 Positive vent valve
- A To valve/to expansion tank
B To crankcase
C Fresh air inlet
D Outlet pressure relief valve

Model 115 fuel evaporation control system

- (AUS) starting October 1974
- (J) starting August 1973
- (USA) 1973/74
- 11 Hose clamp
- 50 Fuel expansion tank
- 51 Connecting pipe
- 52 Fuel hose
- 53 Negative vent line
- 54 Valve system
- 54a Cap
- 54b Filter
- 55 Negative vent line
- 56 Connecting pipe
- 57 Throttle (orifice)
- 58 Negative vent line
- 59 Closing plug
- 60 Ring piece
- 61 Sealing ring
- 62 Hollow screw

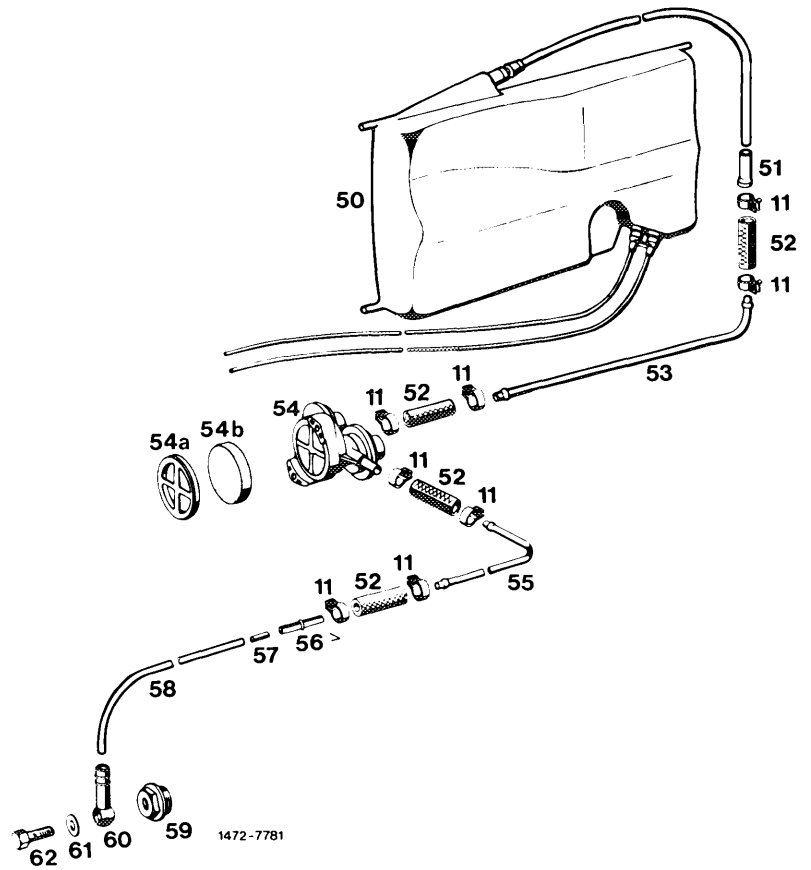

The fuel evaporation control system comprises: the fuel tank, the fuel expansion tank, the valve system, the charcoal canister, the float chamber positive vent valve and the draw-off connection on carburetor.

- 1 Expansion tank
- 2 Valve system
- 3 Fuel tank
- 5 Carburetor
- 6 Charcoal canister

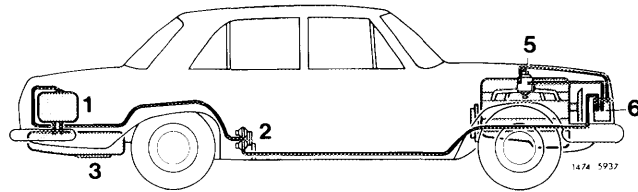

The fuel tank, the fuel expansion tank and the valve system are similar to the version already known.

With engine stopped, the fuel evaporation vapors from fuel tank and from float chamber of carburetor are stored in charcoal canister, and with the engine running they are drawn off from charcoal canister, depending on throttle valve position, by way of carburetor.

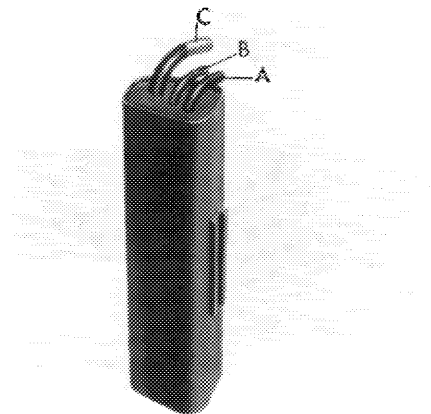

Charcoal canister

- A Tank vent connection
- B Draw-off connection
- C Float chamber-positive vent valve connection

The fuel evaporation vapors from fuel tank are routed directly into charcoal canister.

The fuel evaporation vapors from float chamber are stored in charcoal canister at idle and with engine stopped, when the valve is opened.

At idle speed and with engine stopped the float chamber positive vent valve is lifted by regulating linkage. The valve is opened in direction toward charcoal canister.

- A Tank negative vent connection
- B Draw-off connection
- C Float chamber-positive vent connection

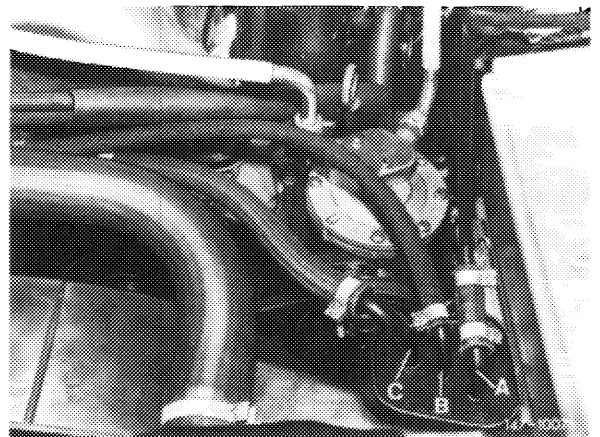

With the engine running, the vapors are drawn off into carburetor in dependence of throttle valve position.

B. Model 123

AUS 1977

J 1977/78

USA 1977

A fuel evaporation control system has been installed to improve emissions which are not connected with engine combustion.

Function diagram

- 1 Carburetor with float chamber positive vent valve
- 2 Valve system
- 3 Fuel tank
- 39 Charcoal canister

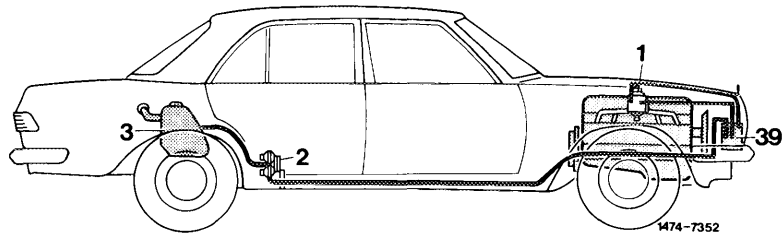

Components of fuel evaporation control system:

Valve system

The valve system is mounted underneath vehicle at level of rear legroom.

The valve system comprises three valves:

1. Negative vent valve
2. Pressure relief valve
3. Positive vent valve

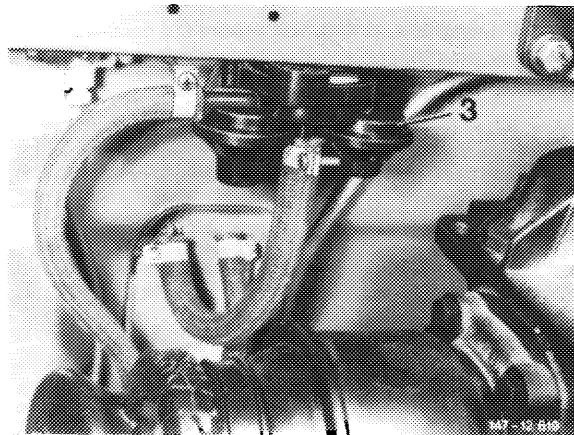

The **negative vent valve** opens at a slight overpressure. The evaporation vapors are flowing through negative vent valve (1, direction B) into a line to charcoal canister.

The **pressure relief valve** as a safety valve opens whenever an overpressure is established in fuel evaporation control system. The fuel vapors are discharged directly into the atmosphere.

The **positive vent valve** opens in the event of a vacuum established by cooling down of fuel tank.

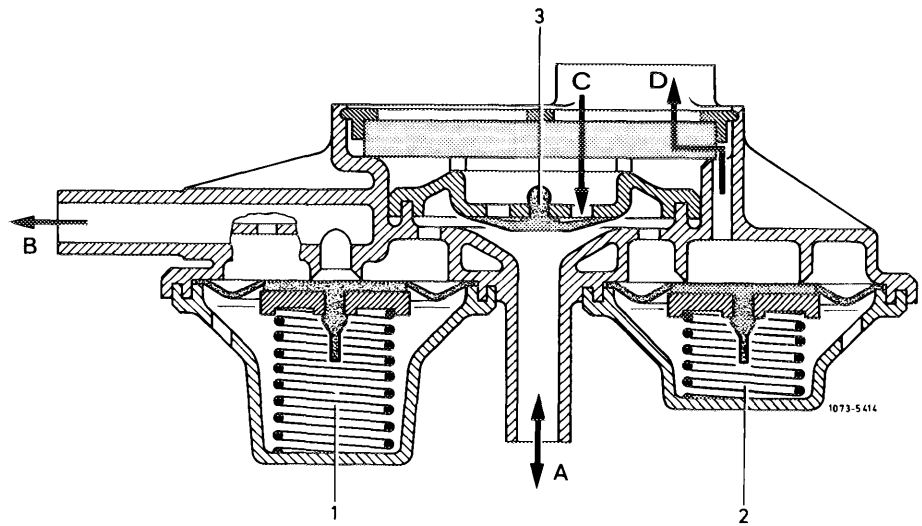

- 1 Negative vent valve
- 2 Pressure relief valve
- 3 Positive vent valve
- A To valve/to expansion tank
- B To charcoal canister
- C Fresh air inlet
- D Outlet pressure relief valve

Charcoal canister

The fuel evaporation vapors from fuel tank and from float chamber are stored in charcoal canister and are drawn off again while driving.

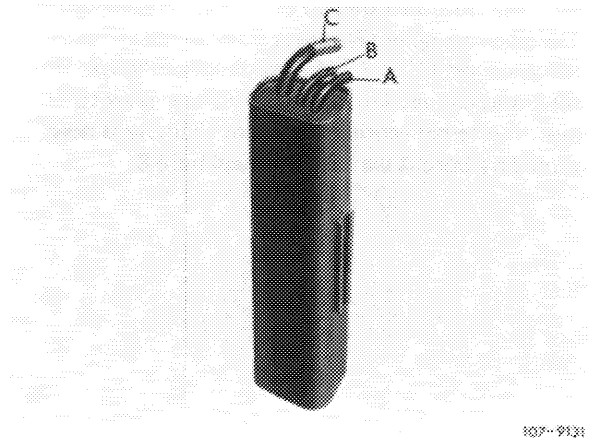

- A Negative tank vent connection
- B Draw-off connection
- C Float chamber-positive vent valve connection

Float chamber positive vent valve

The carburetor is provided with an electromagnetic float chamber positive vent valve. The valve is actuated when the ignition is switched on or off.

With the ignition switched off the electromagnet of the valve is deenergized. Compression spring (3) compresses valve plate (4) against upper valve seat (5). The float chamber evaporation vapors are now flowing from bore B across valve seat through connection C to charcoal canister.

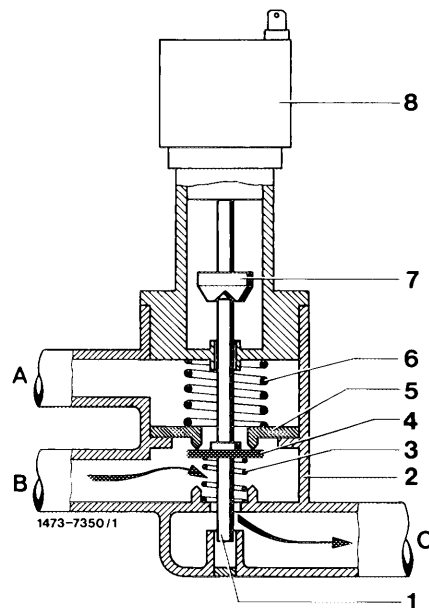

With the ignition switched on, the valve is energized. The electromagnet (7) moves downwards and pushes the valve rod (1) in downward direction. Valve plate (4) closes connection C. The carburetor is switched over to internal venting. The float chamber is now vented by bore A via valve through bore B.

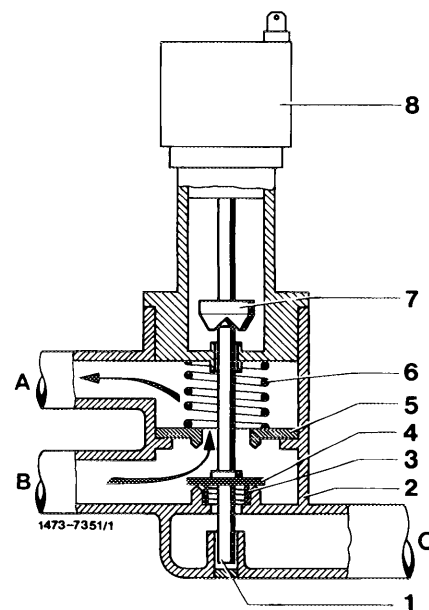

Draw-off connection on carburetor

To draw off fuel evaporation vapors from charcoal canister the carburetor is provided with a draw-off connection (118), which is provided with a vacuum in dependence of the throttle valve position.

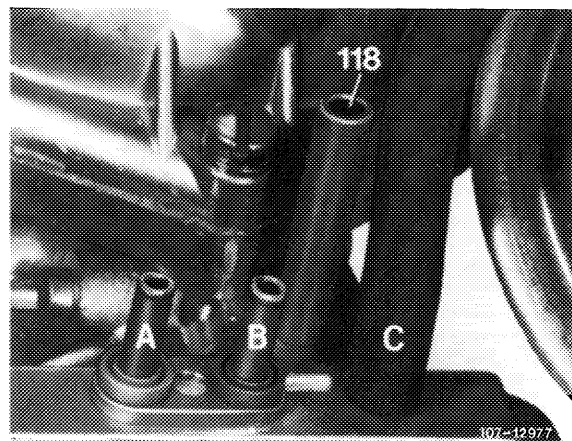

Operation

The fuel evaporation vapors from fuel tank are routed via valve system into charcoal canister. The fuel evaporation vapors from float chamber are flowing, with the engine stopped and the ignition switched off, via float chamber positive vent valve also into charcoal canister and are stored there. With the engine running, the fuel vapors in charcoal canister (39) are drawn off via draw-off connection (B) in dependence of the throttle valve position in carburetor.

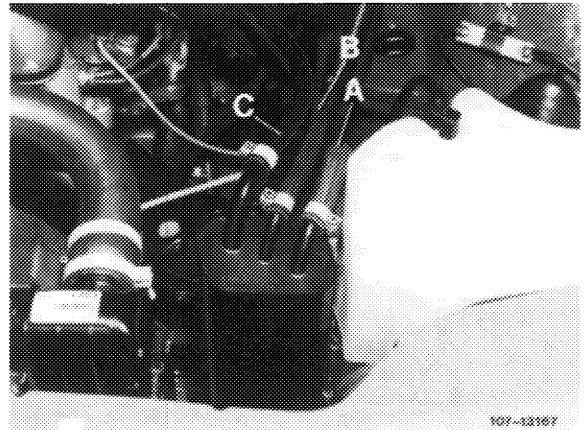

- A Tank negative vent connection
- B Draw-off connection
- C Float chamber-positive vent valve connection

(AUS) 1978–1980

(J) 1979–1981

(USA) 1978

A fuel evaporation control system has been installed to improve emissions which are not in connection with engine combustion.

- 1 Carburetor with positive vent valve
- 3 Fuel tank
- 4 Vent valve unit
- 5 Purge valve
- 39 Charcoal canister

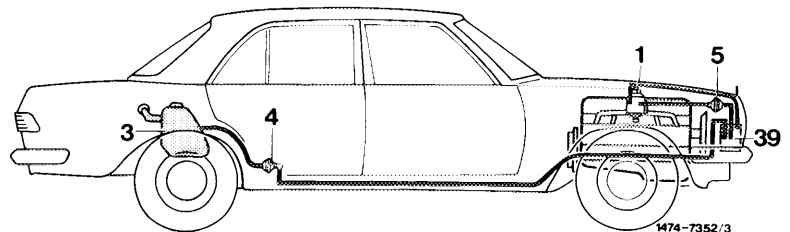

Vent valve unit (4)

The vent valve unit is mounted underneath vehicle at level of rear legroom and replaces the known valve system.

The unit comprises a negative vent valve and a positive vent valve.

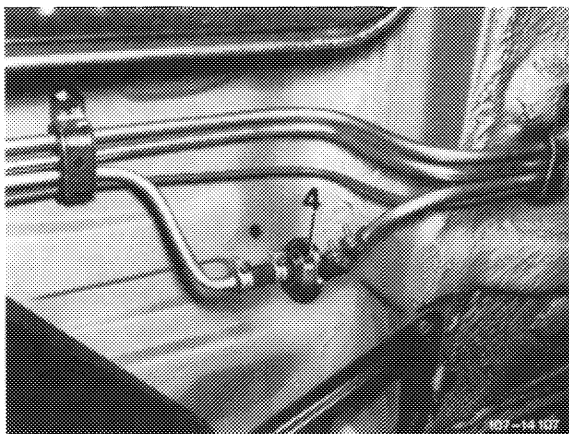

Charcoal canister

The fuel evaporation vapors of fuel tank, as well as those of float chamber are stored in charcoal canister and again drawn off while driving.

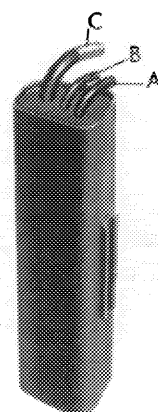

- A Tank negative vent connection
- B Draw-off connection
- C Float chamber-positive vent valve connection

107-9131

Purge valve (5)

The purge valve is located in purge line from charcoal canister to carburetor.

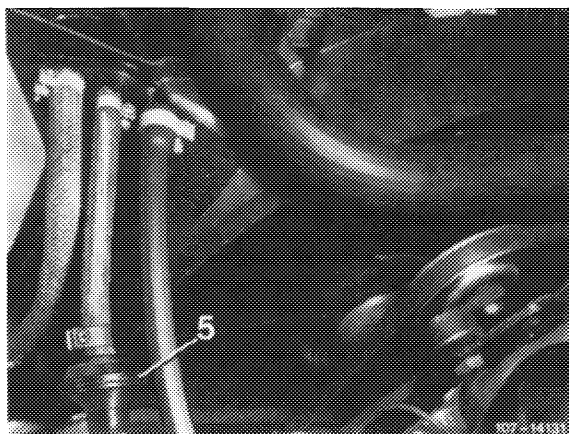

Float chamber positive vent valve (61)

The carburetor is provided with an electromagnetic float chamber positive vent valve. The valve is operated when the ignition is switched on or off.

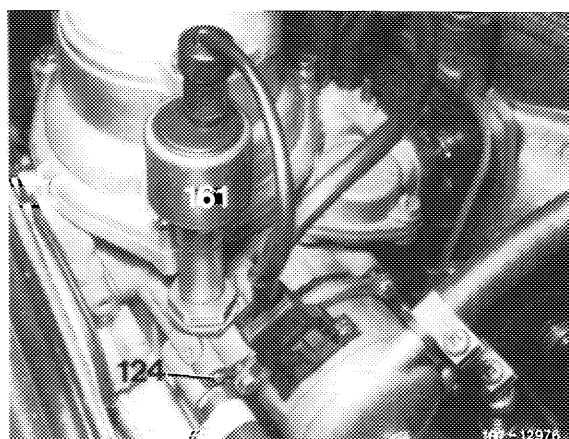

With the ignition switched off, the electromagnet of the valve is deenergized. Compression spring (3) compresses valve plate (4) against upper valve seat (5). The float chamber evaporation vapors are now flowing from bore B across valve seat through connection C to charcoal canister (external venting).

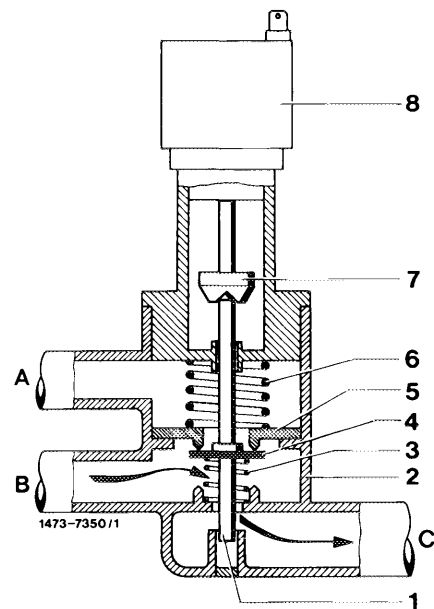

With the ignition switched on, the valve is energized. The electromagnet (7) moves downwards and pushes the valve rod (1) in downward direction. Valve plate (4) closes connection C. The carburetor is switched over to internal venting. The float chamber is now vented by bore A via valve through bore B.

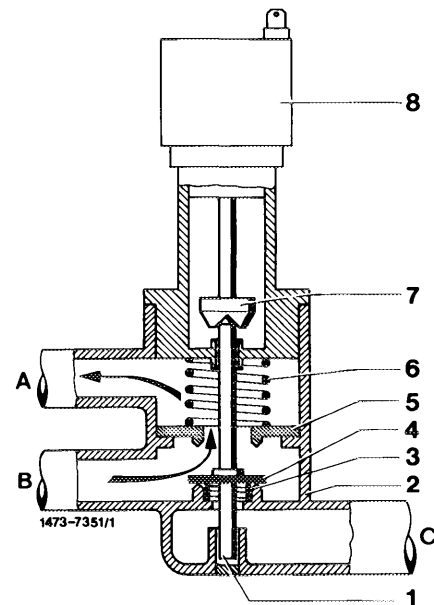

Draw-off connection on carburetor

To draw off fuel evaporation vapors from charcoal canister the carburetor is provided with a draw-off connection (118), which is provided with a vacuum in dependence of the throttle valve position.

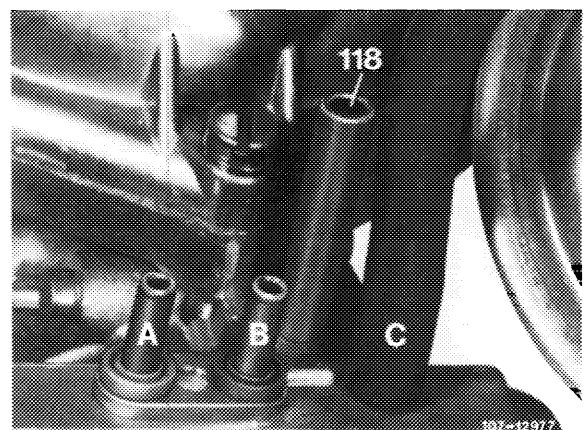

Fuel tank closing cap

To prevent increased overpressure in fuel tank, the fuel tank closing cap has been modified.

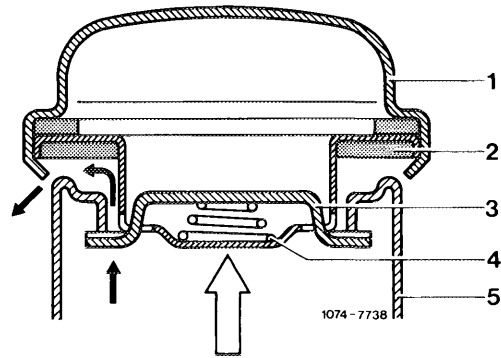

Operation

Evaporation control system

The vent valve unit (4) increases the pressure in fuel tank to 30–50 mbar. As a result, less fuel evaporation vapors will be able to escape from tank.

When the pressure in fuel tank attains 30–50 mbar, the negative vent valve (4) opens so that the fuel evaporation vapors can flow to charcoal canister, where they are stored with the engine stopped.

Vent valve unit open toward charcoal canister

- | | |
|-----------------------|--------------------------------|
| 1 Compression spring | 6 Positive vent valve |
| 2 Valve housing | 7 Connection |
| 3 Spring retainer | A Charcoal canister connection |
| 4 Negative vent valve | B Fuel tank connection |
| 5 Valve plate | |

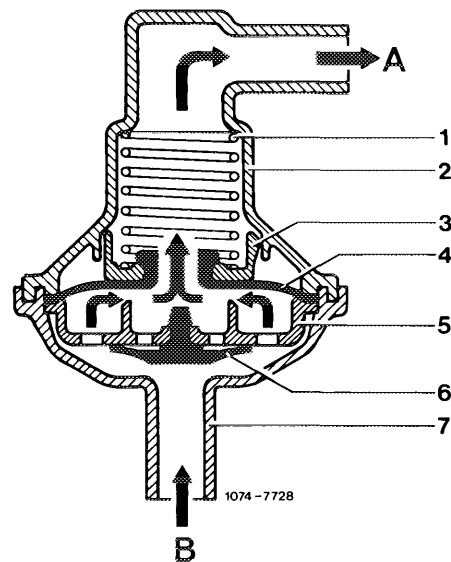

When the fuel is cooling down, the intake of air or fuel evaporation vapors from charcoal canister via positive vent valve (6) and starting at a vacuum of 1–16 mbar serves to balance the system. If the vacuum in fuel tank drops below 1 mbar, positive vent valve (6) will close.

If the pressure in fuel tank increases to above 0.1–0.3 bar as a result of a malfunction of evaporation control system, the fuel evaporation vapors can escape out of fuel tank through closing cap.

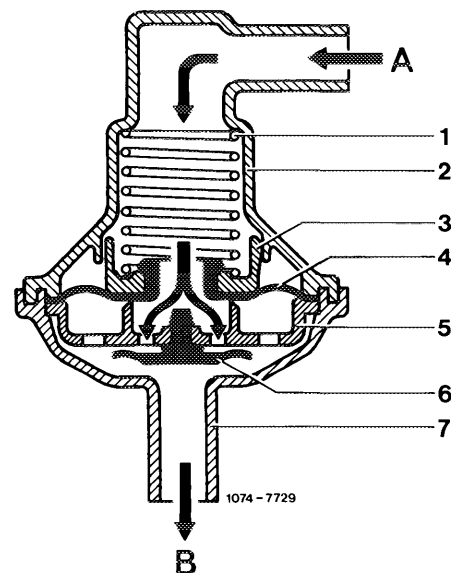

Vent valve unit open to fuel tank

With the engine stopped and the ignition switched off, the fuel evaporation vapors from float chamber are routed via float chamber positive vent valve to charcoal canister and are stored there.

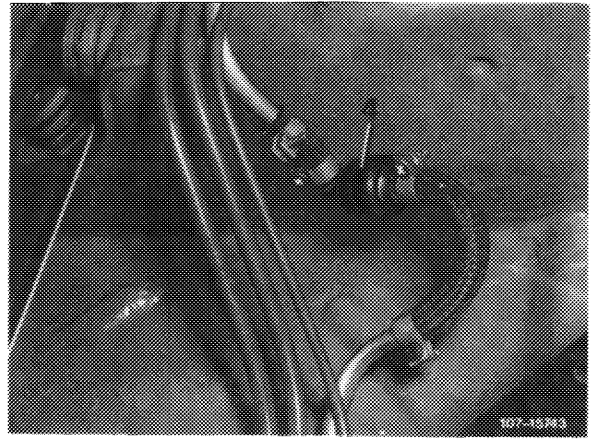

Purge system

The charcoal canister is connected to carburetor by means of a line which is in turn connected to purge valve (5).

If, with the engine running, the vacuum value of 30–50 mbar in purge line is exceeded, the purge valve will open. The fuel evaporation vapors stored in charcoal canister can be drawn off, depending on throttle valve position of carburetor.

Purge valve (open)

- | | |
|-----------------------|--------------------------------|
| 1 Compression spring | 5 Valve plate |
| 2 Valve housing | 6 Connection |
| 3 Spring retainer | A Throttle valve connection |
| 4 Negative vent valve | B Charcoal canister connection |

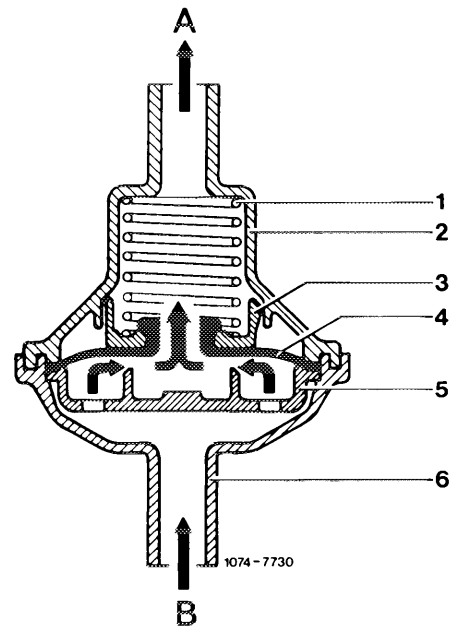

When the throttle valve is opened, the two purge holes in carburetor, which are entering a joint duct, are progressively exposed to the venturi vacuum. As a result, purging in lower partial range of engine is metered in such a manner that the driving characteristics are not influenced thereby.

At idle and during deceleration (throttle valve closed) the two purge bores are on atmospheric side of throttle valve. There is no purging of vapors in charcoal canister.

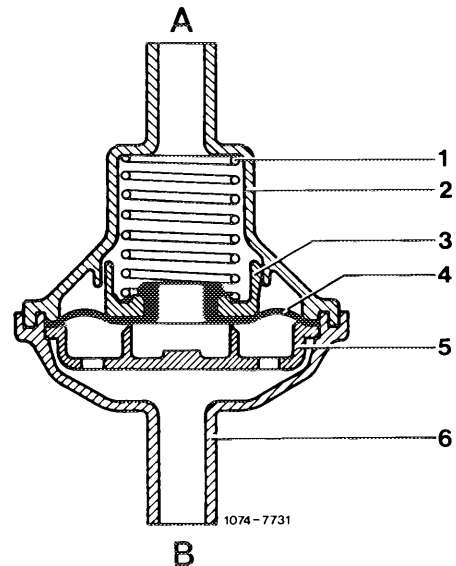

Purge valve (closed)

Fuel evaporation control system

- (AUS) 1977**
- (J) 1977/78**
- (USA) 1975-1977**

- 13 Hose clamp
 - 51 Fuel hose
 - 52 Negative vent line from fuel tank
 - 54 Fuel hose
 - 55 Valve system
 - 55a Cap
 - 55b Filter
 - 56 Negative vent line
 - 64 Negative vent line
 - 65 Charcoal canister
 - A Tank negative vent connection
 - B Carburetor connection
 - C Float chamber positive vent valve connection
- Arrow = carburetor draw-off connection

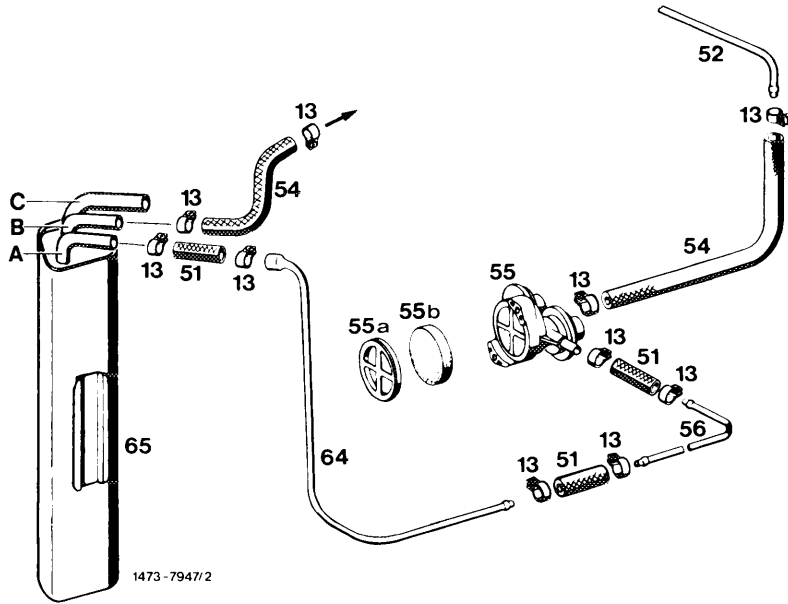

- (AUS) 1978-1980**
- (J) 1979-1981**
- (USA) 1978**

- 13 Hose clamp
 - 51 Fuel hose
 - 52 Negative vent line from fuel tank
 - 54 Fuel hose
 - 56 Negative vent line
 - 64 Negative vent line
 - 65 Charcoal canister
 - 66 Purge valve
 - 67 Vent valve unit
 - A Tank negative vent connection
 - B Draw-off valve connection
 - C Float chamber positive vent valve connection
 - D Vacuum line
- Arrow = carburetor draw-off connection

