

A. General function

Level control on rear axle is a hydropneumatic auxiliary suspension which engages automatically starting at a given deflection. On sedans, e.g., the level control will start approximately at a load of 2 persons on front seats and approx. 40 kg luggage in trunk. In each respective case, the control point for the loaded vehicle is the level which conforms to the design position of the respective vehicle model with the respective spring variant.

The level control system on rear axle operates hydropneumatically and comprises essentially the following three main components:

1. the suspension elements, comprising spring struts (5) and pressure reservoirs (4);
2. the pressure oil system, comprising pressure oil pump (1) and oil supply tank (2);
3. the control unit, comprising level controller (3) with pertinent actuating linkage.

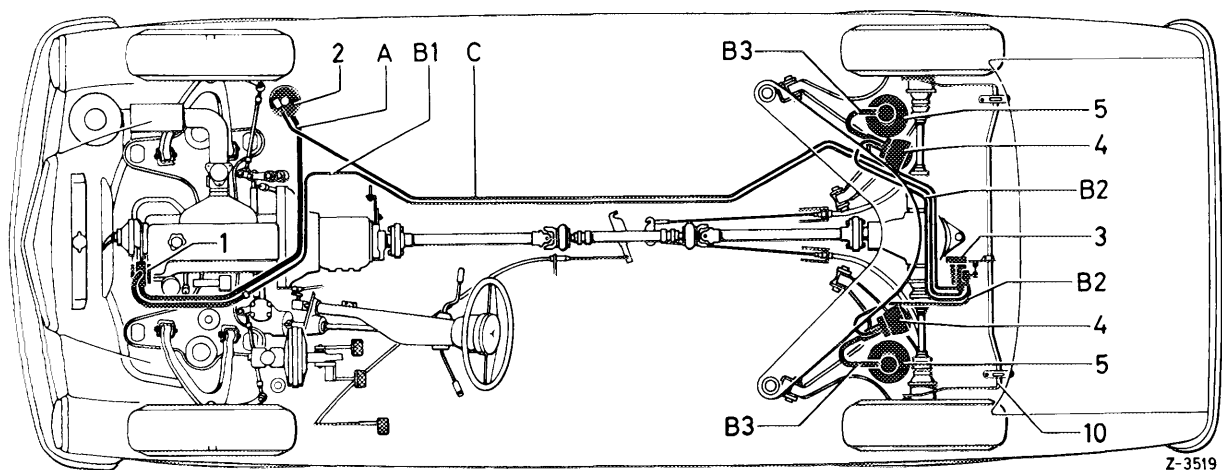

Z-3519

Layout sedans and coupes

- |                      |  |
|----------------------|--|
| 1 Pressure oil pump  | A Suction line oil supply tank – pressure oil pump     |
| 2 Oil supply tank    | B1 Pressure line pressure oil pump – level controller  |
| 3 Level controller   | B2 Pressure line level controller – pressure reservoir |
| 4 Pressure reservoir | B3 Pressure line pressure reservoir – spring strut     |
| 5 Spring strut       | C Return line level controller – oil supply tank       |
| 10 Torsion bar       |  |

**Layout sedans and coupes**

- 1 Pressure oil pump
- 2 Oil supply tank
- 3 Level controller
- 4 Pressure reservoir
- 5 Spring strut
- 6 Lever on torsion bar
- 7 Connecting rod
- 10 Torsion bar
- 18 Rear spring
- 19 Semi-trailing arm
- 26 Rear axle carrier
- A Suction line oil supply tank – pressure oil pump
- B1 Pressure line pressure oil pump – level controller
- B2 Pressure line level controller – pressure reservoir
- B3 Pressure line pressure reservoir – spring strut
- C Return flow level controller – oil supply tank

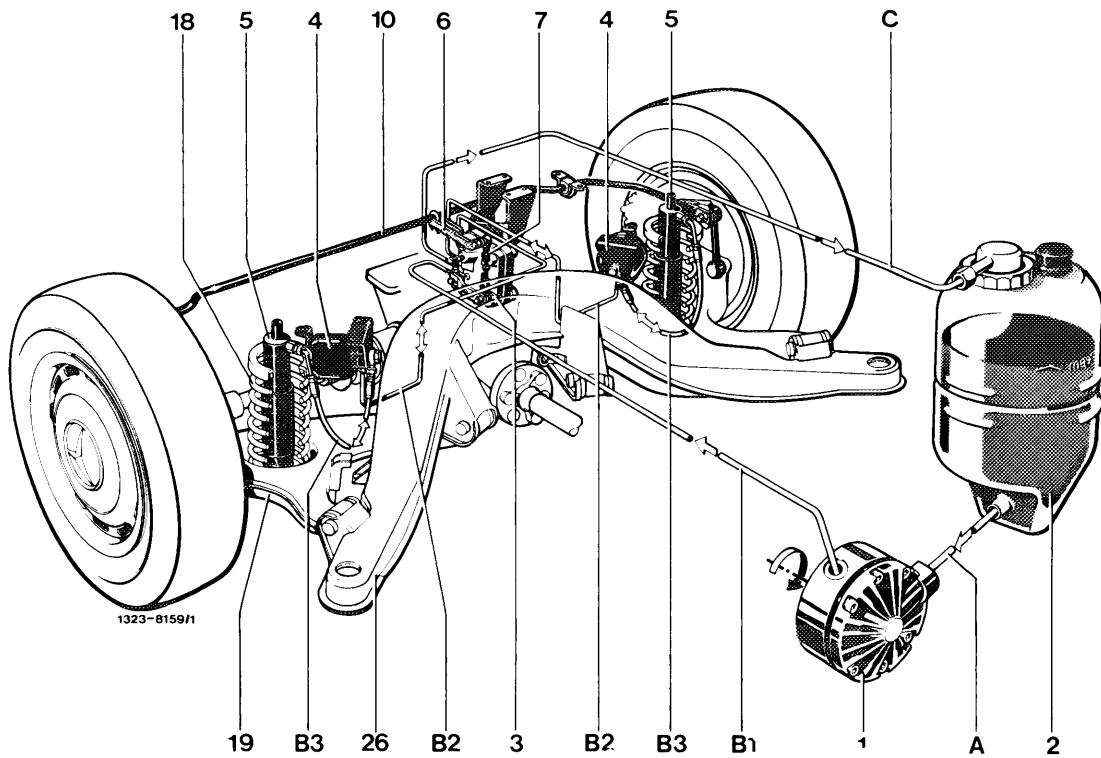
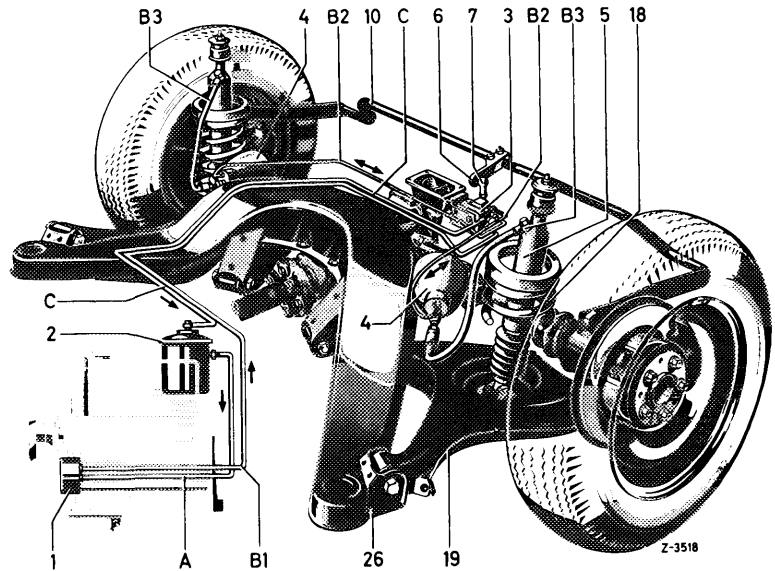

**Layout T-sedans**

- |                        |                      |  |
|------------------------|----------------------|--|
| 1 Pressure oil pump    | 10 Torsion bar       | A Suction line oil supply tank – pressure oil pump     |
| 2 Oil supply tank      | 18 Rear spring       | B1 Pressure line pressure oil pump – level controller  |
| 3 Level controller     | 19 Semi-trailing arm | B2 Pressure line level controller – pressure reservoir |
| 4 Pressure reservoir   | 26 Rear axle carrier | B3 Pressure line pressure reservoir – spring strut     |
| 5 Spring strut         |                      | C Return line level controller – oil supply tank       |
| 6 Lever on torsion bar |                      |  |
| 7 Connecting rod       |                      |  |

On vehicle with level control on rear axle, spring struts (5) are partially supporting members, that is, they are used for carrying rear end of vehicle in addition to rear springs. The spring struts are installed instead of rear shock absorbers and are connected to a gas-filled pressure reservoir (4) each. In addition to level control they are simultaneously serving as shock absorbers. (For closer details refer to section B. "Suspension elements").

With the engine running, the pressure oil pump (1) sucks hydraulic oil from supply tank (2) via suction line (A), so that the oil will flow to level controller (3) via pressure oil line (B1).

The level controller is connected by means of a linkage to torsion bar (10) on rear axle. When set to positions "neutral" or "return flow" the delivered oil will flow back without pressure into supply tank. This circuit of the hydraulic oil is interrupted when rear end of the vehicle drops below vehicle level, since the control disc of the level controller is now keeping the return flow duct to supply tank closed, which in turn results in moving the level controller to position "filling". (For details refer to section D "Control equipment").

The oil delivered in this manner is now flowing into pressure unit (4) and spring struts (5) via check valve in level controller and pressure oil lines (B2) and (B3) while maintaining the required pressure. The resulting pressure increase will raise rear end of vehicle until the specified vehicle level has been attained. The level controller will simultaneously change to position "neutral" and once again establish the condition of pressureless circuit delivery described further above.

When the vehicle is unloaded or when its rear end is raised beyond level position, the level controller is set to "return flow". In such a case, in addition to the oil delivered by the pressure oil pump, the oil initially required for increasing the pressure and also for raising the lowered rear end of the vehicle will return to supply tank from pressure reservoirs and spring struts.

As a result of the outflowing oil, the vehicle level will drop until the level controller is once again in "neutral" position.

Oil pressure in spring struts should not drop below a given basic pressure, so that the spring struts can fully meet their additional jobs of shock absorbers acting independent of positions of level controller. Making sure of that basic pressure is attained by means of a compression spring which pushes the return flow valve in level controller out of reach of control disc when the available pressure is below a given mark.

As a protection against overloading the system, the level controller is additionally provided with a pressure relief valve, which permits the oil delivered by the pressure oil pump to flow back into the supply tank when the pressure in the pressure element is too high, even in "filling" position of level controller.

A distributor with bleed screw located in line system between level controller and suspension elements or a level controller with integrated bleed screw (2nd version starting March 1977) serves for draining the basic pressure resulting independent of the position of the level controller.

## Note

---

A prerequisite for correct operation of level control as well as for obtaining good riding comfort and optimal riding characteristics is a vehicle level set according to specifications both in condition ready-for-driving and under load.

In condition ready-for-driving the rear end of the vehicle is carried by the rear springs and the basic pressure in the suspension elements only. The basic pressure is maintained by drain valve in level controller independent of position of lever. If rear end of vehicle is too low in condition ready-for-driving, raising of rear end should never be attempted by adjusting connecting rod of level controller, since in such a case the vehicle level would be continuously regulated at too high a level under load. The result would be poor riding characteristics, oil flow and knocking noises during deflection, as well as an essentially too highly placed ball head when operating a trailer. In addition, under high load as well as during acceleration, the max. pressure in suspension elements limited by level controller, would be attained so that during such driving conditions the opening noise of the pressure relief valve would be constantly heard as a whistling and knocking noise. If the level is too low in ready-for-driving condition, corrections should therefore be made on rear springs. A prerequisite for evaluating the ready-for-driving level is, however, that the full pressure in suspension elements is available. Prior to measuring the semi-trailing arm position in ready-for-driving condition, the level controller should therefore be moved for a short moment in upward direction into "filling" position and then downwards in "emptying" position with the connecting rod disconnected and the engine running (for "checking vehicle level" refer to 40-300 and 40-310).

## B. Suspension elements

The spring strut is mounted below on semi-trailing arm and at top on dome of frame floor. The spring strut is connected to the pressure reservoir (4) attached to frame floor by means of the pressure line (B3) on housing.

The pressure line (B2) in turn connects the pressure reservoir to level controller. Raising of lowered rear end of vehicle is attained by increasing the oil quantity in oil chamber (a) of spring strut, which results in increased extension of piston rod. The mechanical design of the spring strut is similar to that of a normal shock absorber.

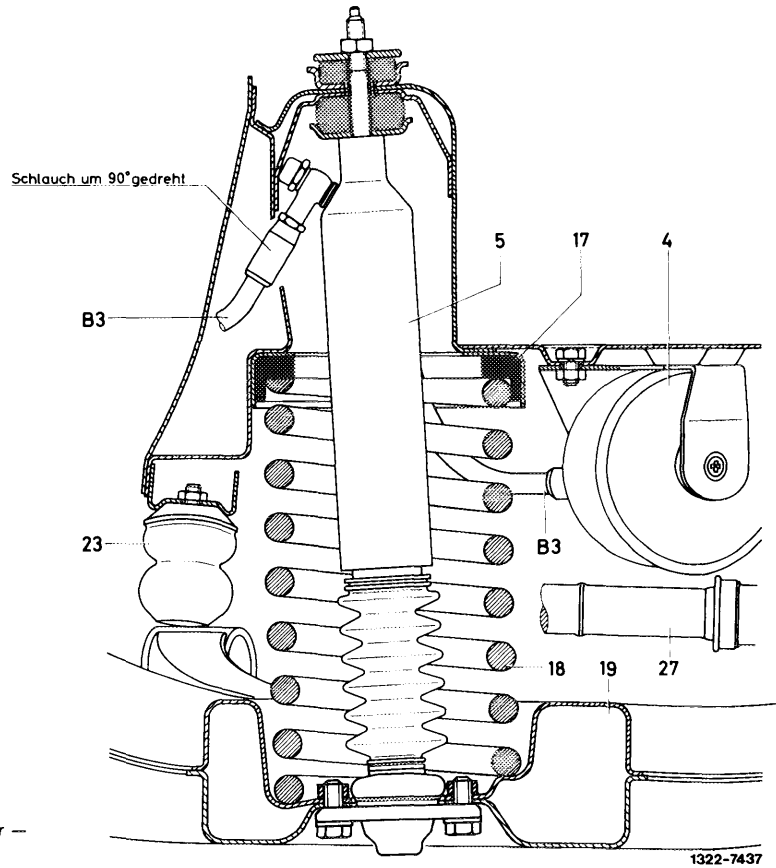

- 4 Pressure reservoir
- 5 Spring strut
- 17 Rubber mount
- 18 Rear spring
- 19 Semi-trailing arm
- 23 Supplementary rubber spring (rebound stop)
- 27 Rear axle shaft
- B3 Pressure line pressure reservoir – spring strut

The pressure reservoir applied is of ball shape. Oil chamber (a) and gas chamber (b) of reservoir are separated by a diaphragm.

The gas chamber is filled with a specified pressure.

As a result of the oil pressure within the system, which is constantly changing in the driven vehicle, for example under the influence of deflections, the diaphragm will adapt itself continuously to the required chamber volume of the oil. The diaphragm will change its shape accordingly inside the ball-shaped housing of the pressure reservoir.

The pressure reservoir can meet these expectations only when the gas-filling pressure remains above a given value.

Layout sedans and coupes

- 3 Level controller
- 5 Spring strut
- 6 Lever on torsion bar
- 7 Connecting rod
- 10 Torsion bar
- 15 Torsion bar connecting rod
- 17 Rubber mount
- 18 Rear spring
- 19 Semi-trailing arm
- 26 Rear axle carrier
- a Oil chamber
- b Gas chamber
- B1 Pressure line pressure oil pump – level controller
- B2 Pressure line level controller – pressure reservoir
- B3 Pressure line pressure reservoir – spring strut
- C Return line level controller – oil supply tank

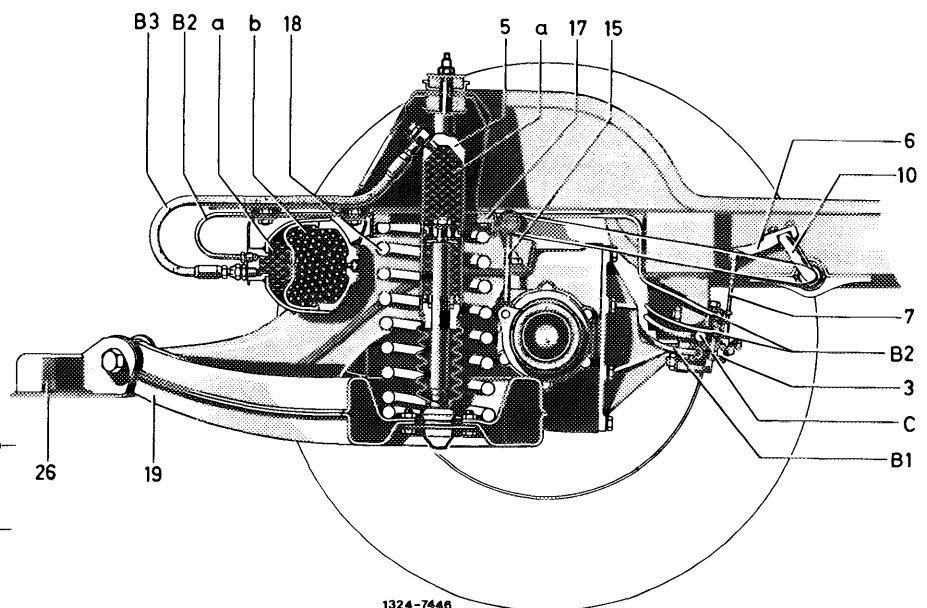

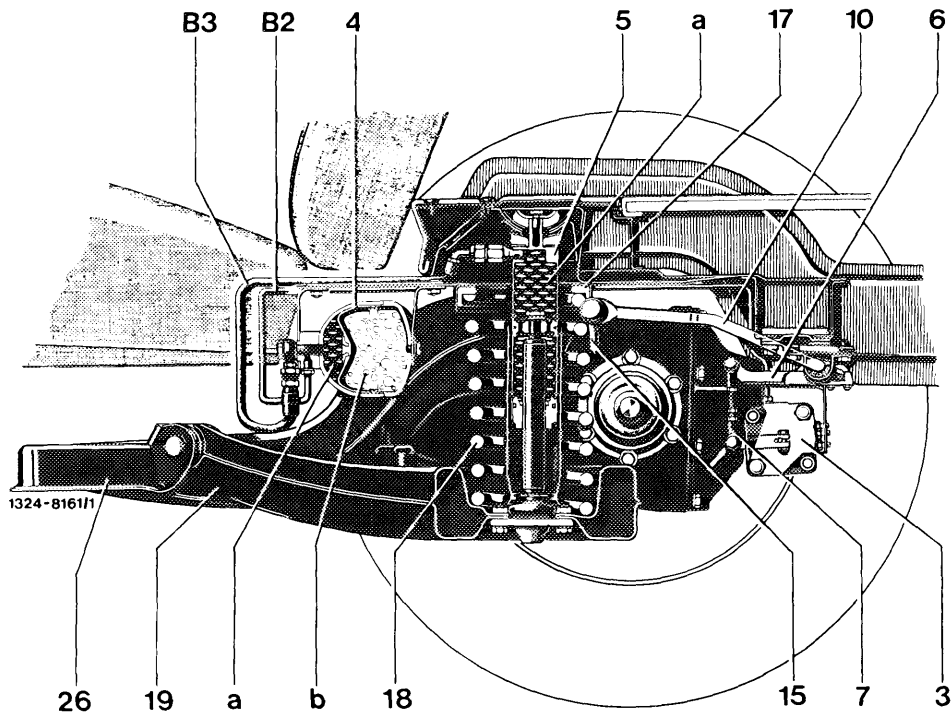

Layout T-sedans

- |                                 |  |
|---------------------------------|--|
| 3 Level controller              | 19 Semi-trailing arm                                   |
| 4 Pressure reservoir            | 26 Rear axle carrier                                   |
| 5 Spring strut                  | a Oil chamber  |
| 6 Lever on torsion bar          | b Gas chamber  |
| 7 Connecting rod                | B2 Pressure line level controller – pressure reservoir |
| 10 Torsion bar                  | B3 Pressure line pressure reservoir – spring strut     |
| 15 Torsion bar – connecting rod |  |
| 17 Rubber mount                 |  |
| 18 Rear spring                  |  |

C. Pressure oil system

**Pressure oil pump**

The pressure oil pump applied is a radial piston pump with four pistons arranged radially in relation to pump shaft.

The pressure oil pump is designed to raise the lowered rear end of vehicle relatively quickly after loading and to make sure that during the following pressureless circuit delivery (circulation), power requirements will be very low.

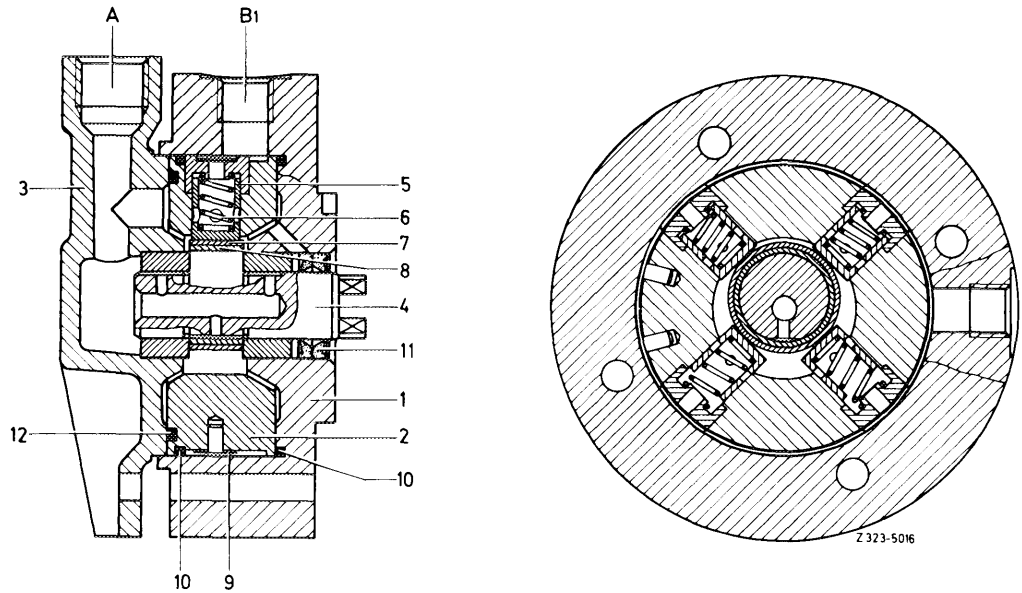

Pressure oil pump MB

- |                      |  |
|----------------------|--|
| 1 Housing            | 9 Reaction sealing strip                                 |
| 2 Center piece       | 10 O-ring  |
| 3 Bearing cover      | 11 Radial sealing rings                                  |
| 4 Eccentric shaft    | 12 O-ring  |
| 5 Piston             | A Suction line oil supply tank –<br>pressure oil pump    |
| 6 Compression spring | B1 Pressure line pressure oil pump –<br>level controller |
| 7 Outer race         |  |
| 8 Inner race         |  |

Section A—B

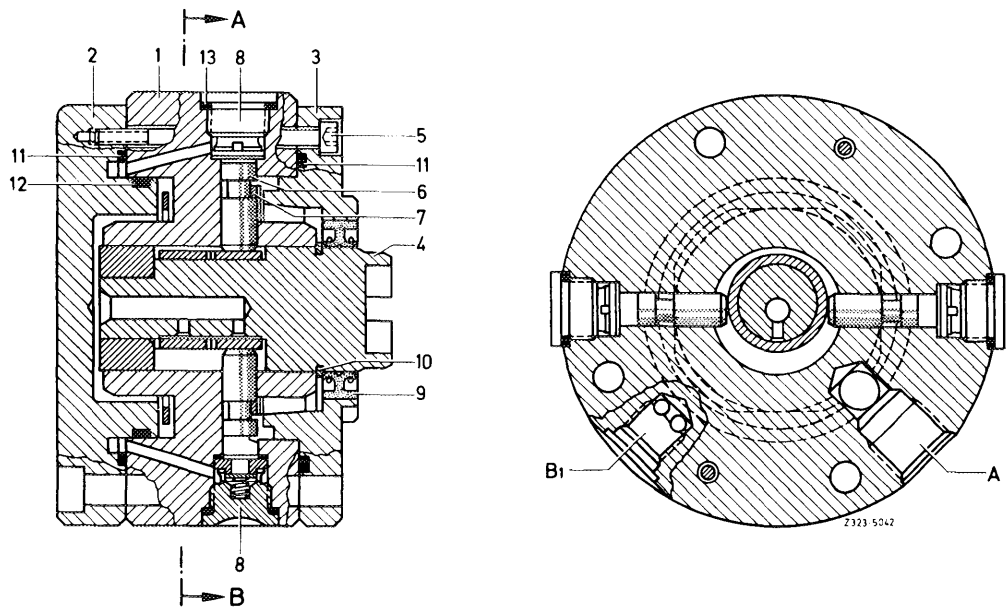

Pressure oil pump Teves

- |                      |  |
|----------------------|--|
| 1 Housing            | 9 Radial sealing ring                                    |
| 2 Cover, front       | 10 Thrust ring   |
| 3 Cover, rear        | 11 O-ring  |
| 4 Cam                | 12 Round-cord ring                                       |
| 5 Hex. socket screws | 13 Sealing ring  |
| 6 Piston             | A Suction line oil supply tank –<br>pressure oil pump    |
| 7 Coupling ring      | B1 Pressure line pressure oil pump –<br>level controller |
| 8 Pressure valve     |  |

## Engine 102

The pressure oil pump (1) is driven directly by camshaft and attached to cylinder head by means of a flange (49).

- 1 Pressure oil pump
- 49 Flange
- A Suction line oil supply tank – pressure oil pump
- B1 Pressure line pressure oil pump – level controller

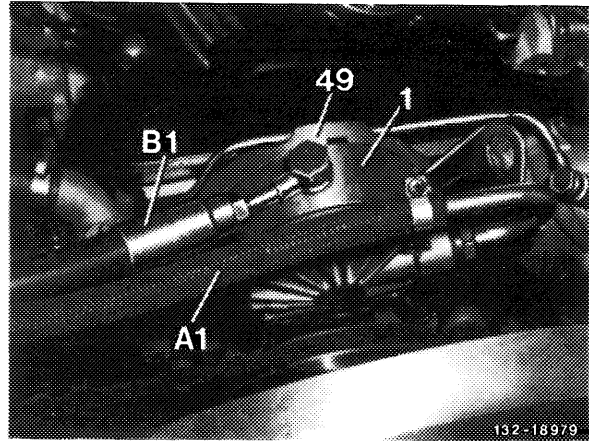

The pump is driven by camshaft (44) by means of driving sleeve (1g) and driver (1b).

- 1 Pressure oil pump
- 1a Camshaft
- 1b Driver
- 1d Gasket
- 1f Hex. socket screw
- 1g Driving sleeve
- 43 Camshaft gear
- 44 Camshaft
- 46 Hex. socket screw
- 49 Flange
- 49a O-ring

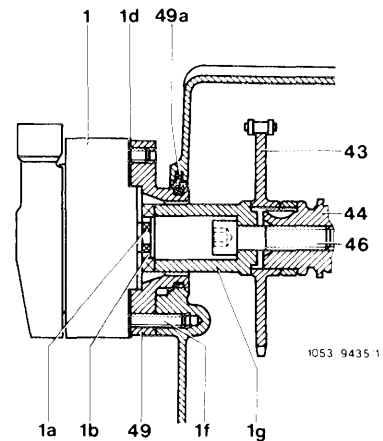

## Engine 110

Pressure oil pump is flanged to front of camshaft housing.

- 1 Pressure oil pump
- A Suction line oil supply tank – pressure oil pump
- B1 Pressure line pressure oil pump – level controller

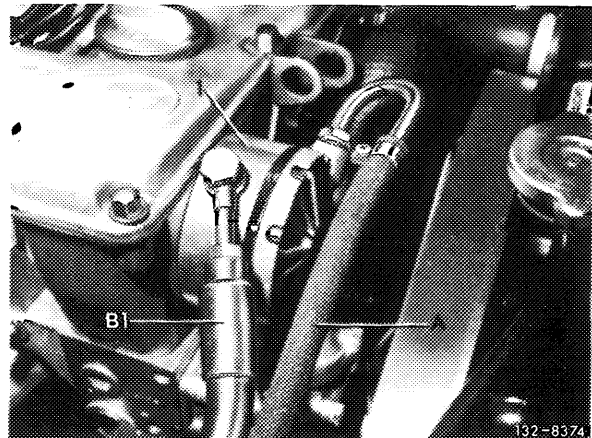

Drive is by means of exhaust-camshaft (44) via spacing sleeve (1g) and driver (1b).

- 1 Pressure oil pump
- 1a Camshaft
- 1b Driver
- 1d Gasket
- 1f Hex. socket screw
- 1g Spacer sleeve
- 43 Camshaft gear
- 44 Camshaft
- 45 Camshaft housing
- 46 Hex. socket screw
- 47 Disc washer

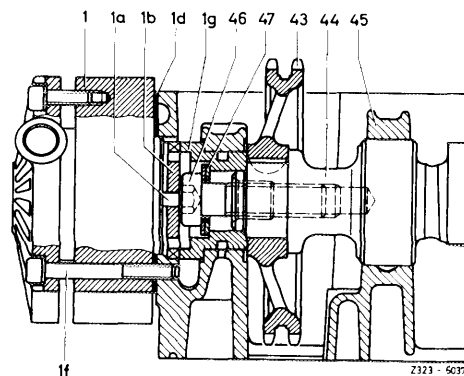



**Engines 114, 115, 123, 130, 180**

Pressure oil pump is flanged to cylinder crankcase.

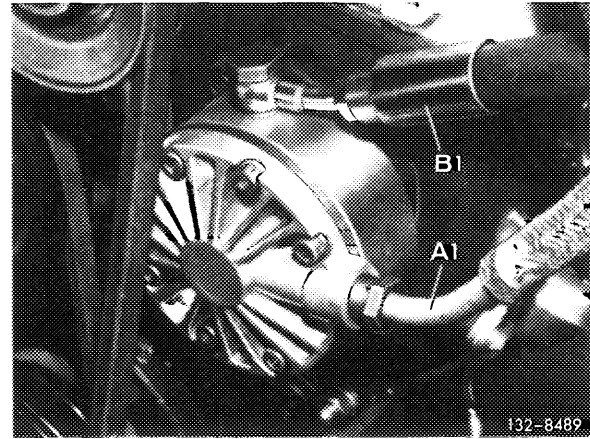

Pressure oil pump MB

- A1 Suction line oil supply tank – pressure oil pump
- B1 Pressure line pressure oil pump – level controller

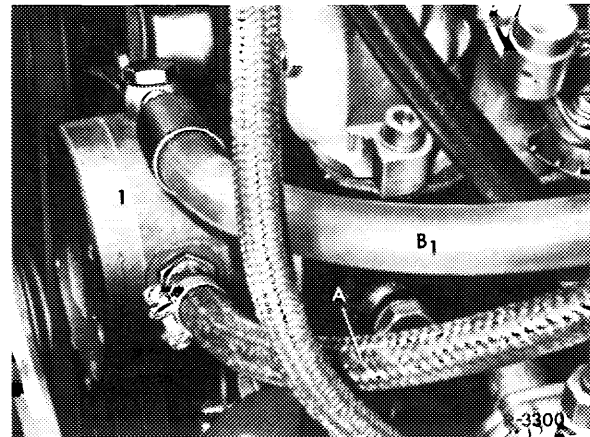

Pressure oil pump Teves

- 1 Pressure oil pump
- A Suction line oil supply tank – pressure oil pump
- B1 Pressure line pressure oil pump – level controller

Drive is effected via intermediate gear (30) and driver (1b).

Pressure oil pump MB

- 1a Cam
- 1b Driver
- 1c Intermediate flange
- 1d Gasket
- 1e Hex. socket screw with special head
- 29 Cyl. crankcase
- 30 Intermediate gear
- 31 Intermediate gear shaft
- 32 Washer
- 33 Front bearing bushing
- 34 Rear bearing bushing

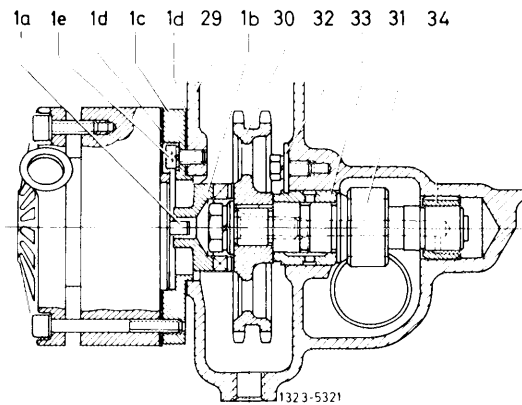

Pressure oil pump Teves

- 1a Cam
- 1b Driver
- 1c Intermediate flange
- 1d Gasket
- 1e Hex. socket screw with special head
- 1f Hex. socket screw
- 29 Cyl. crankcase
- 30 Intermediate gear
- 31 Intermediate gear shaft
- 32 Washer
- 33 Front bearing bushing
- 34 Rear bearing bushing

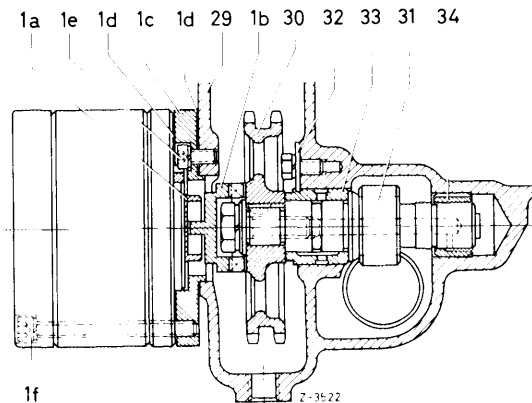

**Engines 116, 117**

Pressure oil pump is flanged to timing housing cover.

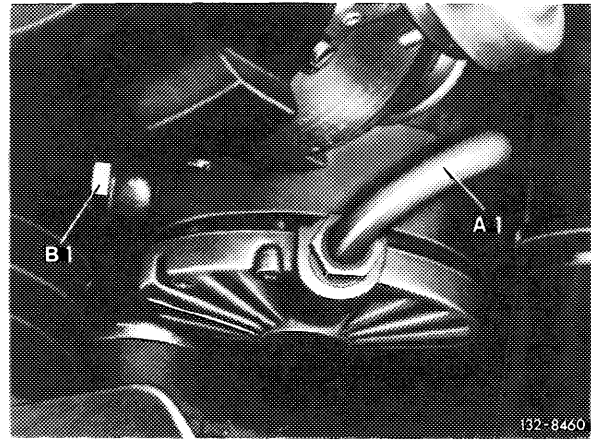

- A1 Suction line oil supply tank – pressure oil pump
- B1 Pressure line pressure oil pump – level controller

Drive is effected via intermediate gear, intermediate gear shaft and driver.

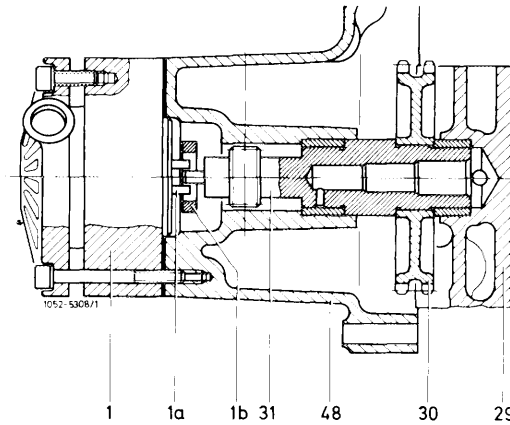

- 1 Pressure oil pump
- 1a Camshaft
- 1b Driver
- 29 Cyl. crankcase
- 30 Intermediate gear
- 31 Intermediate gear shaft
- 48 Timing housing cover

**Engines 615, 616, 617**

Pressure oil pump is flanged to cylinder head.

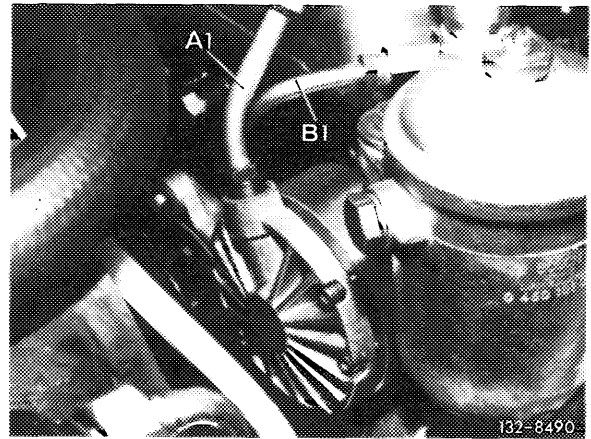

Layout on model 115.1  
Pressure oil pump MB

- A1 Suction line oil supply tank – pressure oil pump
- B1 Pressure line pressure oil pump – level controller

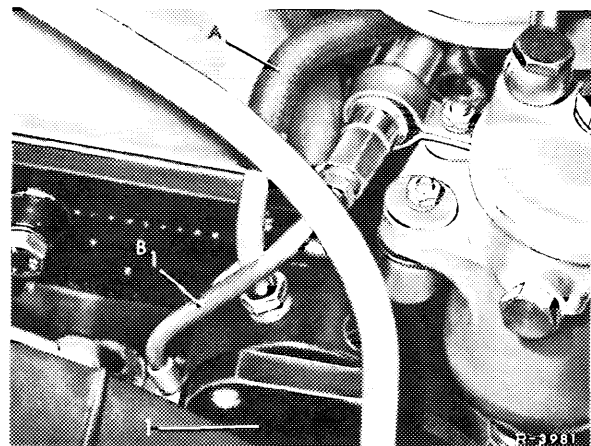

Pressure oil pump Teves

- 1 Pressure oil pump
- A Suction line oil supply tank – pressure oil pump
- B1 Pressure line pressure oil pump – level controller

Layout on model 123.1  
1st version up to May 1979

- 1 Pressure oil pump
- A Suction line oil supply tank – pressure oil pump
- B1 Pressure line pressure oil pump – level controller

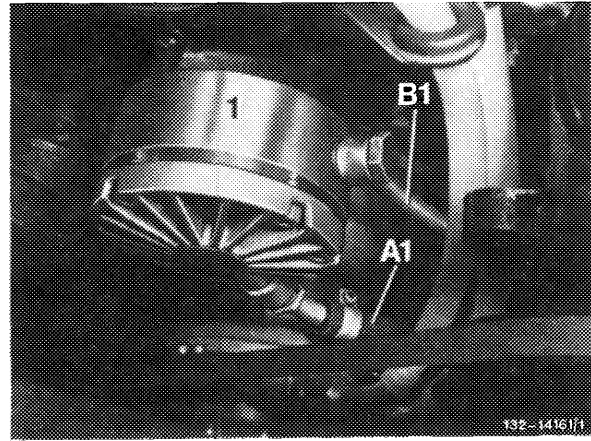

Layout on model 123.1  
2nd version starting June 1979

- 1 Pressure oil pump
- A Suction line oil supply tank – pressure oil pump
- B1 Pressure line pressure oil pump – level controller

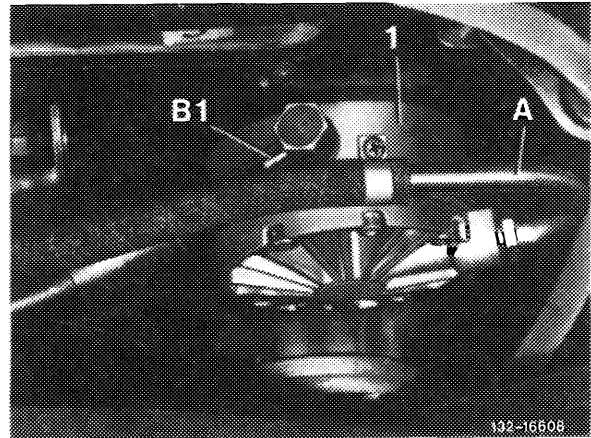

Driven by guide wheel (36) in cylinder head on shaft (37) and driver (1b).

Pressure oil pump MB

- 1a Cam
- 1b Driver
- 1d Gasket
- 1f Hex. socket screw
- 35 Cyl. head
- 36 Guide wheel
- 37 Shaft
- 38 Locking ring
- 39 Snap ring
- 40 Hex. socket screw with special head
- 41 Front bearing bushing
- 42 Rear bearing bushing

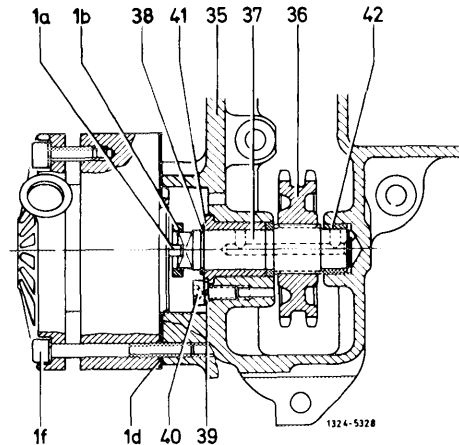

Pressure oil pump Teves

- 1a Cam
- 1b Driver
- 1d Gasket
- 1f Hex. socket screw
- 35 Cyl. head
- 36 Guide wheel
- 37 Shaft
- 38 Locking ring
- 39 Snap ring
- 40 Hex. socket screw with special head
- 41 Front bearing bushing
- 42 Rear bearing bushing

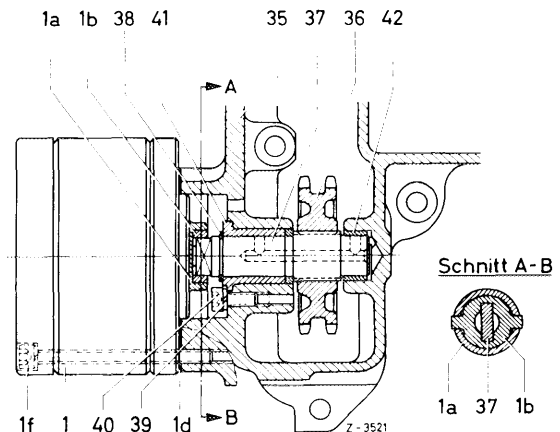

## Oil supply tank

The oil supply tank of model 107, 114, 115, 116 is attached to bracket (9) on the righthand side of the engine compartment by means of a strap.

The oil supply tank is connected to pressure oil pump by means of suction line (A) and to level controller by means of return flow line (C).

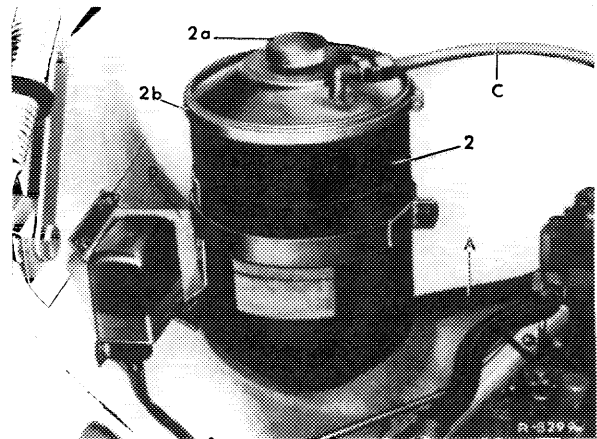

Oil supply tank metal version  
Models 107, 114, 115, 116

- 2 Oil supply tank
- 2a Closing cover with oil dipstick
- 2b Clamping strap
- A Suction line oil supply tank – pressure oil pump
- C Return line level controller – oil supply tank

Cover (2c) of oil supply tank (metal version) is designed as a filter element and also houses the by-pass valve (2f) which serves as a protection against over-pressure in the event of a clogged filter element. The breather cap (2g) serves to prevent any foaming of the oil.

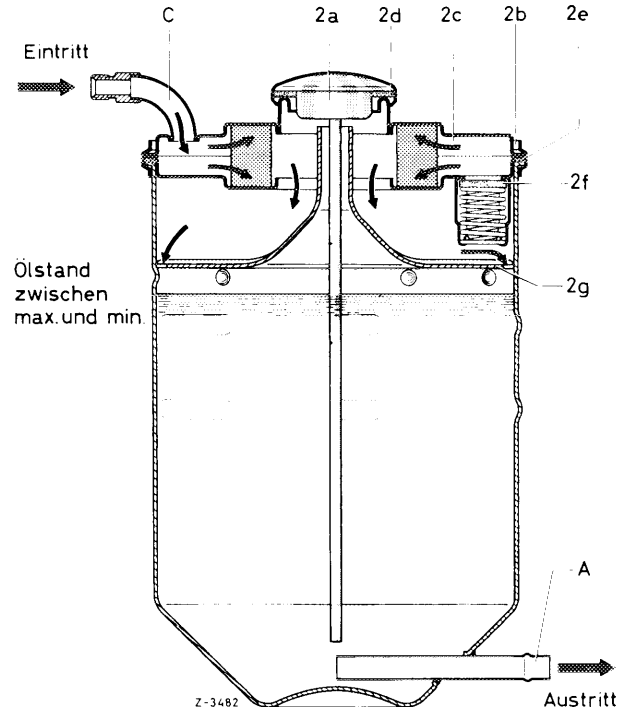

Oil supply tank metal version  
Models 107, 114, 115, 116  
(oil level shown between max. and min.)

- 2 Oil supply tank
- 2a Closing cap with oil dipstick
- 2b Clamping strap
- 2c Cover with filter element
- 2d Rubber sealing ring
- 2e Rubber sealing ring
- 2f By-pass valve
- 2g Breather cap
- A Suction line oil supply tank – pressure oil pump
- C Return flow line level controller – oil supply tank

Model 116 has been supplied with a plastic oil supply tank since the end of 1975. Concurrently, the oil supply tank has been shifted to the left front side of the engine compartment.

On model 123, the oil supply tank is made of plastic material and is located on the righthand side of the engine compartment.

Oil supply tank  
Model 123 Standard

- 2 Oil supply tank
- 2a Closing cover with oil dipstick
- A1 Suction line oil supply tank – pressure oil pump
- B1 Pressure line pressure oil pump – level controller
- C Return flow line level controller – oil supply tank

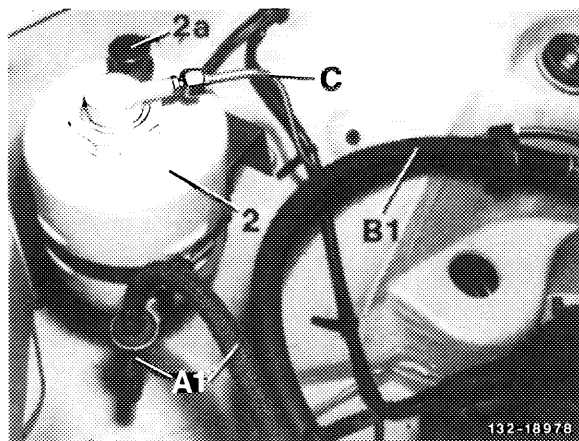

Oil supply tank  
Model 123.193 <sup>(USA)</sup>  
up to model year 1985

- 2 Oil supply tank
- 2a Closing cover with oil dipstick
- 9 Holder for oil supply tank
- 9b Holder for high pressure expansion hose
- B1 Pressure line pressure oil pump – level controller
- C Return flow line level controller – oil supply tank

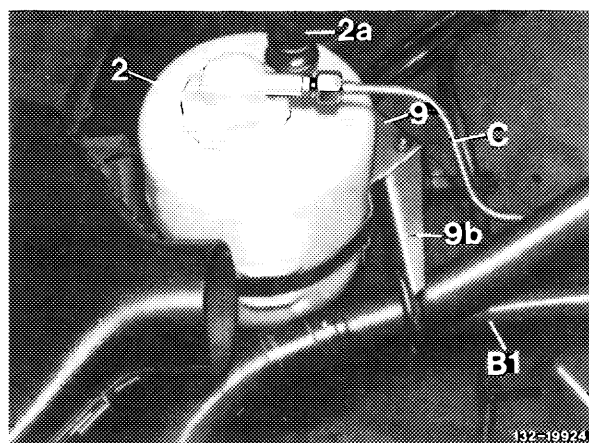

On model 123.193 <sup>(USA)</sup> starting model year 1985, the oil supply tank has been shifted from the righthand side of the engine compartment to the left.

Oil supply tank  
Model 123.193 <sup>(USA)</sup>  
starting model year 1985

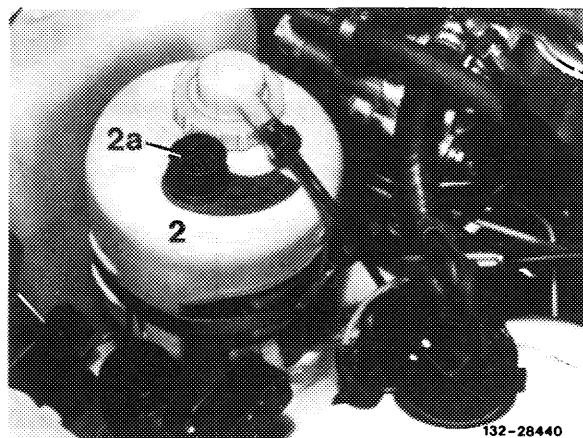

On model 126, the oil supply tank is arranged on the lefthand side of the engine compartment.

Oil supply tank model 126

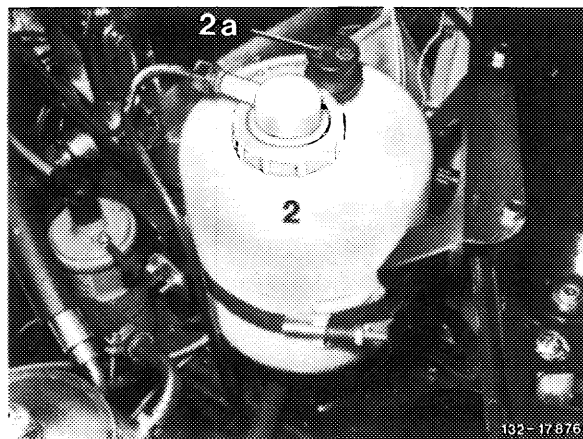

The filter element (2h) in oil supply tank (plastic version) is replaceable.

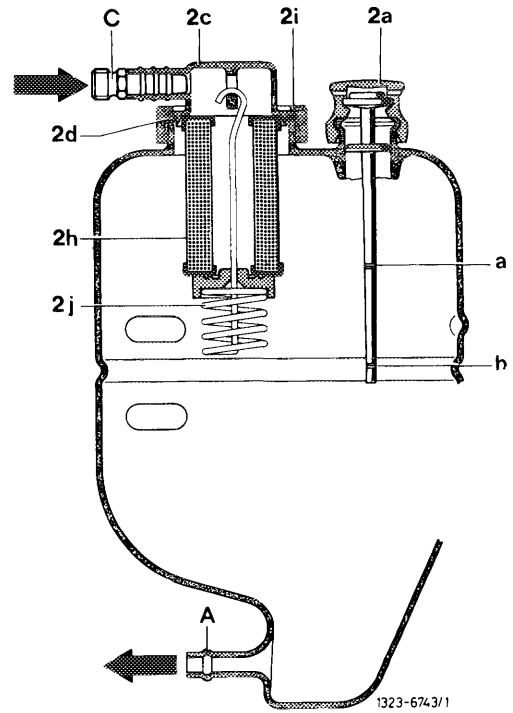

**Oil supply tank plastic version**

- 2 Oil supply tank
- 2a Closing cap with oil dipstick
- 2c Cover with connection
- 2d Rubber sealing ring
- 2h Filter element
- 2i Closing nut
- 2j Closing spring
- a Max. - mark
- b Min. - mark
- A Suction oil supply tank – pressure oil pump
- C Return line level controller – oil supply tank

**D. Control equipment**

The level controller (3) is attached to frame floor by means of bracket (8) and connected to lever (6) on torsion bar (10) by means of connecting rod (7).

The bleed screw in distributor or level controller (11a) serves for draining the pressure in system for the purpose of repair and inspection jobs.

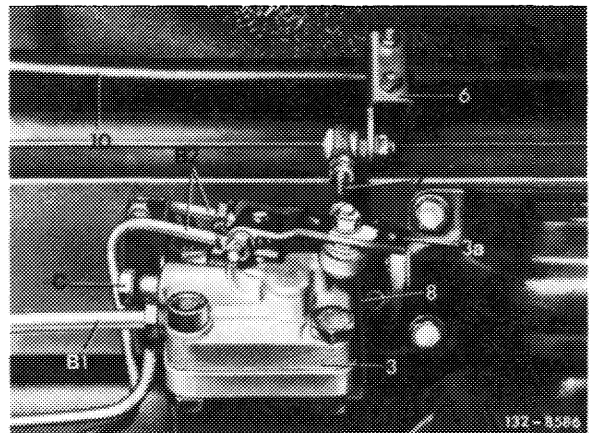

Level controller without bleed screw 1st version

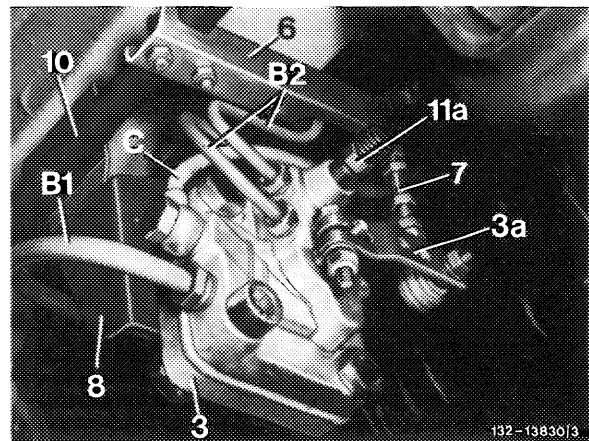

**Level controller with bleed screw 2nd version**

- 3a Lever
- 11a Bleed screw
- B1 Pressure line pressure oil pump – lever controller
- B2 Pressure line level controller – pressure reservoir
- C Return line level controller – oil supply tank

## Functional positions of level controller

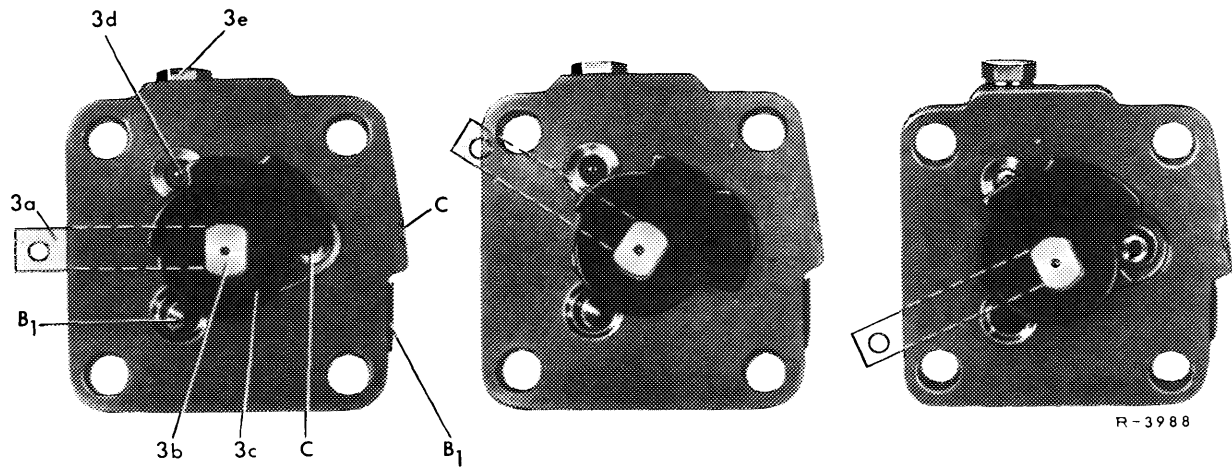

**Neutral**  
Vehicle in level position;  
lever in center position

**Filling**  
Vehicle rear end lowered after  
loading; lever above center  
position

**Return flow**  
Vehicle rear end raised after  
unloading; lever below  
center position

3 Level controller  
3a Lever  
3b Control shaft

3c Control disc  
3d Return valve  
3e Closing plug

B1 Pressure duct from pressure oil pump  
C Return flow duct to oil supply tank

### “Neutral” position

---

Oil entering via feed duct (B1) is returned without pressure to supply tank via return flow duct and return flow line (C). Return flow valve (3d) remains closed.

### “Filling” position

---

Control disc (3c) has closed return flow duct (C). Under influence of pertinent pressure, the oil is guided to the suspension elements via pressureless ball check valve (3f) and duct (B2). Raising of vehicle rear end into level position will once again attain “neutral”. The system is protected against overload by the pressure relief valve (3g) which opens when the max. permissible pressure is attained.

### “Return flow” position

---

Control disc has opened return flow valve (3d). This will lower the pressure prevailing in suspension elements. The oil flows through the opened return flow valve and via the fully opened return flow duct (C) back to supply tank together with the oil delivered by pump. When the level position of the vehicle has once been attained, the control disc will close return flow valve (3d). Provision of the basic pressure required for function of spring struts as shock absorbers is attained independent of position of controller by the outer compression spring of the return flow valve (3d) pushing the return flow valve out of range of control disc when pressure in suspension element drops below a given value, so that the pressure cannot drop any further.

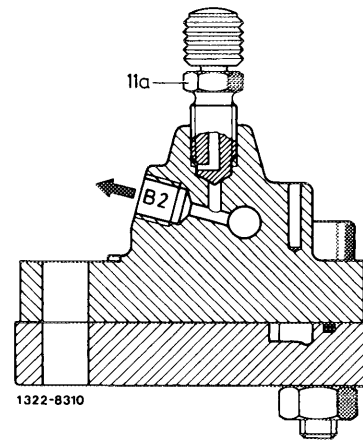
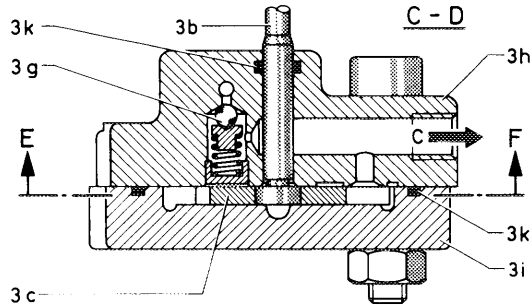
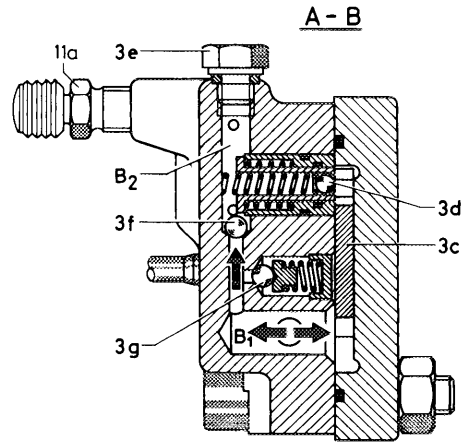
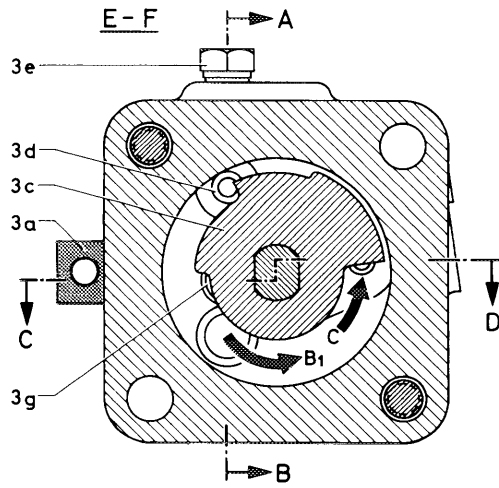

- 3 Level controller
- 3a Lever
- 3b Control shaft
- 3c Control disc
- 3d Return flow valve
- 3e Closing plugs with sealing rings
- 3f Check valve
- 3g Pressure relief valve
- 3h Housing
- 3i Cover
- 3k O-ring
- 11a Bleed screw

- B1 Pressure duct from pump
- B2 Pressure duct to suspension elements
- C Return flow valve to supply tank