

32–510 Checking spring struts

Test values of spring struts

Part no.	Color code on joint of lower suspension	Test values in N at 100/min and 50 mm stroke	
		Values for new spring struts Pull	Push
1st version with rubber mount			
107 320 00 13	4 diagonal stripes green	2000	800
114 320 06 13	1 diagonal stripe red	2100	760
114 320 07 13	2 diagonal stripes red	2500	980
116 320 29 13	2 diagonal stripes green	3100	1150
116 320 30 13	1 diagonal stripe green	2200	860
2nd version with ball joint ¹⁾			
114 320 12 13	1 stripe red	2050	710
114 320 14 13	2 stripes red	2650	970
116 320 31 13	1 stripe green	2250	790
116 320 32 13	2 stripes green	3250	1150
116 320 45 13 ^{2) 3)}	3 stripes green	2400	820
116 320 46 13 ²⁾	4 stripes green	3050	1180
123 320 04 13	1 stripe white	1750	700
123 320 05 13	2 stripes white	2700	1030
123 320 07 13 ²⁾	3 stripes white	2350	970
123 320 08 13 ²⁾	4 stripes white	2700	1030
123 320 10 13 ²⁾	1 stripe white	1650	740
123 320 11 13 ²⁾	4 stripes white	2700	1030

¹⁾ Installed starting May 1974.

²⁾ Version with 24 mm piston rod dia. starting July 1979.

³⁾ At start of series model 126 approx. 100 vehicles were provided with spring struts part no. 126 320 06 13. The damping force adjustment of spring struts corresponds to version part no. 116 320 45 13.

Permissible oil consumption

for 10 000 km	max. 0.4 l
---------------	------------

Sight test

Carefully check piston rod for surface damage.

Check piston rod for distortion. A distorted piston rod will be noticed during stroke by binding in guide bushing.

Note: For lubrication of guide bushing located outside piston rod seal, design provides an oil film on piston rod.

The oil film and thereby the oil outlet provided is somewhat thicker than for shock absorbers. Oil deposits inside dust guard are therefore normal.

A major leak is indicated when with the vehicle stopped a number of drops will appear underneath spring strut and oil consumption of level control system is above permissible value.

Alignment of suspension points is important for correct function of piston rod seal. Be sure to check piston rod seal in the event of leaks to see whether alignment of suspension points is in order (32–126).

Note: On spring struts of T-sedans, check bores on disc (5s) for contamination.

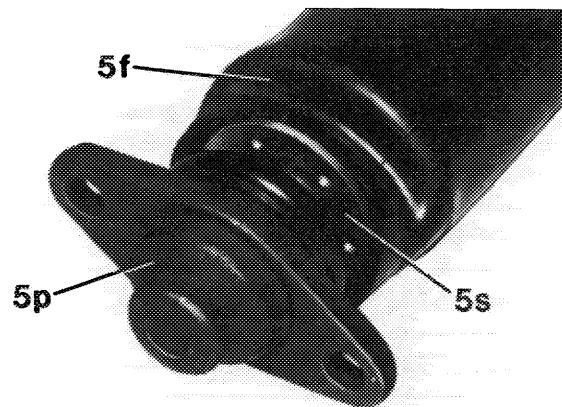

132-16604

If a disc of the 1st version (A) is installed, exchange disc for 2nd version (B) with larger bores (8 mm dia.) (32–612).

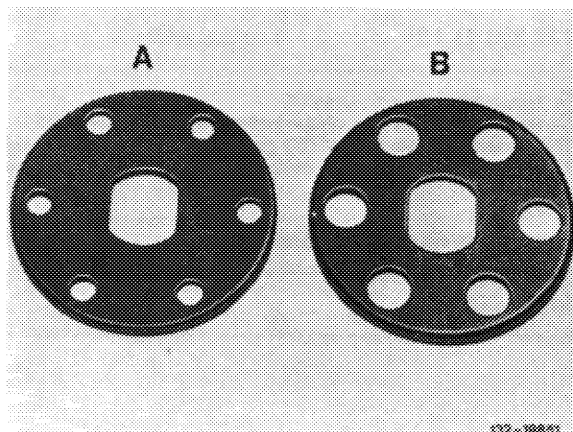

132-16601

Rattling noises

Check upper suspension for correct assembly, lower suspension for tight seat of fastening clip and rubber mount in housing eye or ball joint for absence of play.

Check alignment of upper suspension point on frame floor in relation to lower suspension point on semi-trailing arm (refer to "check alignment of rear shock absorbers" — steel suspension 32–126).

Attention!

If the alignment of the suspension parts has not been in order, replace spring struts only if they have already been running for an extended period at a heavily deviating alignment or if they have been clearly leaking.