

33-520 Reconditioning bearing of lower control arm

A. 2-part bearing

Lubricants

Slide fluid Naphtolen for installing rubber bearings in lower control arm optionally also slide fluid Paladinol	000 989 04 60 000 989 08 60
---	--------------------------------

Special tool

Installer for bearing of lower control arm

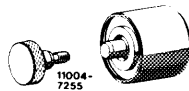

123 589 01 35 00

Note

During repairs, suitably install 3-part bearing (refer to section "B").

Removal

- 1 Clamp control arm into vise provided with light alloy jaws.
- 2 Cut off bead of clamping sleeve with a counter-sink.
- 3 Push out clamping sleeve, drill off up to half, if stuck.
- 4 Loosen rubber bearing by moving bearing back and forth in control arm and remove.

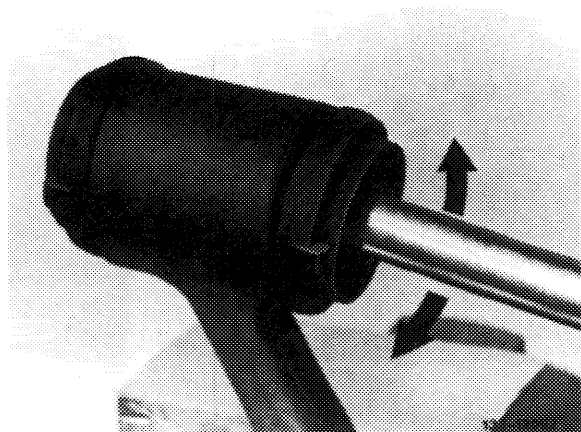
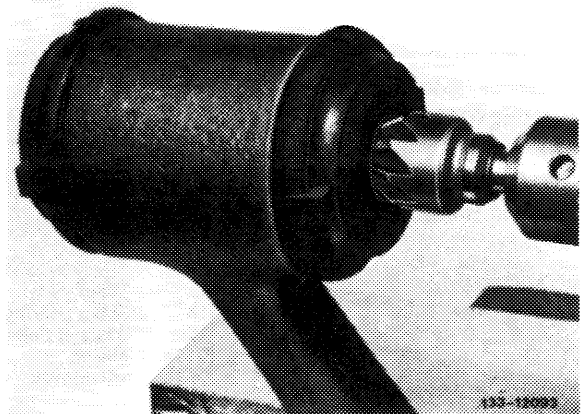

Installation

5 Thoroughly clean mounting bore for bearing in lower control arm, use fine abrasive cloth, if required.

6 Coat rubber bearing along circumference and mounting bore in control arm with slide fluid.

Attention!

Do not use oil or grease.

7 Press rubber bearings individually into control arm in vise, making sure that the naps of the rubber bearing are vertical in relation to the reference plane of the control arm.

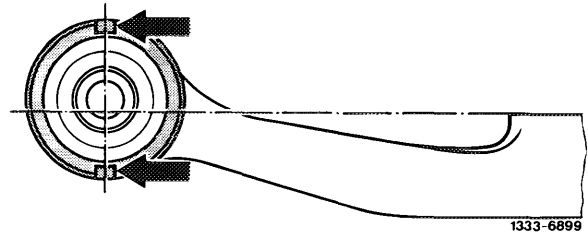

8 Insert clamping sleeve (16a).

9 Position installation tool in such a manner that the unbeaded side of the clamping sleeve faces towards housing (041a) (refer to arrow).

10 Compress rubber bearing (16) in vise up to stop, this will simultaneously bead the clamping sleeve.

16 Rubber bearing
16a Clamping sleeve
041a Housing
041b Thrust piece

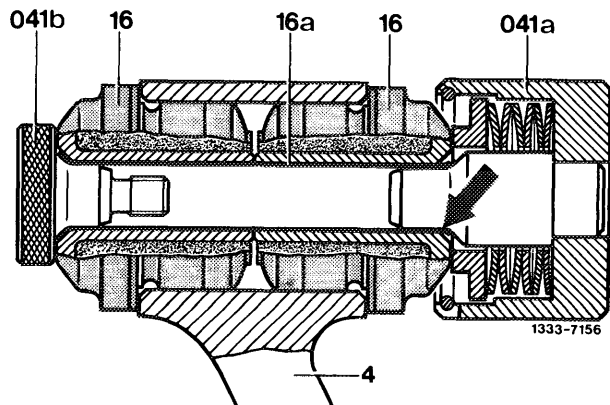

B. 3-part bearing

Lubricants

Slide fluid Naphtolen for installation of radial torsion rubber bearing	000 989 04 60
optionally also slide fluid Paladinol	000 989 08 60

Special tools

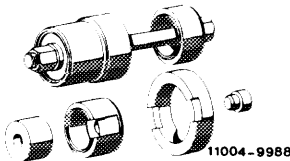
Remover and installer for bearing in lower control arm		126 589 01 43 00
--	--	------------------

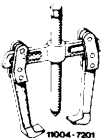
Two-arm puller		000 589 88 33 00
----------------	---	------------------

Conventional tool

Countersink dia. 25/90°

Note

Starting January 1982, vehicles with 15" tires as well as police vehicles are provided with the 3-part bearing in lower control arm (similar to model 126). In the event of repairs, this bearing can also be installed in other vehicles of model 123 (e.g. with high front axle load).

- 2 Frame cross member
- 4 Lower control arm
- 16 Axial-torsion rubber bearing
- 17 Radial-torsion rubber bearing
- 19 Eccentric bolt (camber adjustment)
- 19a Eccentric disc

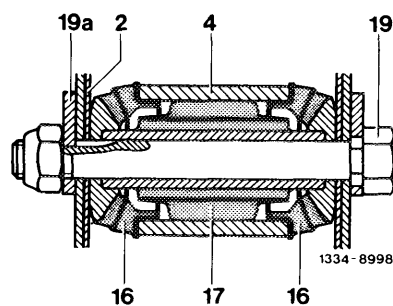

Conversion to 3-part bearing must be made on both vehicle sides. Bearing comprises the radial-torsion rubber bearing (17) and the two axial-torsion rubber bearings (16).

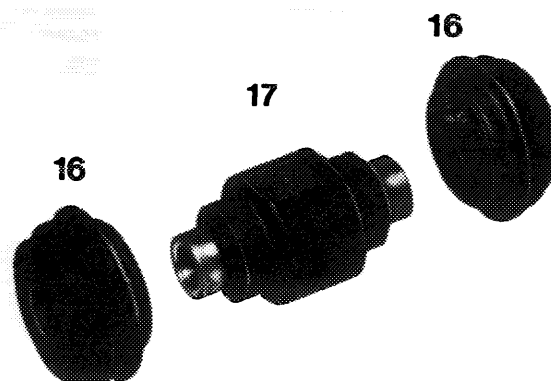

The required remover and installer for reconditioning bearing of lower control arm comprises 8 parts.

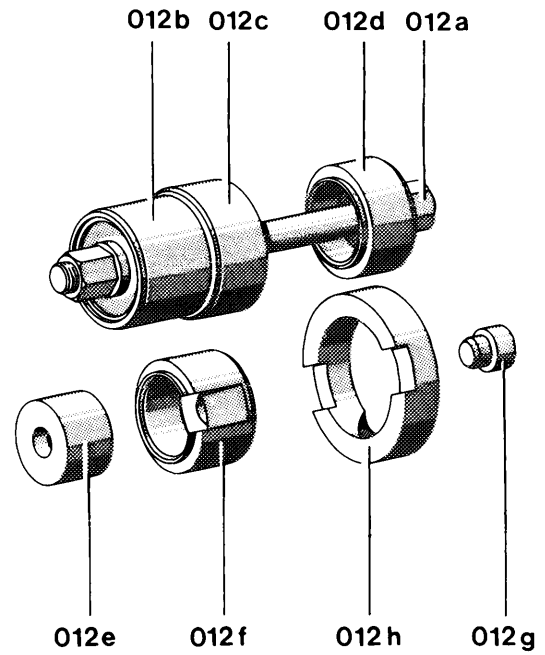

- 012a Tensioning screw
- 012b Thrust bearing
- 012c Thrust piece
- 012d Counterholder
- 012e Thrust piece
- 012f Counterholder
- 012g Mushroom thrust head
- 012h Holding ring

1334 - 10 767

Removal

- 1 Clamp control arm into vise using light alloy jaws.
- 2 Enlarge one side of rubber bearing with countersink until edge of radial-torsion rubber bearing shows up.



- 3 Plug thrust piece (012g) and holding ring (012h) on control arm (4). Place puller (019) on tool and screw-in bolt until axial- and radial-torsion rubber bearing is pushed out of control arm.

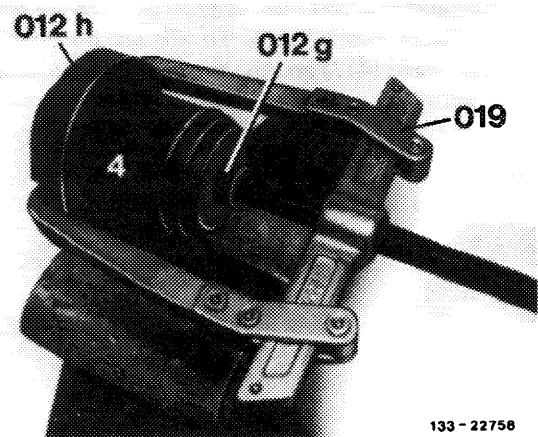

4 Knock second, remaining axial-torsion rubber bearing (16) out of control arm (4) by means of a punch.

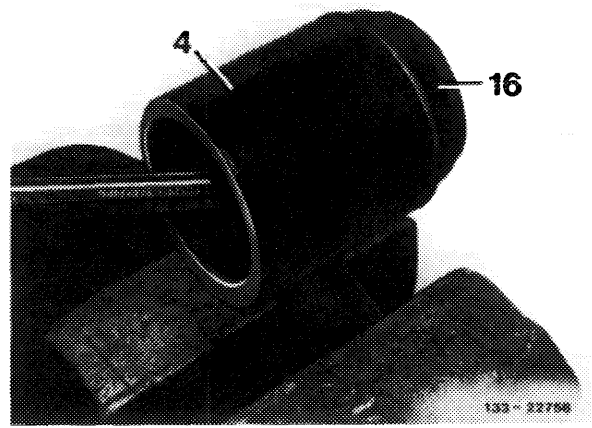

Installation

5 Thoroughly clean mounting bore for bearing in lower control arm, use fine emery cloth, if required.

6 Coat radial-torsion rubber bearing on circumference and mounting bore in control arm with slide fluid.

Attention!

Do not use oil or grease.

7 Insert radial-torsion bearing (17) into control arm.

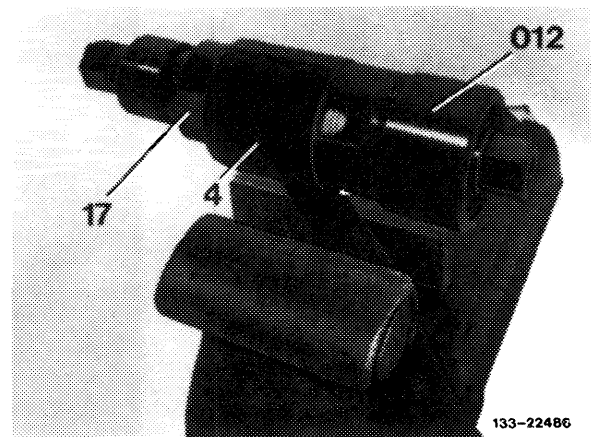

Note: Make sure that the two flats of the rubber bearing are in line with reference flat of control arm.

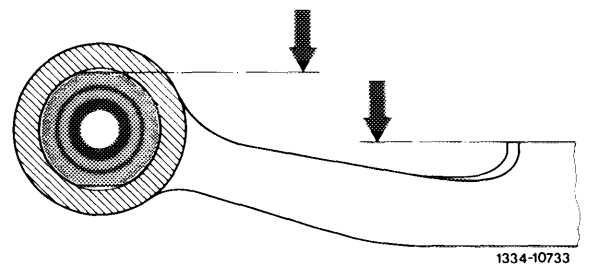

8 Insert radial-torsion bearing (17) until rubber edge is flush with edge of control arm with radial-torsion bearing relaxed.

Note: The rubber edge is seen through window in counterholder (012f).

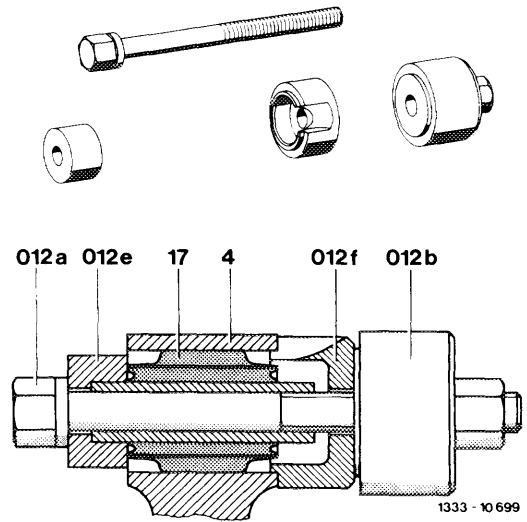

9 Pull one axial-torsion bearing (16) on internal bushing of radial-torsion bearing (17) while simultaneously inserting bearing into control arm.

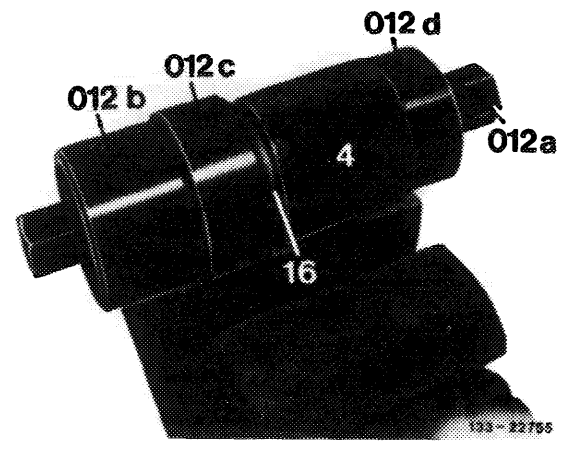
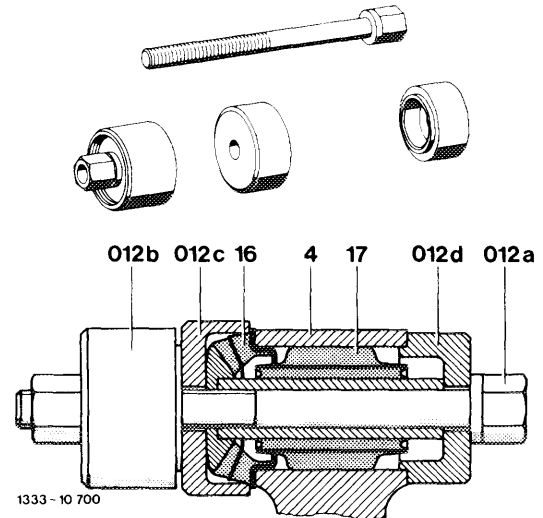

10 Mount second axial-torsion bearing.

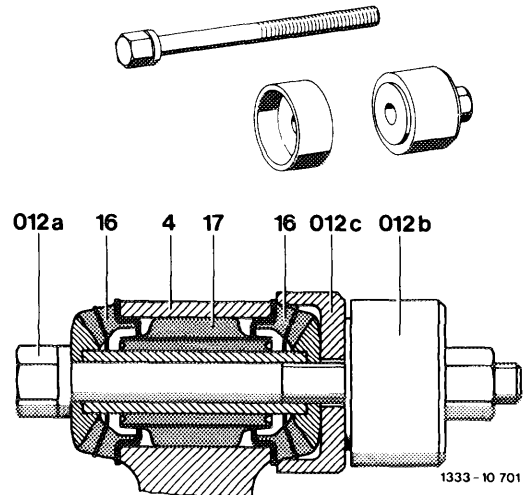

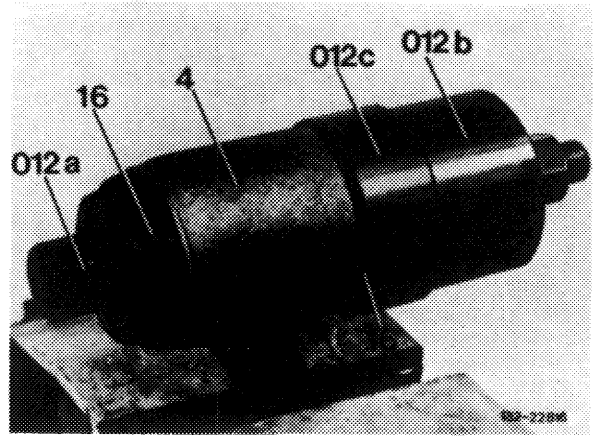

11 Check seat of mounted axial-torsion bearing (16). Both bearings should rest against control arm (4).

