

35–310 Removal and installation of coupled semi-trailing arm, replacement of rubber bearing

Diagonal swing axle with starting torque compensation

Slide fluid for pressing-in rubber bearing

Slide fluid (Naphtolene H or slide paste made by Fahr) 000 989 08 60

Tightening torques

Nm

Hex nut for attaching coupled semi-trailing arm to rear axle carrier

120

Hex bolt for attaching rear axle shaft to rear axle shaft flange

1st version (M 12)

95

2nd and 3rd version (M8)

30

Special tools

Remover and puller for rubber bearing

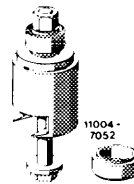

116 589 13 43 00

Assembly tool for rear axle shaft

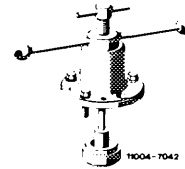

116 589 24 61 00

Removal

- 1 Remove complete rear axle together with rear axle carrier (35–010).
- 2 Lower coupled semi-trailing arm down to deflection stop.
- 3 Loosen hex. screw (M12) of 1st version or hex. screw (M8) with spacing sleeve and tensioning washer of 2nd and 3rd version for attaching rear axle shaft to rear axle shaft flange and remove.

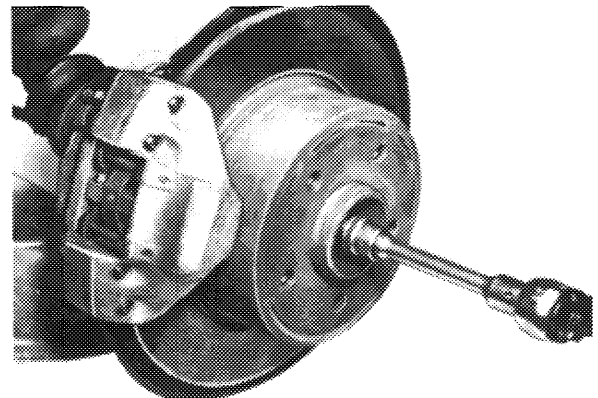

135 – 8499

4 If required, force rear axle shaft out of rear axle shaft flange by means of assembly tool.

5 Loosen hex nuts for attaching coupled semi-trailing arm, pull out hex bolts and remove coupled semi-trailing arm.

Attention!

When removing and transporting coupled semi-trailing arm, do not damage cover plate of brake disc.

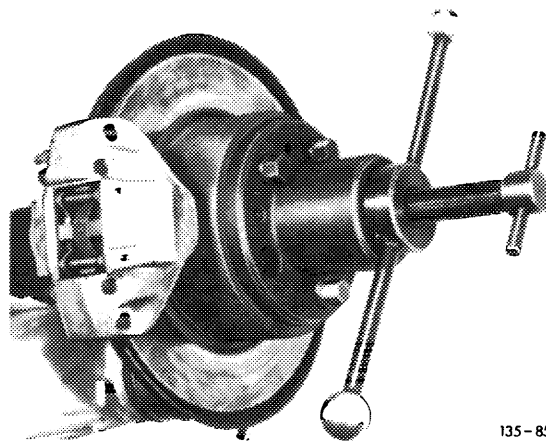

135-8500/1

Replacing rubber bearing

6 Pull rubber bearing out of coupled semi-trailing arm.

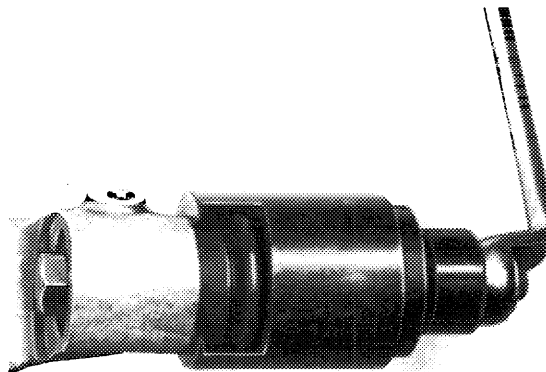

135-8501

7 Coat new rubber bearing with slide fluid and pull in from outside inwards up to stop on eye of coupled semi-trailing arm.

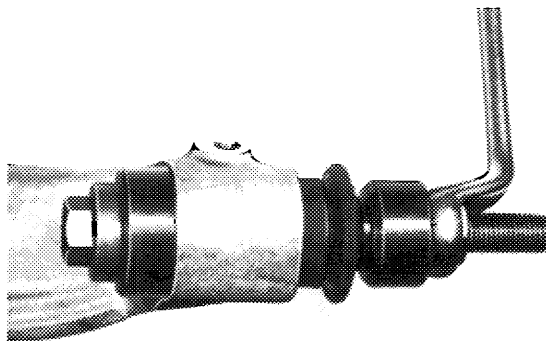

135-8502

Installation

8 Insert coupled semi-trailing arm into rear axle carrier. Insert hex bolts and screw-on nuts with snap rings, but do not yet tighten.

9 Pull rear axle shaft into rear axle shaft flange by means of assembly tool.

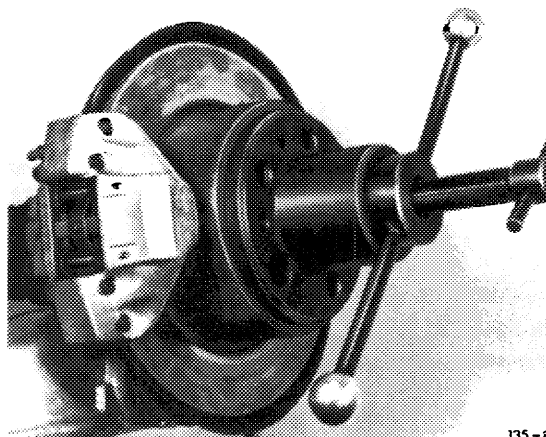

135-8500

10 Remove assembly tool.

11 Tighten hex. screw for fastening rear axle shaft to rear axle shaft flange of 1st version (M 12 item 79) to 95 Nm.

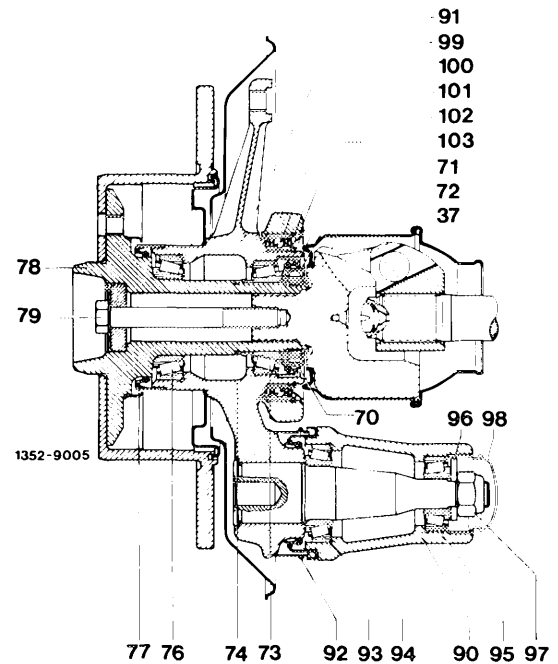

1st version

79 Hex. screw M 12 x 90

12 On 2nd and 3rd version mount hex. screw (M 8x90 or M 8x85 item 79) with tensioning washer (79a) and spacing sleeve (79b 72.5 mm or 67.5 mm long) and tighten to 30 Nm.

Attention!

Replace lock washer (79a) after one-time use. Provide lock washer (79 a) in range of screw head with oil.

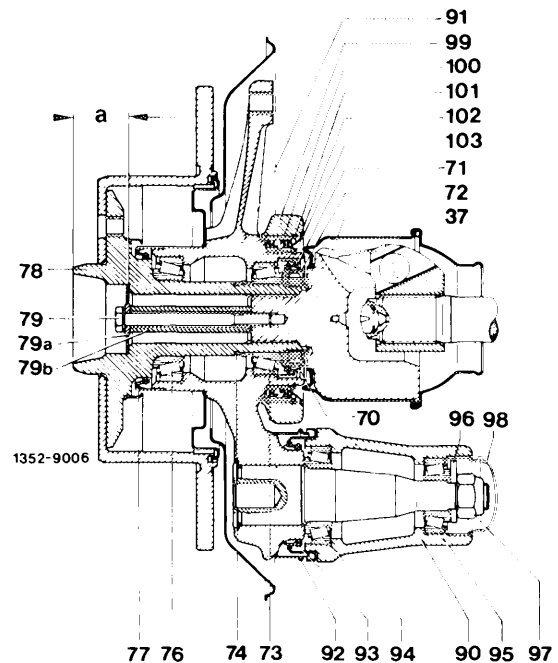

2nd version

79 Hex. screw M 8x90
79a Tensioning washer (lock washer)
79b Spacing sleeve (72.5 mm long)
a = 32 mm

Note: Starting September 1979 the inside contour (arrow) of rear axle shaft flange has been modified and the contact surface of the tensioning washer has been moved inwards by an additional 5 mm. To guarantee the correct association of hex. screw and spacing sleeve, measure distance "a" on rear axle shaft flange from face to contact surface of tensioning washer by means of a depth gauge and take the length for the spacer sleeve and hex. screw from table.

Be sure to avoid wrong combinations!

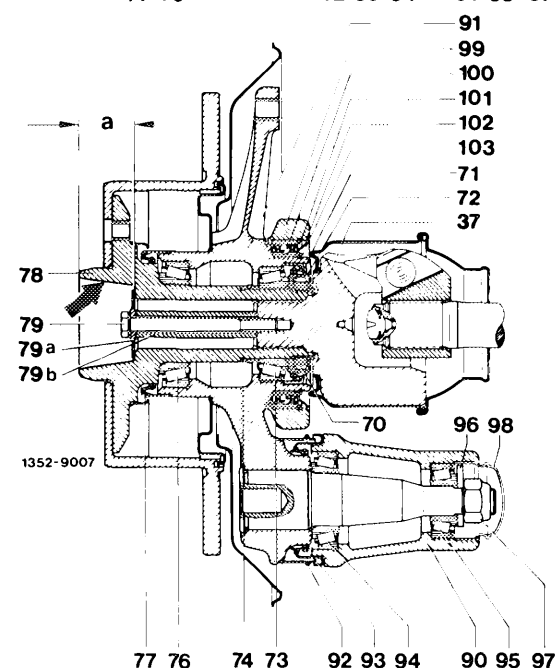

3rd version

79 Hex. screw M 8x85
79a Tensioning washer
79b Spacing sleeve (67.5 mm long)
a = 37 mm

2nd rear axle shaft flange version

a = 32 mm

Pertinent hex. screw = M 8x90

Pertinent spacing sleeve = 72.5 mm

3rd rear axle shaft version

a = 37 mm

Pertinent hex. screw = M 8x85

Pertinent spacing sleeve = 67.5 mm

As an additional external identification characteristic, the shorter hex. screw is provided with a recess on hex. head, on the shorter spacing sleeve the surface is bright, on the former sleeve it is phosphatized (bonderized).

13 Lift or lower coupled semi-trailing arm until rear axle shafts are horizontal.

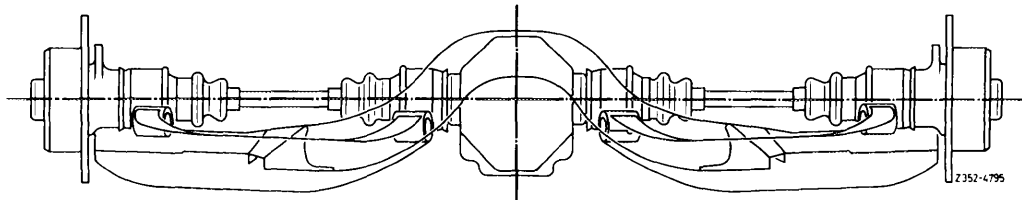

14 Tighten hex nuts for attaching coupled semi-trailing arm to 120 Nm.

15 Install rear axle (35-010).