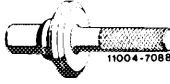
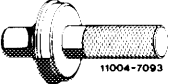
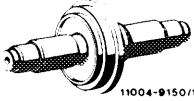
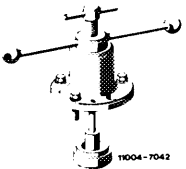

35–540 Replacement of radial sealing ring of rear axle shaft

Rear axle center piece installed.

Tightening torques		Nm
Hex socket necked-down bolt for attaching rear rubber bearing to rear axle end cover (rubber bearing 1st version)		140
Hex socket bolts or hex bolts for attaching rear rubber bearing to rear axle end cover (rubber bearing 2nd version)		120
Hex bolts for attaching rear rubber bearing to frame floor		25
Hex bolts, self-locking, for attaching rear rubber bearing to frame floor		30
Hex bolts for attaching rear axle end cover		45
Hex bolt for attaching rear axle shaft to rear axle shaft flange	1st version M 12	95
	2nd and 3rd version M 8	30
Special tools		
Installer for radial sealing ring with 65 mm OD		116 589 05 43 00
Installer for radial sealing ring with 81 mm OD		116 589 10 15 00
Installer for radial sealing ring for rear axle center piece without lateral bearing cap		126 589 00 15 00
Assembly tool for removal and installation of rear axle shaft on rear axle shaft flange		116 589 24 61 00

Layout of rear axle center piece with lateral bearing caps

- | | | | |
|-----|------------------------|-----|-------------------|
| 3 | Rear axle housing | 26 | Locking ring |
| 16 | Side gear | 27 | Spacing ring |
| 17 | Thrust washer | 28a | Rear axle shaft |
| 18 | Differential pinion | 28c | Inner spider |
| 19 | Ball washer | 28d | Spider joint hub |
| 20 | Differential bolt | 28e | Ball |
| 20a | Clamping sleeve | 28f | Stop buffer |
| 21 | Tapered roller bearing | 28g | Protective sleeve |
| 22 | Sealing ring | 28h | Sealing ring |
| 23 | Compensating washer | 28i | Stop sleeve |
| 24 | Bearing cap | 28k | Sealing ring |
| 25 | Radial sealing ring | | |

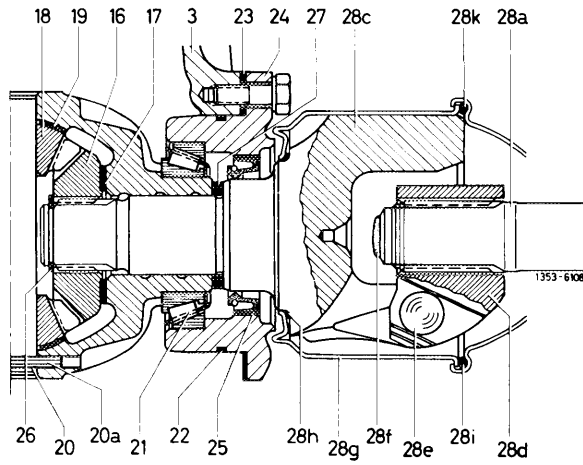

Layout of rear axle center piece without lateral bearing caps

- | | |
|----|----------------------|
| 12 | Differential housing |
| 35 | Locking ring |
| 36 | Spacing ring |
| 37 | Rear axle shaft |

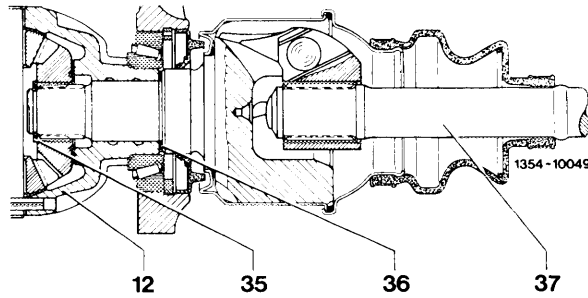

Note

Thoroughly clean rear axle housing in range of bearing cap, so that no dirt can enter rear axle housing.

Removal

- 1 Completely remove rear axle shaft at respective end (35–620).
- 2 Force radial sealing ring out of bearing cap by means of a screwdriver.

Rear axle center piece with lateral bearing caps

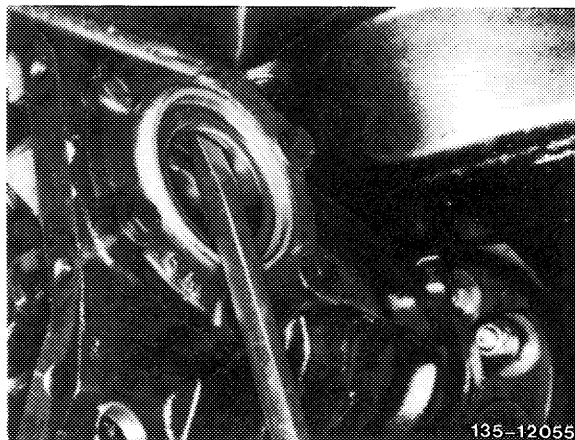

Rear axle center piece
without lateral bearing cap

29 Radial sealing ring

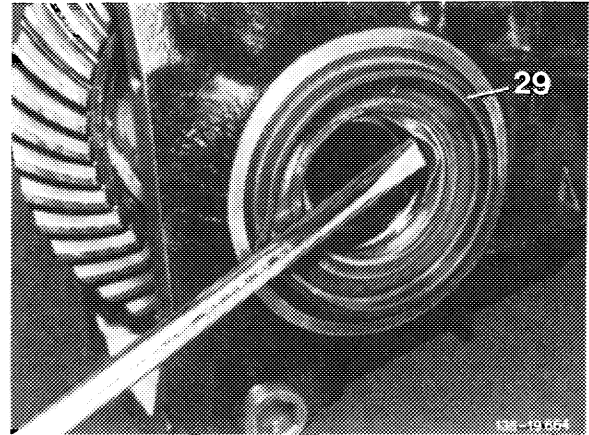

3 Check running surface for radial sealing ring on inner spider and renew rear axle shaft, if required.

Note: Starting November 1979 only radial sealing rings with alternate thread for oil return together with rubber-coated sheet-metal jacket will be available (B, arrows). They can be used at the left and right. This will eliminate ground thread on rear axle shafts.

- A = Radial sealing ring without thread (1st version)
- B = Radial sealing ring with alternate thread and rubber-coated sheet-metal jacket (2nd version)

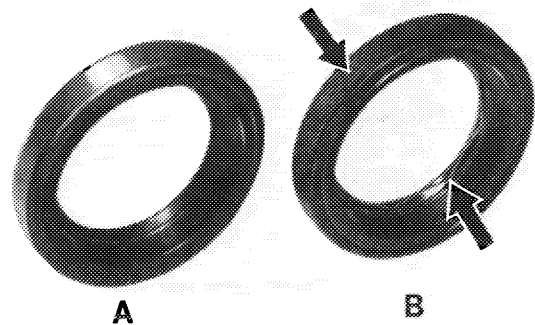

135-17049

Installation

Rear axle center piece with lateral bearing caps

4 Knock-in radial sealing ring with 65 mm OD by means of installer, until installer is flush with bearing cap.

Note: Coat radial sealing ring together with rubber-coated sheet-metal jacket on OD with rubber sliding compound "naphthalene H or hypoid gear oil".

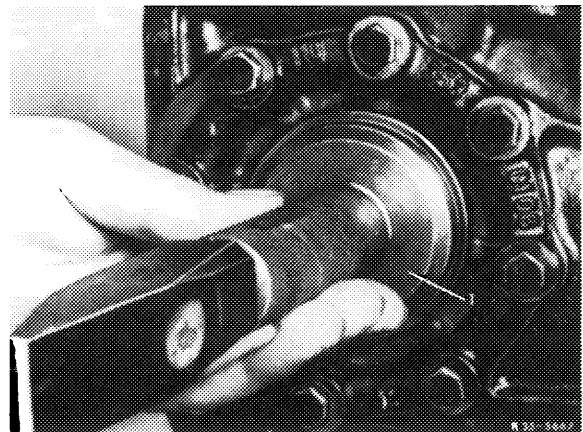

Attention!

On vehicles with large rear axle center piece there are 2 versions of bearing caps for radial sealing rings with 65 mm dia.

On 1st version, push radial sealing ring inwards until punch rests against lug for dirt labyrinth of bearing cap.

Radial sealing ring correctly inserted

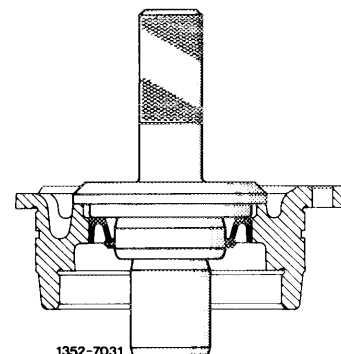

1352-7031

On 2nd version, push radial sealing ring inward until punch is flush with lower edge of chamfer (lug for dirt labyrinth is made shorter) of bearing cap.

To avoid excessive pressure, use spacing ring made according to drawing.

Radial sealing ring correctly inserted!

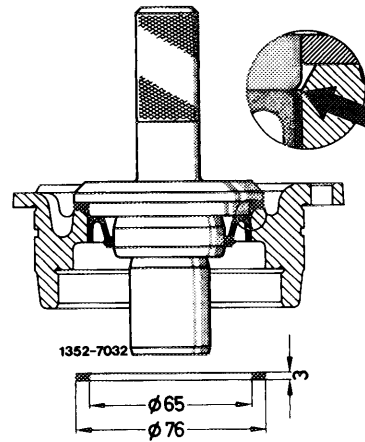

Radial sealing ring wrongly inserted!

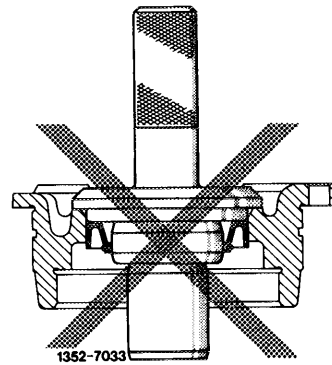

5 Press radial sealing ring of 81 mm OD into bearing cap until installer rests against cap.

Note: Coat radial sealing ring together with rubber-coated sheet-metal jacket on OD with rubber sliding compound "naphtalene or hypoid gear oil".

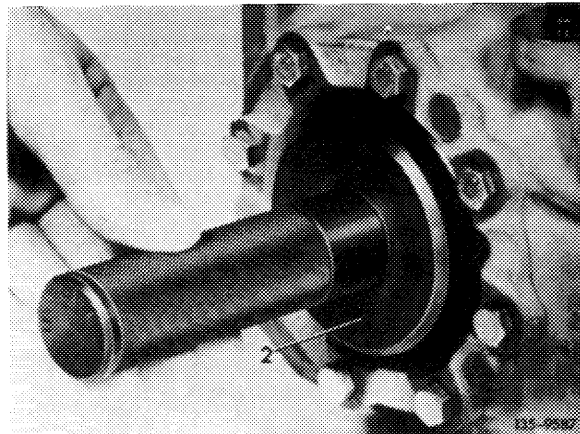

Rear axle center piece without lateral bearing caps

6 Coat radial sealing ring at OD with rubber sliding compound "naphtalene H or hypoid gear oil" and knock-in by means of installer, until installer (49a) rests against rear axle housing (54).

- 11 Tapered roller bearing
- 12 Transmission housing
- 26 Locking ring
- 29 Radial sealing ring
- 049a Installer
- 54 Rear axle housing

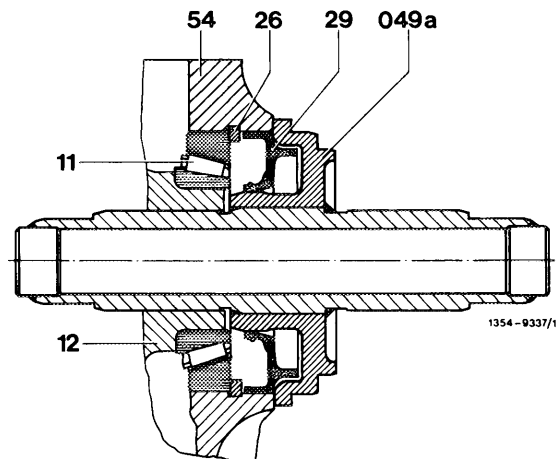

7 Install rear axle shaft complete with spacing ring. For this purpose, use a new locking ring between spider and side gear (35–620).

8 Check end play between inner spider and differential housing.

There should be no noticeable end play; the locking ring should just barely turn in groove. If required, install thicker or thinner spacing ring.

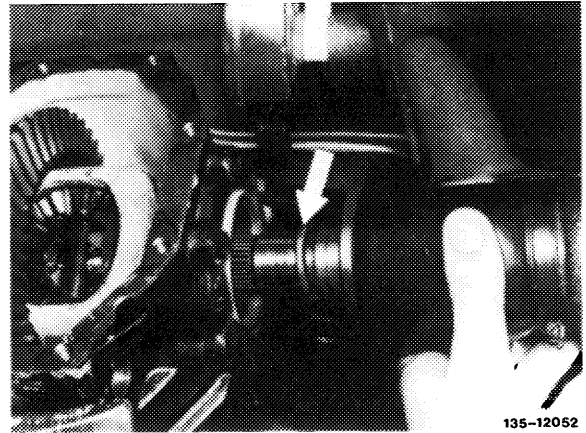

9 Fill rear axle housing with oil up to level of filler hole.