

## 35-680 Removal and installation of ring-shaped weight on inner joints of rear axle shafts

Distance	Model	Distance mm	Remarks
Distance between beaded edge and ring-shaped weight	107.045	23-24	1st version up to August 1981
	126.02		1st version -- if required only
	126.032/033		--
	126.02	13-14	2nd version if required only
	107.045 126.036/37	19-20	2nd version starting September 1981
Distance between hex. screw head and ring-shaped weight	107.046	9-10	--
	126.036/37		1st version up to August 1981

### Tightening torque

Nm

Hex. socket screw for fastening ring-shaped weight to rear axle shaft

20

### Note

To reduce wheel assembly noise (whining) of rear axle center piece, the inner joints of the rear axle shaft are provided with split ring-shaped weights. On model 126.036/037, 107.045/046, 126.032/033 starting September 1981 standard and on model 126.032/033 up to August 1981 optional.

On model 126.02 optional.

Removal and installation of ring-shaped weights are described on one side only.

### Removal

1 Loosen hex. socket screws and remove together with self-locking hex. nuts and split ring-shaped weight.

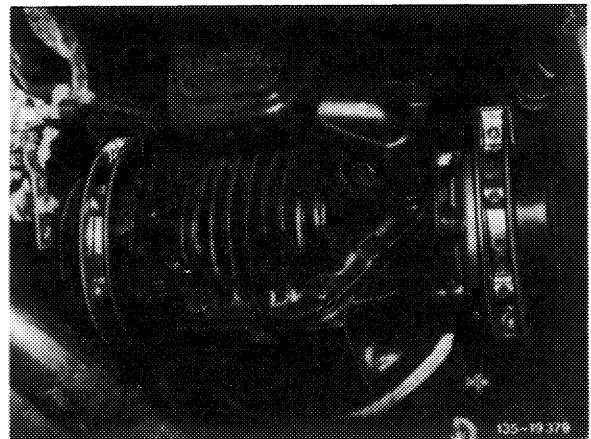

2 Check rubber (28p) in ring-shaped weight halves for cracks and replace, if required.

3 Clean protective sleeve of inner joints along circumference.

### Installation

---

4 Force rubber (28p) into ring-shaped weight halves (28o).

28o Ring-shaped weight halves  
28p Rubber  
28r Hex. socket screw  
28s Self-locking hex. nut

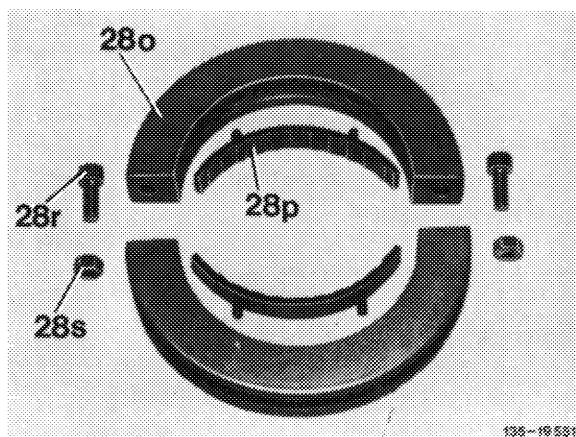

5 Connect ring-shaped weight halves by means of a hex. socket screw, while screwing-on self-locking hex. nut for one thread only.

### Attention!

Renew self-locking nuts on principle.

6 Twist ring-shaped weight halves in relation to each other (open up) and insert from the front over inner joint.

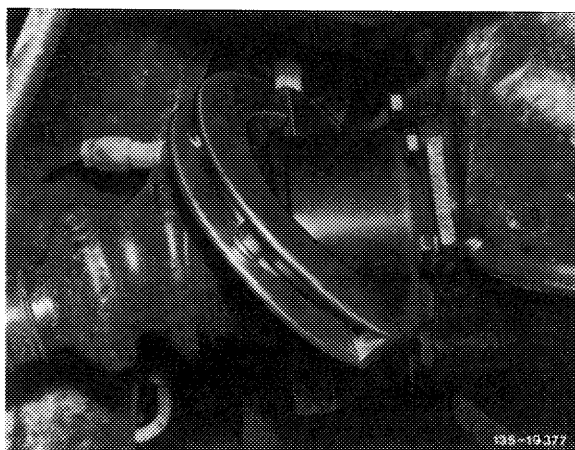

7 Replace second hex. socket screw with a self-locking hex. nut, but do not yet tighten.

8 Align ring-shaped weight in such a manner that the specified distance from hex. screw heads of lateral bearing caps or from beaded edge of rear axle shaft to ring-shaped weight is provided.

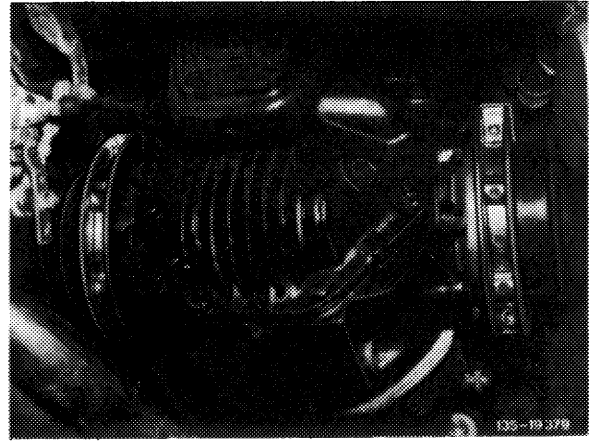

Model 107.045 up to August 1981  $a = 23-24$  mm

Model 126.02 1st version

Model 126.032/033

Model 107.045 starting September 1981  $a = 19-20$  mm

$a$  = distance between beaded edge and ring-shaped weight .

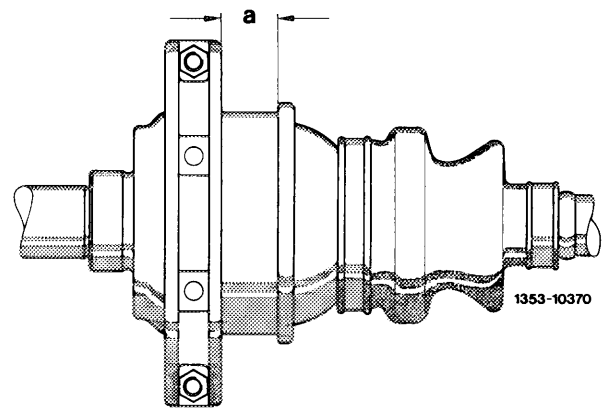

Model 107.046  $b = 9-10$  mm

Model 126.036/037 up to August 1981 1st version

$b$  = distance between hex. screw head and ring-shaped weight .

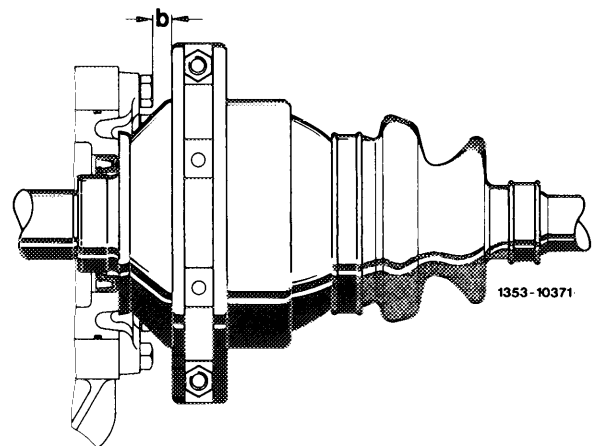

Model 126.02 2nd version  $c = 13-14$  mm

$c$  = distance between beaded edge and ring-shaped weight.

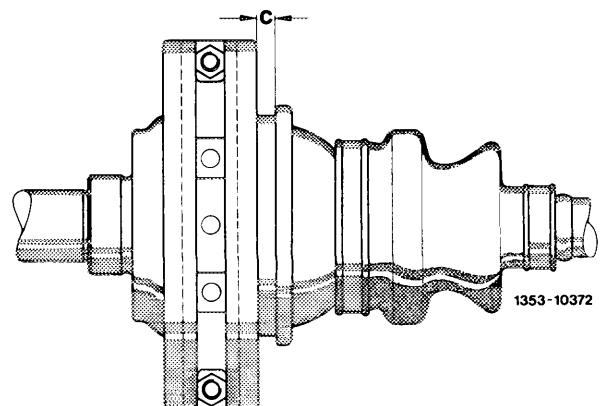

Model 126.036/037  $d = 19-20 \text{ mm}$   
starting September 1981 2nd version

$d$  = distance between beaded edge and ring-shaped weight.

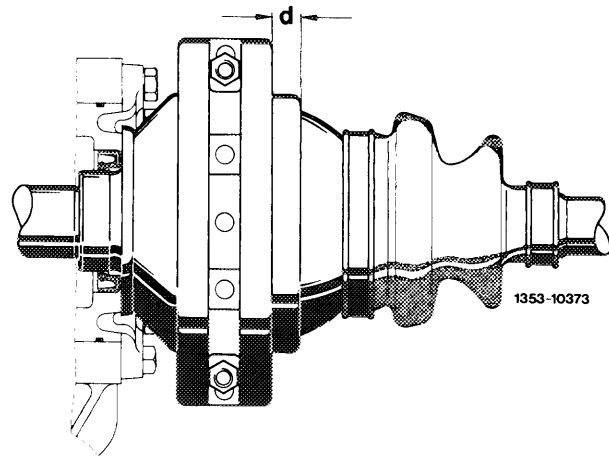

**Attention!**

On righthand rear axle shaft make sure that enough clearance is available between ring-shaped weight and fuel delivery hose. If required, turn connection of fuel line accordingly (arrow).

9 Tighten hex. socket screws to a tightening torque of 20 Nm.

