

42–100 Removal and installation of caliper on front axle

Data

| | |
|----------------------------|-----------------|
| Caliper make | Teves Bendix |
| Caliper piston dia. | 60 |
| Shaft width for brake pads | 90 + 0.15 |
| Disc contact width "a" | 16.5 |

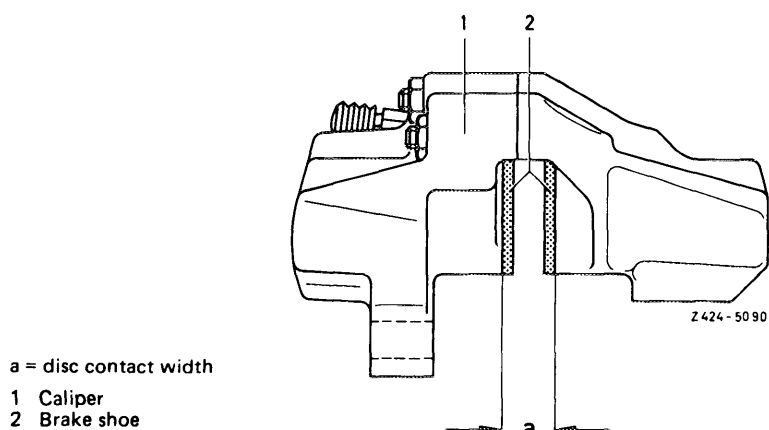

| | |
|--|-----|
| Tightening torque | Nm |
| Self-locking fitted hex bolt for attaching caliper to steering knuckle | 115 |

Conventional tool

| | |
|----------------------------------|---|
| Open double box wrench 9 x 11 mm | e.g. made by Hazet, D-5630 Remscheid, order No. 612 |
|----------------------------------|---|

Note

For loosening and tightening brake lines, use conventional open double box wrench only.

Starting September 1979, the brake hose installation for front wheel brakes has been changed. The brake hose holders on frame side member have been given a different location and the brake hoses themselves were shortened from 360 to 340 mm. To indicate the difference, the fittings of the modified, shorter brake hoses (2nd versions) have been given a hex. head with 17 mm width over flats (brake hose 1st version = 14 mm width over flats).

Spare bodies, front ends and side members are now supplied with modified brake hose holders only. In the event of repairs, make sure that the shorter brake hose with the 17 mm fitting is used. The brake lines to front wheel brake should be either replaced or converted to modified location of brake hose holder.

Removal

- 1 Pump brake fluid out of front brake circuit through an open bleeder plug.
- 2 Loosen brake hose (7) on brake line (4), then close brake hose and brake line immediately with rubber plug.

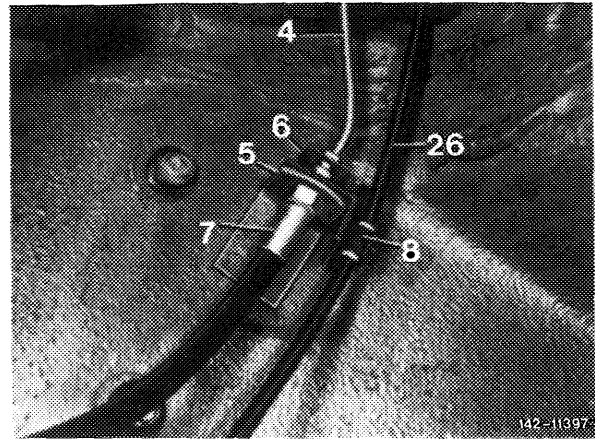

- 3 Pull cables of clip sensors (25) out of plug connection (26).

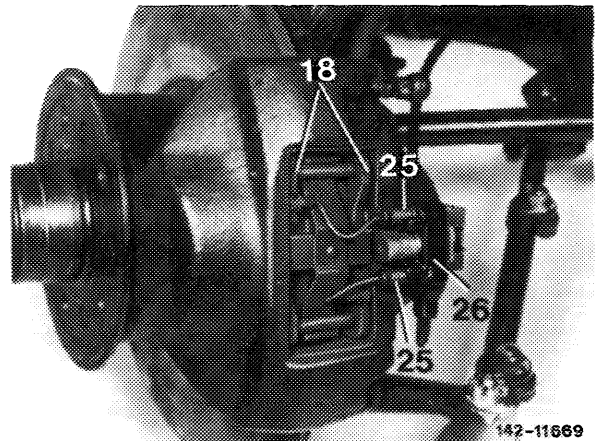

Plug connection 1st version

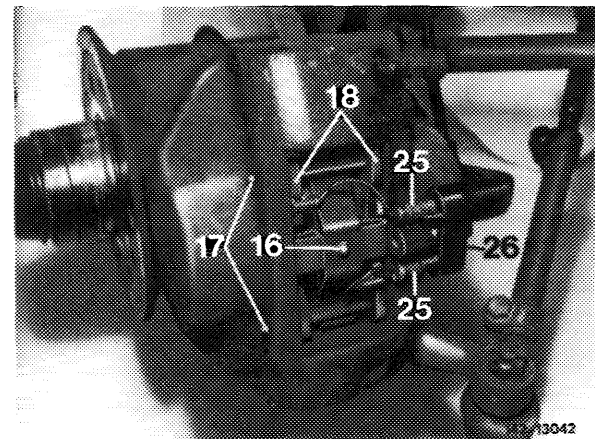

Plug connection 2nd version

- 4 Loosen plug connection (26) with cable holder (27) and brake hose (16) from caliper (2). Close connection on brake hose and on caliper with rubber plug.
- 5 Unscrew fitted hex bolts (3). Then remove caliper from steering knuckle (6).

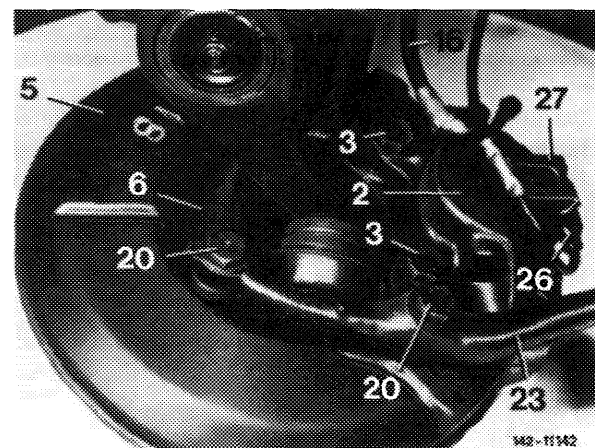

Installation

Attention!

When installing a new caliper, observe the following:

The calipers of **one axle should have the same piston dia.** In addition, only calipers of the same manufacturer may be installed on one axle.

Starting September 1979, modified calipers are installed with linings 17.5 mm thick.

In the event repairs proceed as follows:

Calipers for brake pads 15 mm thick are no longer available as spare parts. When exchanging calipers of vehicles manufactured at an earlier date, conversion to the brake pad version 17.5 mm thick is required. When replacing the caliper on one side only, a caliper for brake pads 17.5 mm thick may also be installed. Such a caliper combination permits the installation of a repair kit with brake pads 15 mm thick only.

- 1 Brake disc
- 2 Caliper
- 3 Self-locking fitted hex. bolt
- 5 Cover plate
- 6 Steering knuckle
- 9 Self-locking hex. socket screw
- 10 Front wheel hub
- 25 Clip sensor
- 26 Plug connection
- 27 Cable holder
- 28 Hex. bolt

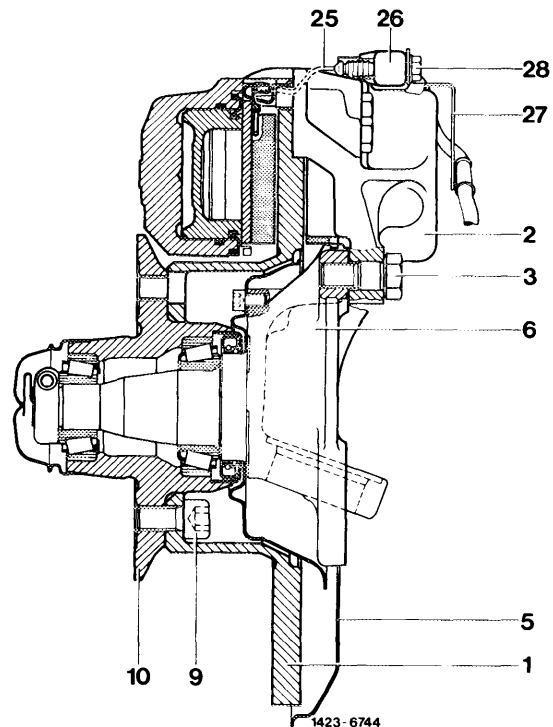

6 Attach caliper to steering knuckle (6) using new self-locking fitted hex bolts (3). Tighten fitted hex bolts to 115 Nm.

Note: Self-locking fitted hex. bolts may be used only once.

If the tightening torque of the new self-locking hex bolts is very high, clean threads in steering knuckle from remaining glue of micro-encapsulated bolts by means of an M 12 x 1.5 tap.

7 Attach plug connection (26), as well as cable holders (27) and brake hose (16) of 1st version, to caliper (2).

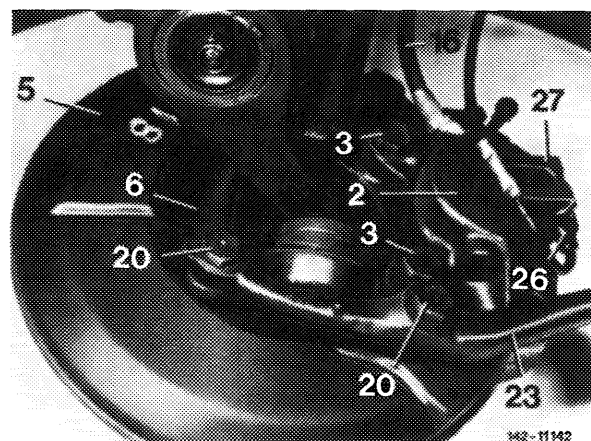

8 Insert cables of clip sensors (25) into plug connection (26).

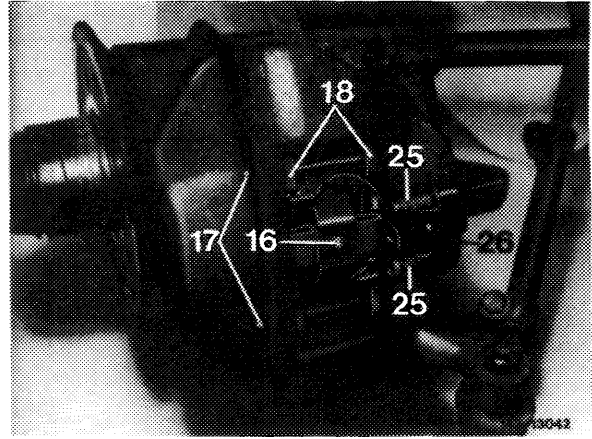

9 Connect brake line (4) to brake hose (7), making sure that the brake hose is not twisted.

Attention!

Holder (5) is provided with a double hexagon safety plate (8). Insert brake hose (7) into safety plate in such a manner that it will not wipe anywhere at left and right at full steering lock.

- 4 Brake line
- 5 Holder on underbody
- 6 Brake hose holder
- 7 Brake hose
- 8 Safety plate
- 9 Cap screw

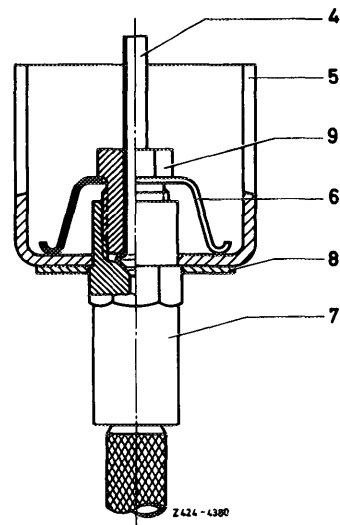

10 Bleed front axle brake circuit (42-010).

Attention!

Check brake system for leaks!

Upon bleeding, actuate brake pedal several times energetically to obtain the correct clearance between brake disc and brake pad. Then perform leak test with engine running by actuating the brake pedal several times at approx. 200-300 N. The established pressure should hold out for some time, brake pedal should not permit additional depression. Check all connections for leaks. Top-up brake fluid in expansion tank of tandem main cylinder, if required.