

42—155 Replacement of piston seal on rear axle caliper

Data

Caliper-make	Teves M 42	Teves	Bendix	Girling
Housing dia.	<u>41.99</u>		<u>37.99</u>	<u>38.17</u>
	42.03		38.03	38.22
Shaft width for brake pads	62 + 0.15			

Lubricant

ATE brake cylinder paste

Special tools

Impact puller

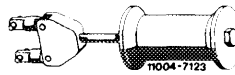

123 589 06 33 00

Puller for stuck brake pads

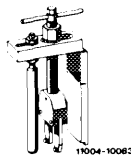

123 589 07 33 00

Piston resetting pliers



123 589 00 37 00

Piston rotating pliers



000 589 50 37 00

Pliers for fitting dust cap



000 589 49 37 00

Check gauge for piston position

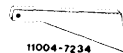

000 589 35 23 00

Conventional tool

Open double box wrench 9 x 11

e.g. made by Hazet, D-5630 Remscheid
order No. 612

Note

Do not separate the two halves of the caliper since the fastening bolts are tightened to a definite torque by the manufacturer.

When replacing piston seal in Bendix caliper, make sure that the pressed-on ring is not forced off when dust cap is removed (refer to arrow). The ring is not available as a spare part.

If the ring is corroded, experience has shown that the cylinder bore is also damaged. In such a case, exchange complete caliper.

Removal

- 1 Remove brake pads (42-160).
- 2 Force dust cap (9) from housing by means of a screw driver.

Teves version

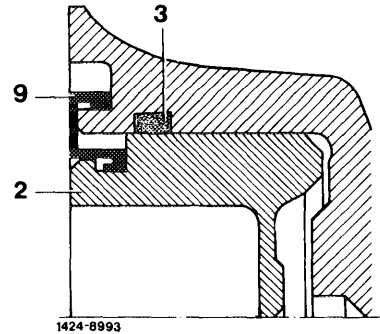

Bendix version

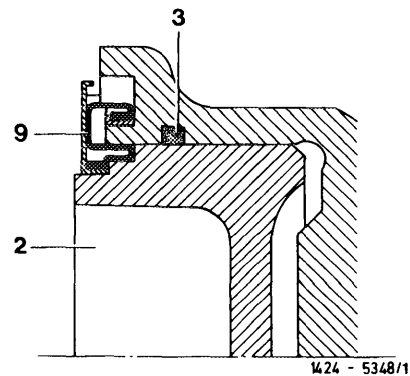

Girling version

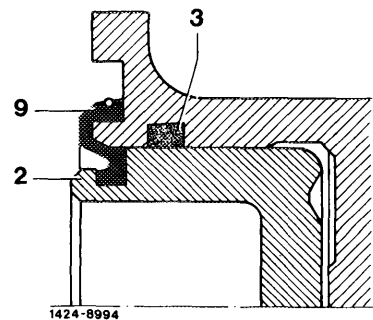

- 3 Hold one piston (2) in caliper with piston resetting pliers (018). Then press-out opposite piston by means of compressed air of approx. 0.5 bar.

Note: If pistons are rusted down, install new caliper.

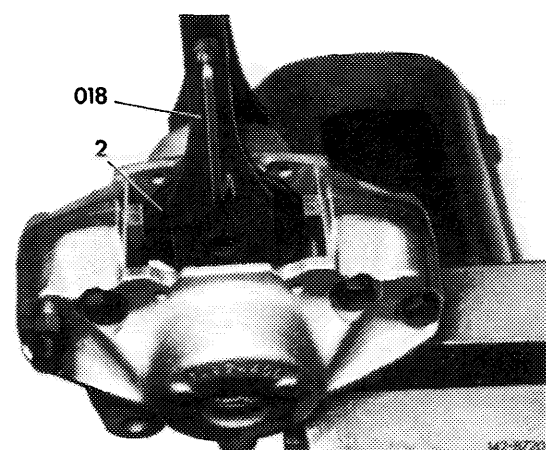
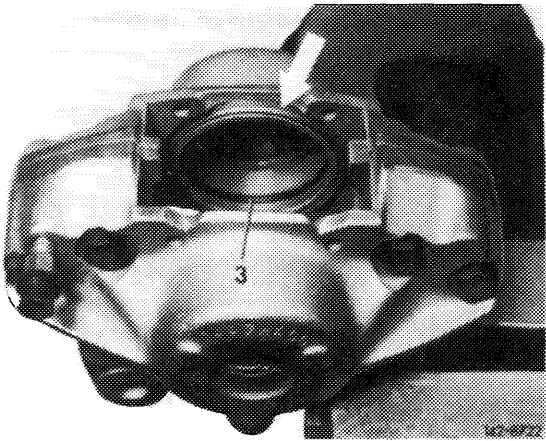

4 Remove piston seal (3) from groove of cylinder bore.

- Teves version
- 1 Caliper
 - 2 Piston
 - 3 Piston seal
 - 4 Brake pad
 - 5 Holding pin
 - 6 Brake disc
 - 9 Dust cap
 - 10 Cross spring

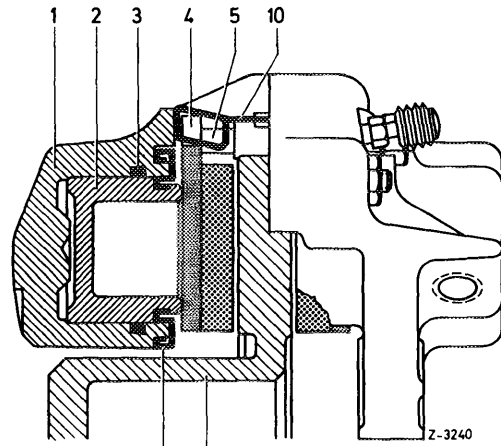

- Bendix version
- 1 Caliper
 - 2 Piston
 - 3 Piston seal
 - 4 Brake pad
 - 5 Holding pin
 - 6 Brake disc
 - 9 Dust cap
 - 10 Lining holding spring

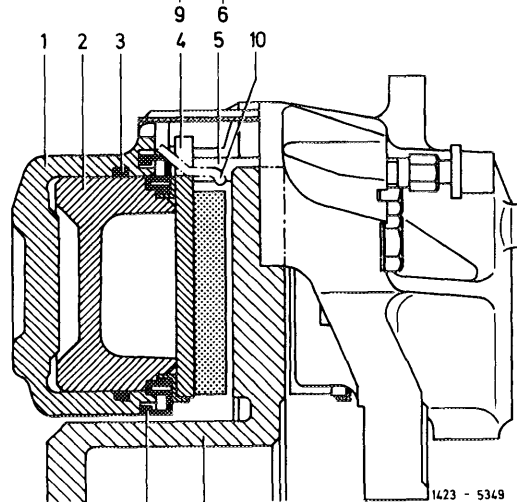

- Girling version
- 1 Caliper
 - 2 Piston
 - 3 Piston seal
 - 4 Brake pad
 - 5 Holding pin
 - 6 Brake disc
 - 9 Dust cap
 - 10 Lining holding spring

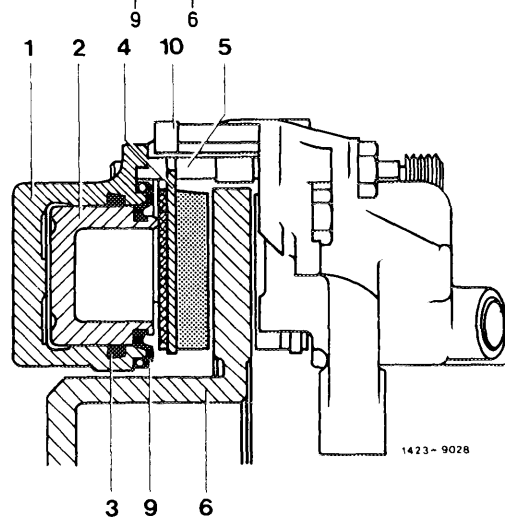

Inspection and repair

5 On Bendix caliper, remove heat shield (7) from piston.

6 Remove deposit on piston with a soft brass-wire brush or a rough cleaning cloth. Do **not** work on piston with polishing cloth or emery cloth, since this might damage the chrome-plated surface. Replace piston if chrome surface is damaged.

7 Check cylinder bores of caliper for wear. Replace complete caliper if bores are scored or rusted. Remove small, minor rust spots in bore with polishing cloth, heavier rust spots in front of piston seal groove with fine emery paper (380 to 500 grain).

Installation

8 Coat new piston seal (3) slightly with ATE brake cylinder paste and insert into groove of cylinder bore.

Note: When reconditioning Bendix caliper, make sure of a firm and perfect seat of pressed-on ring (refer to arrow).

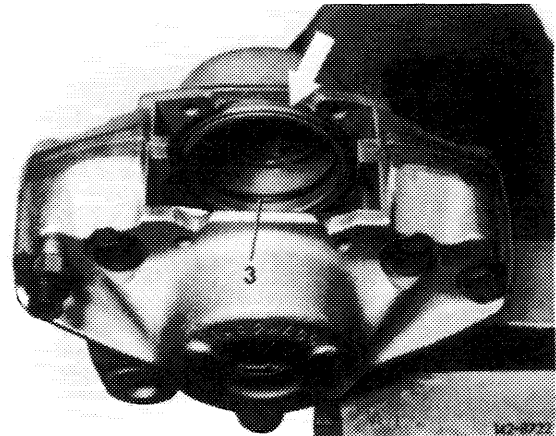

9 Insert piston (2) into bore of caliper. Check position of piston in caliper with piston gauge (019).

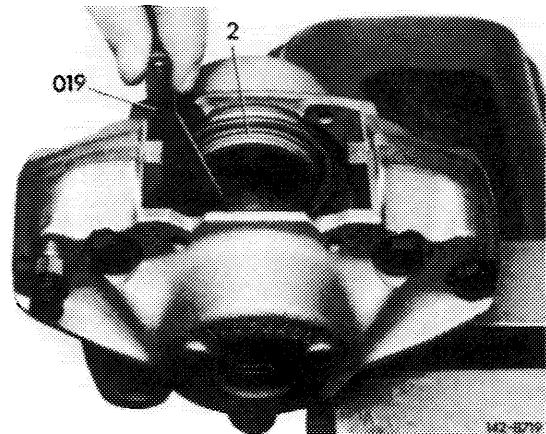

Note: When installing piston, watch out for different piston versions.

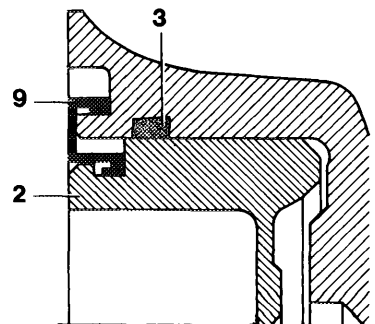

Teves version

1424-8993

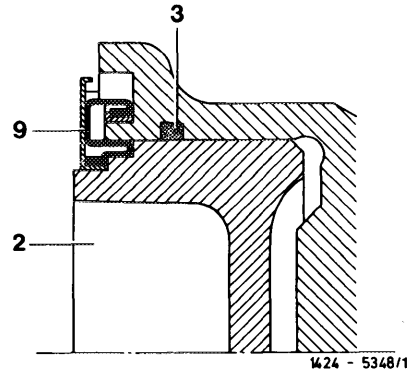

Bendix version

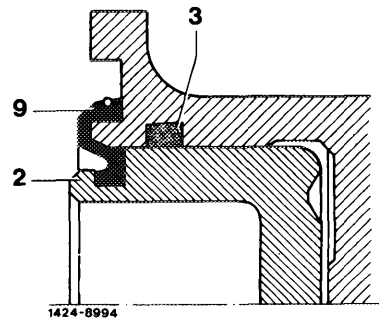

Girling version

10 If required, move piston into correct position by means of piston rotary pliers (020).

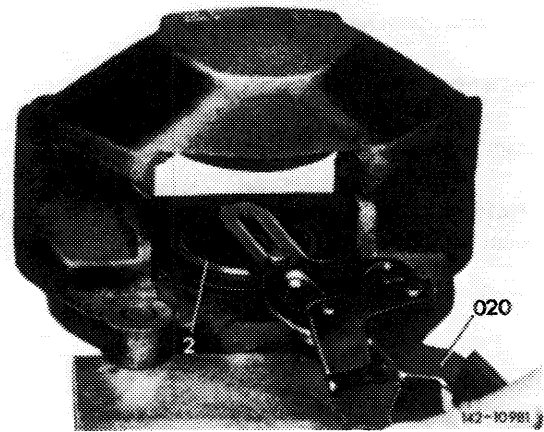

Attention!

Insert piston in such a manner that with the caliper installed the elevation (marked in black) on piston is facing upwards. This elevation serves for one-sided contact of the brake pads while braking, which will reduce the tendency to squeal.

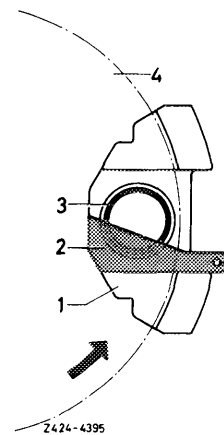

11 On Teves caliper, mount dust cap (9) on piston (2) and position against collar of caliper.

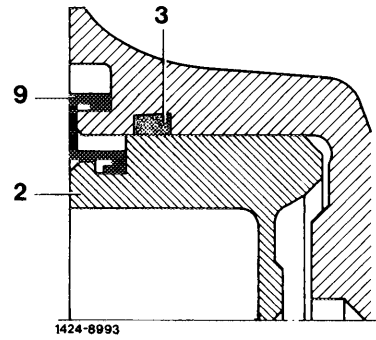

12 Press dust cap (9) on collar of caliper by means of pliers (026) and pertinent discs (027).

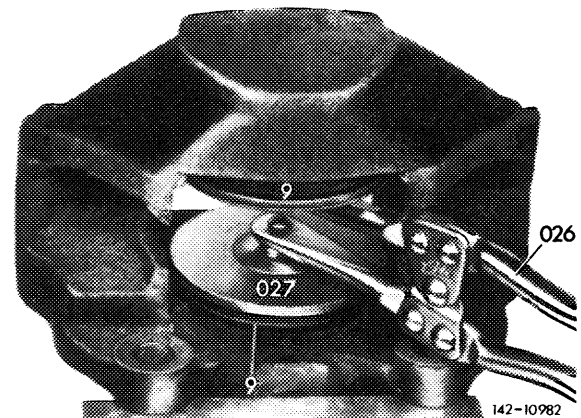

13 On Bendix caliper, press heat shield (7) on piston in accordance with piston position.

Attention!

The elevation on piston should protect at least 0.1 mm beyond heat shield.

Note: The rear wheel caliper made by Teves has no heat shield.

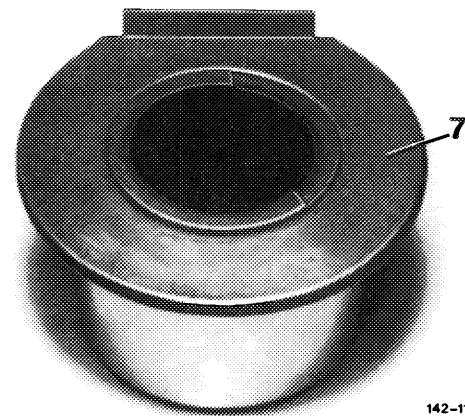

14 Place dust cap (9) on piston (2).

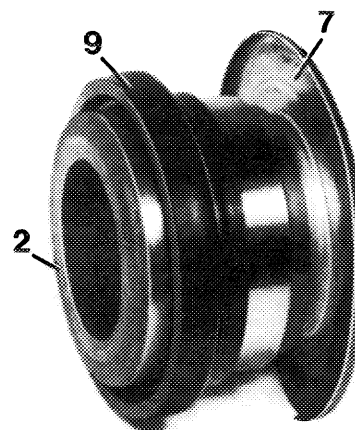

15 Mount dust cap (9) on collar of caliper with a blunt assembly needle. Then push piston completely back until dust cap (9) is perfectly seated on piston collar.

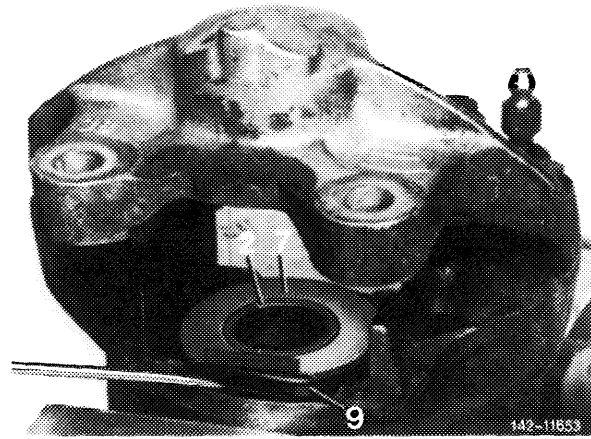

16 On Girling caliper, mount dust cap (9) on piston (2).

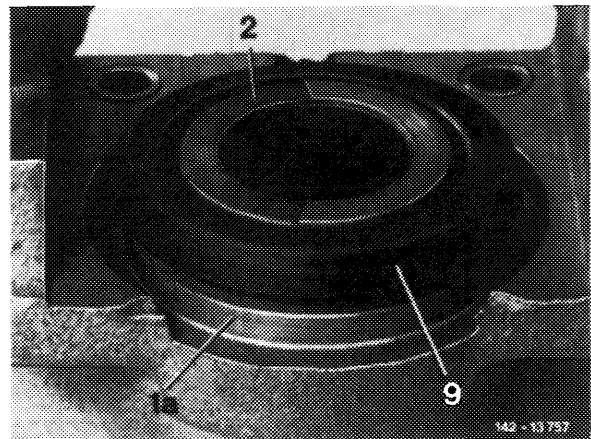

17 Push dust cap (9) over web (1a) of caliper and attach with clamping ring (10).

18 Install brake pads into caliper (42-160).

