

## 42–228 Removal and installation of brake disc on rear axle

### Data

Thickness of brake disc	10
Wear limit	8.3
Brake disc dia.	279 ± 0.2
Fitted bore dia.	67.00 67.05
ID for parking brake	160 ± 0.2
Lateral runout	max. 0.12

### Lubricant

Molykote Paste U	Molykote Paste G Rapid	Liqui Moly Paste 36
------------------	------------------------	---------------------

### Tightening torque

	Nm
Self-locking hex. bolt for attaching caliper to wheel carrier of rear axle	90

### Special tools

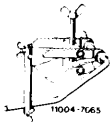
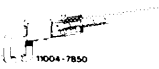
Measuring device for concentricity of brake disc		001 589 63 21 00
Slide gauge for measuring thickness of brake disc		126 589 00 19 00

## Note

When checking, proceed as follows:

- a) Measure thickness of brake disc between cover plate and caliper, or with brake pads removed, in inspection hole by means of slide gauge.
- b) Check visually.

If cracks are rather large (not measurable), if score marks are deeper than 0.5 mm and when wear limit is attained, replace brake discs.

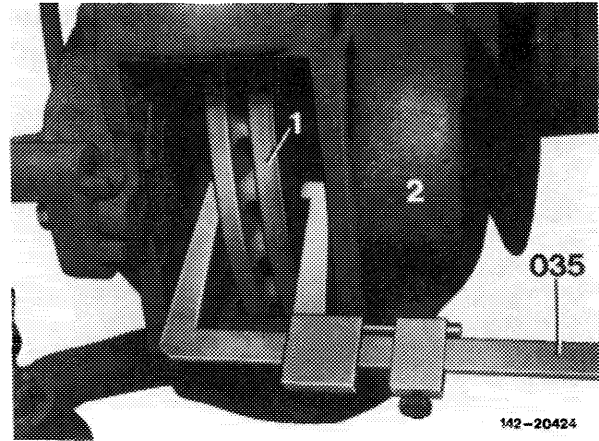

## Removal

- 1 Caliper
- 2 Self-locking hex. bolt
- 4 Wheel carrier
- 5 Inside tapered roller bearing
- 6 Radial sealing ring
- 7 Sealing ring
- 8 Slot nut
- 9 Spacing sleeve
- 10 Brake cable control
- 11 Cover plate
- 12 Brake disc
- 13 Brake carrier
- 14 Fitted pin
- 15 Rear axle shaft flange
- 16 Outside tapered roller bearing
- 17 Dust cap
- 18 Radial sealing ring
- 19 Cover ring

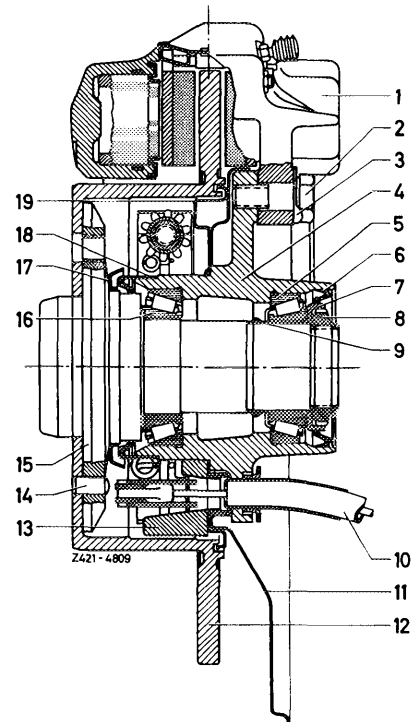

- 1 Unscrew hex. bolts (2) and remove caliper from wheel carrier (4).

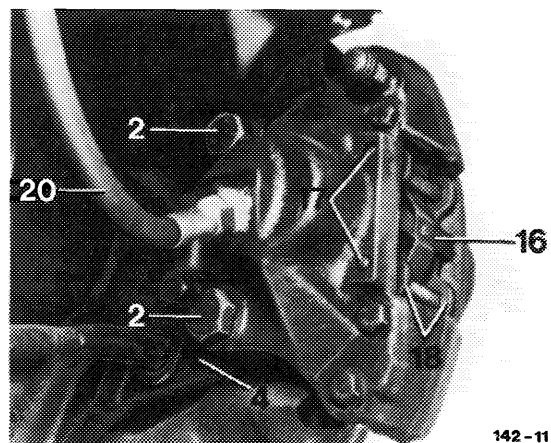

2 Attach caliper and brake hose to torsion bar by means of a suitable hook.

**Note:** The hook must be self-made. Do not subject brake hose to tensile stress.

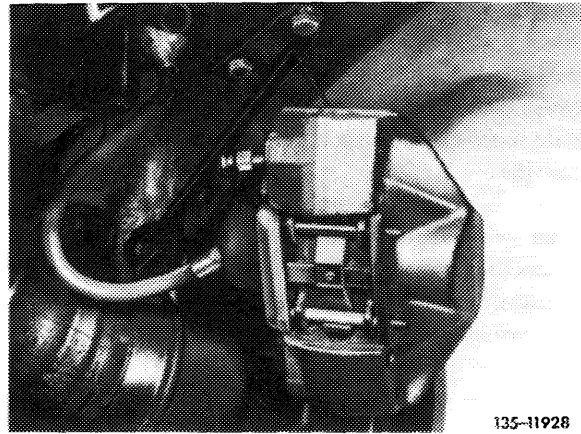

135-11928

3 Remove brake disc (12) from rear axle shaft flange (15).

Loosen stuck brake discs from seat of rear axle shaft flange by light blows with a plastic hammer. Make sure that the parking brake is completely released.

### Installation

4 Coat fitted seat of rear axle shaft flange with a heat-resistant long-term lubricant (Molykote Paste „U“, Molykote Paste G Rapid, Liqui Moly Paste 36), so that the brake disc can be easily removed from rear axle shaft flange later on.

**Note:** Spare brake discs are protected against corrosion by means of nitrocellulose paint. For this reason, these brake discs must be cleaned with a solvent prior to installation. Make sure that safety rules are observed.

5 Place brake disc (12) on rear axle shaft flange. Make sure that the fitted pin (14) enters correctly into brake disc.

6 Attach caliper with new self-locking hex. bolt to wheel carrier. Tighten hex. bolts to 90 Nm (42–120).

**Note:** Self-locking hex. bolts M 12 x 30 may be used only once.

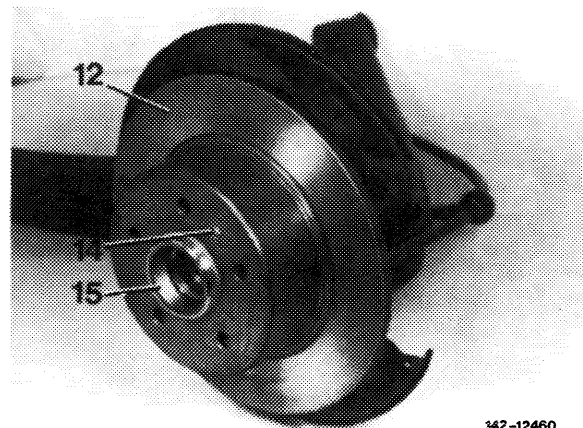

142-12460

**Attention!**

**Prior to moving-off, operate brake pedal energetically several times** to establish the correct clearance between brake disc and brake pad. Then top-up brake fluid supply in expansion tank of tandem main cylinder.

**Note:** If during a trial run (mainly after driving around a bend) a different pedal travel is observed, measure lateral runout of brake disc on OD. Simultaneously check rear axle shaft flanges for vertical and lateral runout and wheel bearing play in semi-trailing arm and adjust, if required (35–130).

If the lateral runout of the brake disc is too high, renew brake disc.