

## 42–315 Disassembly, inspection and assembly of stepped tandem main cylinder

---

### Data

		Push rod circuit	Floating circuit
Dia.	inches	15/16	3/4
	mm	23.81	19.05
Housing bore dia.		23.81	19.05
		23.86	19.10
Wear limit		23.92	19.16
Permissible out-of-round of bore			0.03
Piston dia.		23.77	19.01
		23.74	18.97
Wear limit		23.66	18.90
Piston clearance			0.06–0.26
Stroke		15	17

### Lubricants

Silicone grease

Brake cylinder paste

### Tightening torques

	Nm
Stop screw	5–8
Closing plug	15–30
Switch	15–20

### Self-made tool

Assembly pin refer to illustration item 17, note

### Note

---

For reconditioning, make sure that the housing of the main cylinder and the repair kit should come from the same manufacturer.

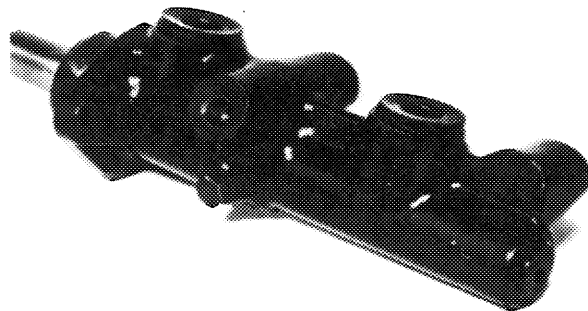

142-11670

Stepped tandem main cylinder

- 1 Container plug
- 3 Piston (push rod circuit)
- 4 Stop washer
- 5 Locking ring
- 6 Secondary and vacuum sleeve
- 7 Intermediate ring
- 9 Filling washer
- 10 Primary sleeve
- 11 Supporting ring
- 12 Spring retainer
- 14 Connecting screw
- 15 Stop screw
- 17 Compression spring
- 18 Parting sleeve
- 20 Piston (floating circuit)
- 21 Compression spring
- 22 Housing
- A Leak hole
- B Filler hole
- C Compensating hole

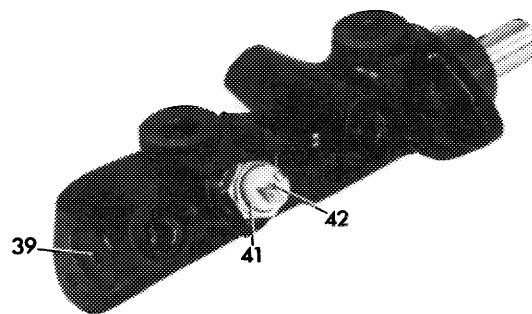
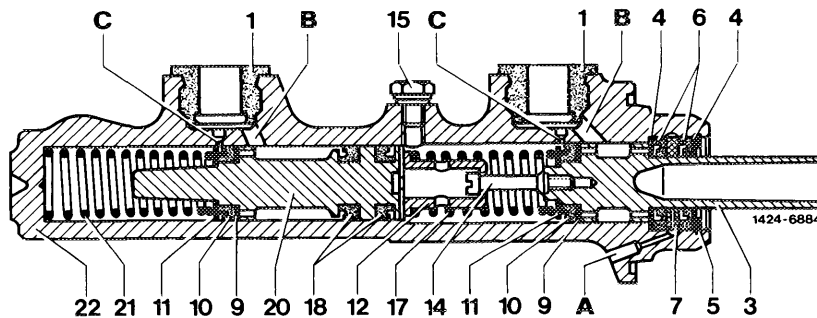

142-10793

Stepped tandem main cylinder with pressure difference warning indicator

- 3 Piston (push rod circuit)
- 20 Piston (floating circuit)
- 35 Control piston
- 36 Ring sleeve
- 37 Spring
- 38 Spring retainer
- 39 Screw
- 40 Sealing ring
- 41 Switch
- 42 Release pin

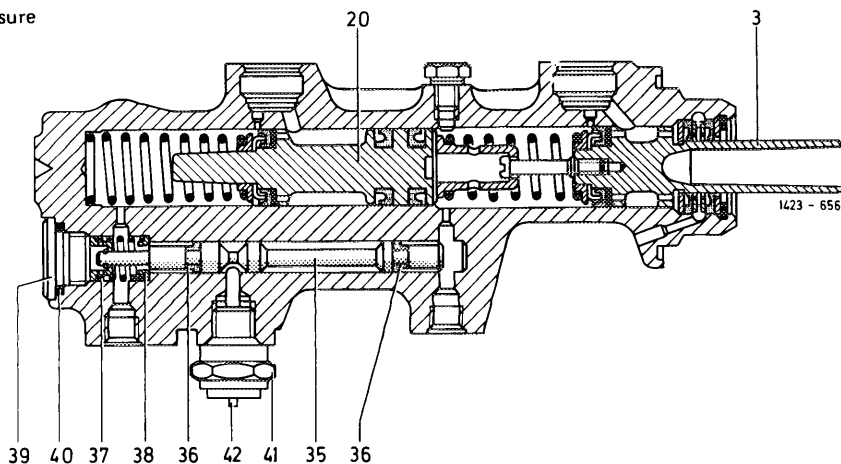

## Disassembly

---

- 1 Pull expansion tank and container plug from tandem main cylinder.
- 2 Push piston (3) slightly inwards by means of a mandrel, then unscrew stop screw (15) from housing and remove together with sealing ring.

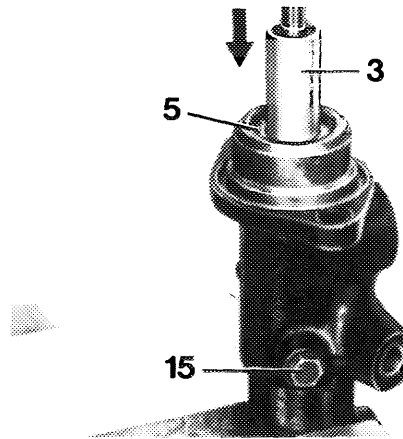

142 - 11753

- 3 Remove locking ring (5) from housing. Then remove piston (3) together with the two stop washers (4), the secondary and the vacuum sleeve (6) and the intermediate ring (7) from housing.

- 4 Knock out complete piston for floating circuit by knocking housing lightly against a wooden base.

- 5 On tandem main cylinder with pressure difference warning indicator, unscrew closing plug (39) and knock out control piston (35) as shown under item 4.

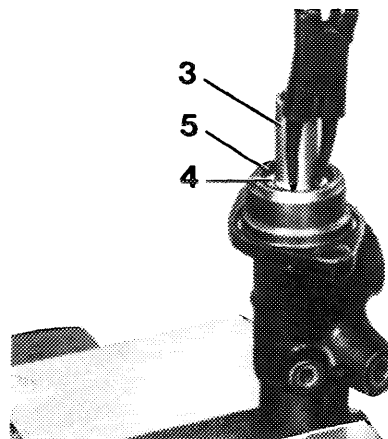

142 - 11752

- 6 Unscrew closing cover (25) and remove strainer.

**Note:** The contact insert (30) cannot be removed.

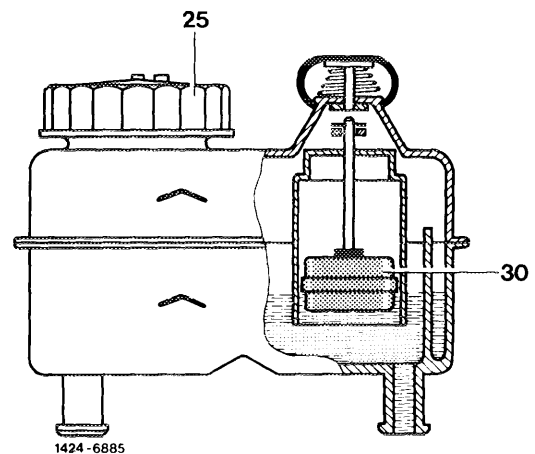

## Inspection

---

- 7 Clean all parts thoroughly in spirit of alcohol, making sure that all residues are flushed out of housing and expansion tank.

- 8 Check bores in housing for score marks and rust. Slight rust may be removed with polishing cloth.

**Housings presenting score marks or heavily rusted housings may not be finished.**

## Assembly

### Attention!

**(USA)** 1981 vehicles are provided with a light alloy tandem main cylinder instead of tandem main cylinder made of grey iron.

When mounting stop screw, make sure that the right sealing ring is used.

Grey iron version: copper sealing ring.

Light alloy version: aluminum sealing ring.

9 Slightly coat bore of housing with brake cylinder paste.

10 Remove secondary sleeve, vacuum sleeve, stop washers, intermediate ring, O-ring and sealing ring from assembly sleeve.

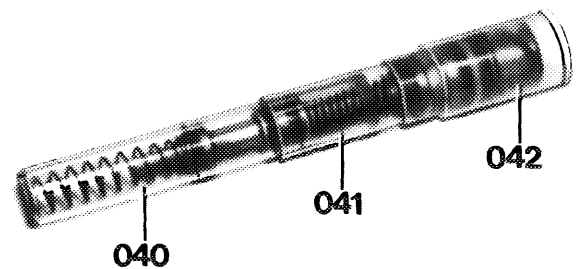

142-12081

11 Clamp housing slightly tilted with bore in downward direction. Remove assembly sleeve (040) including floating piston (19.05 dia.) from assembly sleeve (041) for push rod piston (23.81 dia.). Place assembly sleeve (040) into housing and slide piston into housing up to stop by means of a mandrel.

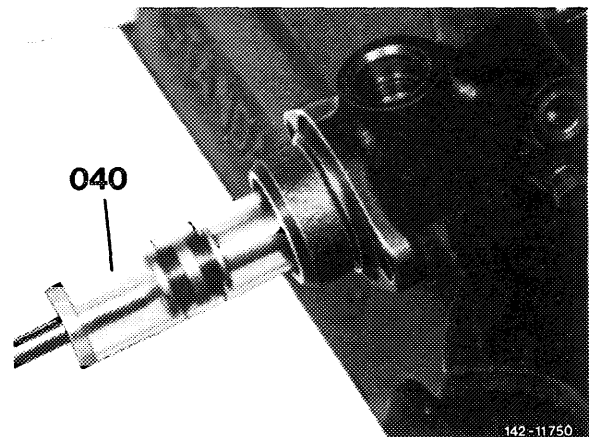

142-11750

12 Hold piston with mandrel, pull out assembly sleeve (040) until stop screw (15) with the new sealing ring can be installed.

Tighten stop screw (15) to 5–8 Nm.

13 Remove assembly sleeve (040).

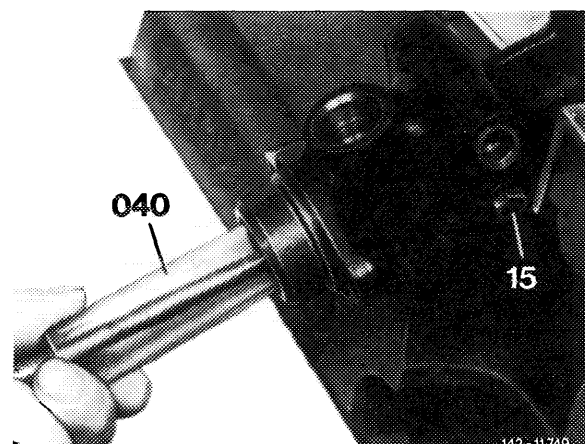

142-11749

14 Clamp tandem main cylinder in such a manner that cylinder bore is pointing upwards.

15 Remove assembly sleeve (041) including push rod piston (23.81 dia.) from assembly sleeve (042) for secondary seal. Insert assembly sleeve (041) into housing and slip piston (3) into housing by means of a mandrel.

16 Remove assembly sleeve (041).

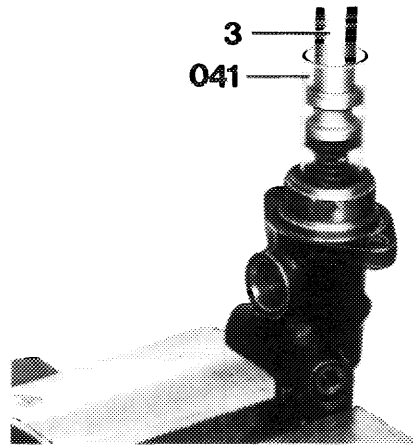

17 Push piston (3) in until the second collar of the push rod piston is behind the filler hole. Then insert assembly pin (045) into filler hole up to stop. Make sure that the push rod piston is not damaged.

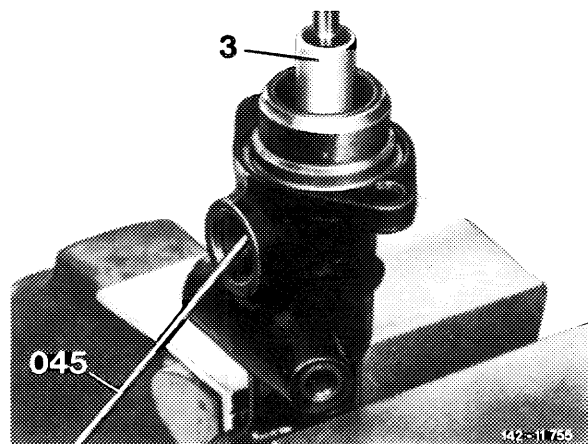

**Note:** The assembly pin (045) serves as a stop and must be self-made from steel according to the dimensions shown.

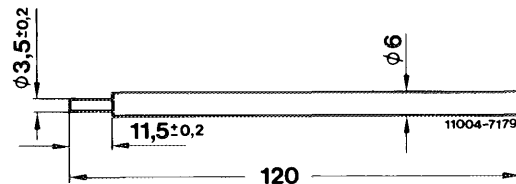

18 Place stop washer (8) on piston (3).

19 Slightly coat stem of piston (3) with silicone grease.

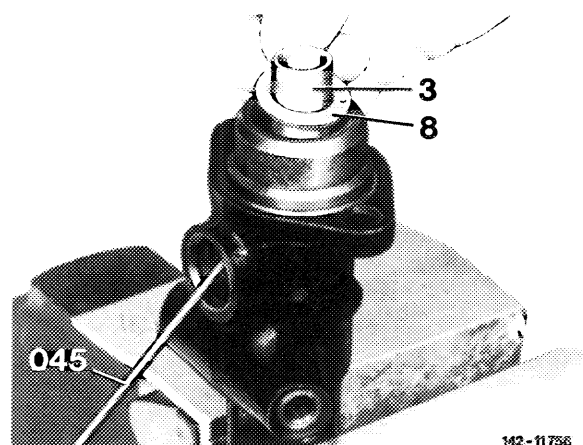

20 Coat secondary sleeve (6) with silicon grease, then mount on shaft of piston with sealing lip facing piston, hold in place and insert assembly sleeve (042) over sleeve up to stop.

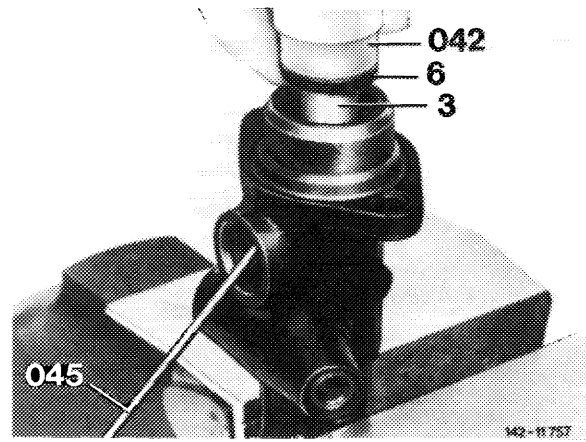

21 Slide assembly sleeve (042) with secondary sleeve (6) into bore of housing. Push secondary sleeve in downward direction with blunt portion of assembly sleeve (040). First pull up assembly sleeve (042) by height of sleeve, then remove both sleeves.

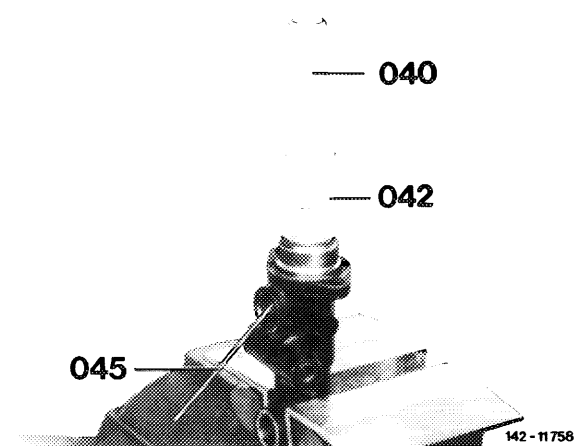

22 Insert intermediate ring (7) into housing, making sure that the bore in intermediate ring faces leak hole (A) in housing and push inwards with sleeve (040).

23 Install vacuum sleeve (6) as described in item 20 and 21.

24 Mount stop washer (8) as described in item 18.

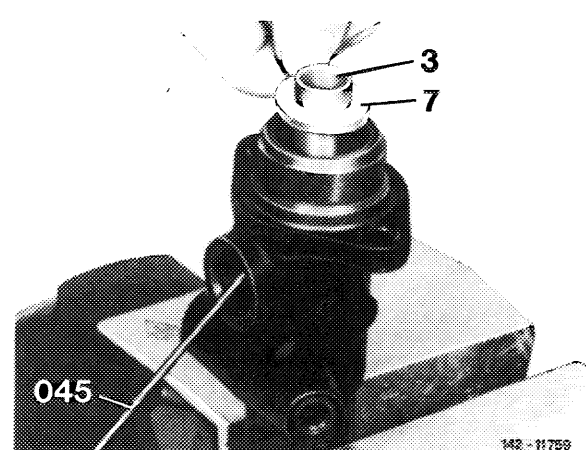

25 Insert locking ring (5), making sure that the ring is correctly seated in groove of housing. Then push piston downward and pull out assembly pin.

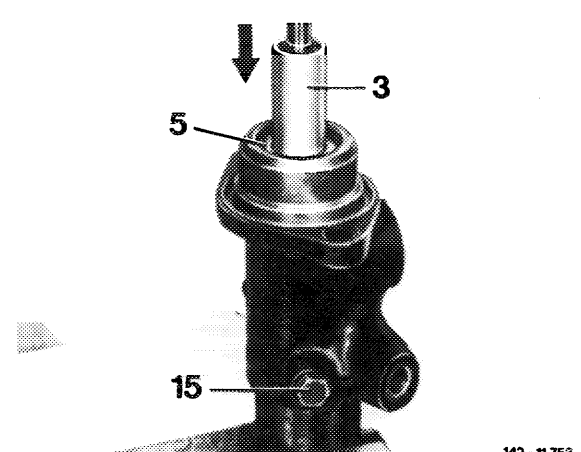

26 On tandem main cylinder with pressure difference warning indicator slip control piston (35) into housing. Make sure that the ring sleeve (36) is not damaged.

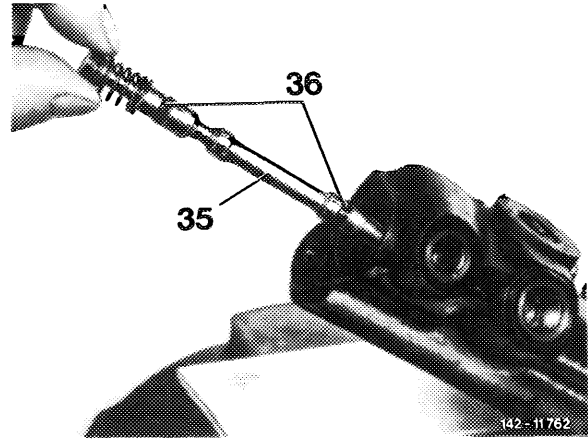

27 Screw-in closing plug (39) and tighten to 15–30 Nm.

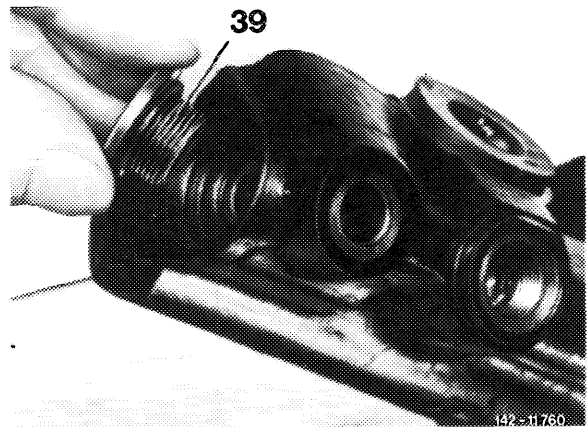

28 Screw switch (41) into housing and tighten to 15–20 Nm.

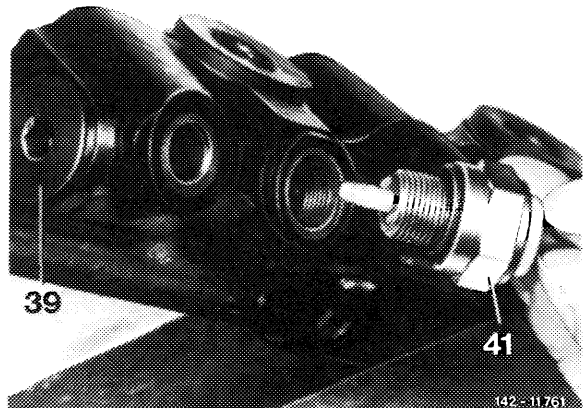

### Mount expansion tank

29 Insert strainer into container and screw-on closing cover.

30 Lightly coat container plug (1) with brake cylinder paste and push into housing.

31 Insert expansion tank (26) first into housing by means of a pipe connection, turn by 180° and push second pipe connection into housing. Watch out for perfect seat.

