

43–325 Checking brake booster

Data

Force at brake pedal	bar vacuum	Line pressure bar gauge pressure			
		Bendix B 90	Teves T 52/225	DBA 255 Teves T 52/1/255 Girling Girvac 80 Girling LS 80 ¹⁾	Teves T 52/225 T
N		9" single		10" single	10" double
50		10 – 17	4 – 8	9 – 14	2 – 12
100		25 – 36	21 – 28	26 – 35	28 – 40
150		42 – 55	38 – 48	44 – 55	54 – 68
200		58 – 73	55 – 68	61 – 75	80 – 97
250		74 – 81	73 – 81	79 – 97	105 – 125
300		79 – 86	78 – 85	90 – 101	132 – 140
Overlap between push rod piston of main cylinder and push rod of brake booster		0.2 – 1.2			

¹⁾ (USA) 1981

Special tool

Vacuum tester

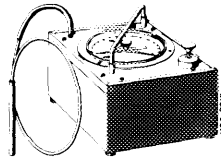

116 589 25 21 00

Conventional tools

Pressure tester

e.g. made by ATE, D-6000 Frankfurt/M
order No. 3.9305–1020.4

Pedal pressure meter

e.g. made by Hofmann Prüftechnik,
D-3210 Elze 1, order No. PKM 60

Self-made tool

Measuring connection

refer to illustration item 2, note

Checkup

- 1 Loosen vacuum line (3) on brake booster (1) and attach measuring connection (2) between line and brake booster.
- 2 Connect vacuum tester (030) to measuring connection (2).

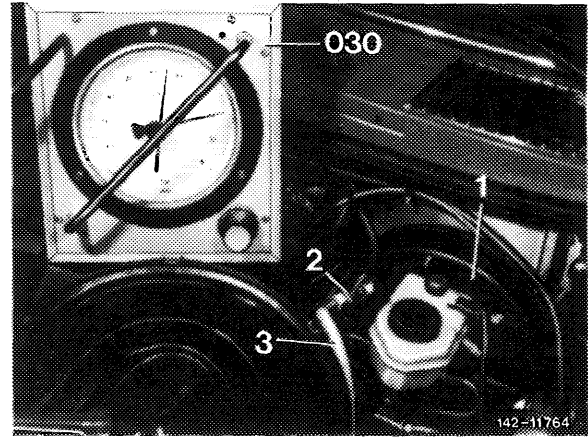

Note: The measuring connection is self-made according to specified dimensions, part 1, 3, 4, 5 and 6 are brazed to each other. For connection to brake booster, the pipe section and coupling nut of an old vacuum line may be used. Connection to vacuum line is made by means of a screw connection.

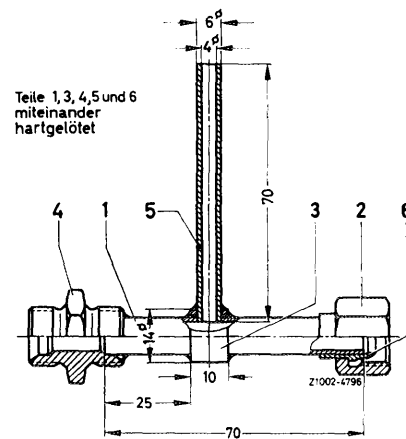

- 3 Connect pressure tester (051) to a caliper. For this purpose, unscrew bleed screw and screw-in connection (052). Then bleed pressure tester.
- 4 Attach pedal force meter to brake pedal.
- 5 Run engine and establish a vacuum of 0.75–0.8 bar by accelerating and suddenly releasing accelerator pedal.

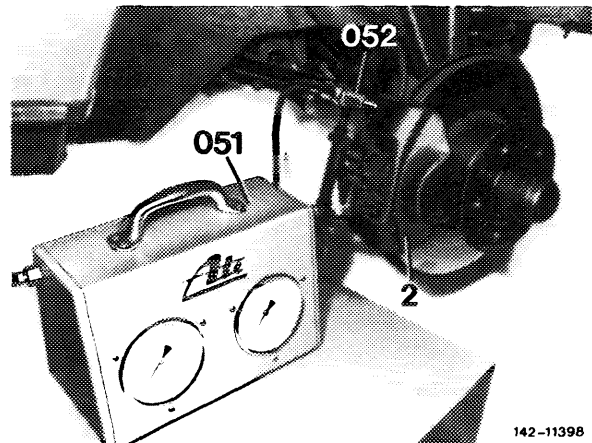

If only a slightly reduced vacuum is attained or if the vacuum drops off immediately, the reason may be as follows:

- a) Leaking vacuum line or leaking connections.
- b) Check valve is not operating correctly.
- c) Damaged O-ring between brake booster and tandem main cylinder.

- d) Damaged vacuum sleeve in tandem main cylinder; as a result, air may flow from atmosphere through leak bore of main cylinder into brake booster.
- e) Damaged sealing ring on control housing of brake booster. The sealing ring cannot be renewed with workshop equipment and must be replaced.
- f) Damaged vacuum pump.

6 If the available vacuum amounts to 0.75–0.8 bar, measure respective line pressure with specified force at brake pedal.

Note: If the line pressures measured deviate by more than ± 10 bar gauge pressure, replace brake booster.

7 Remove pedal force meter and test instruments.

8 Bleed brake system at caliper only to which the pressure tester was connected (42–010).