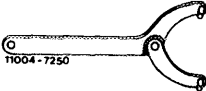
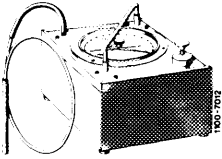
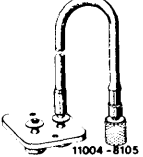

Model 123.1

Tightening torques	Nm
Slotted screw for pump cover	5
Slotted screw for closing cover	2.5
Hex. socket screw in diaphragm rod	9

Special tools

Special wrench		000 589 00 05 00
Vacuum tester		116 589 25 21 00
Assembly cover for vacuum pump		617 589 03 63 00

Note

On this vacuum pump only the two diaphragms, the four plate valves and the check valve can be replaced. This requires the two repair kits 000 586 12 43 (valves) and 000 586 13 43 (diaphragms). Any reconditioning of other parts with workshop equipment is not possible. In such a case, the pump must be completely replaced.

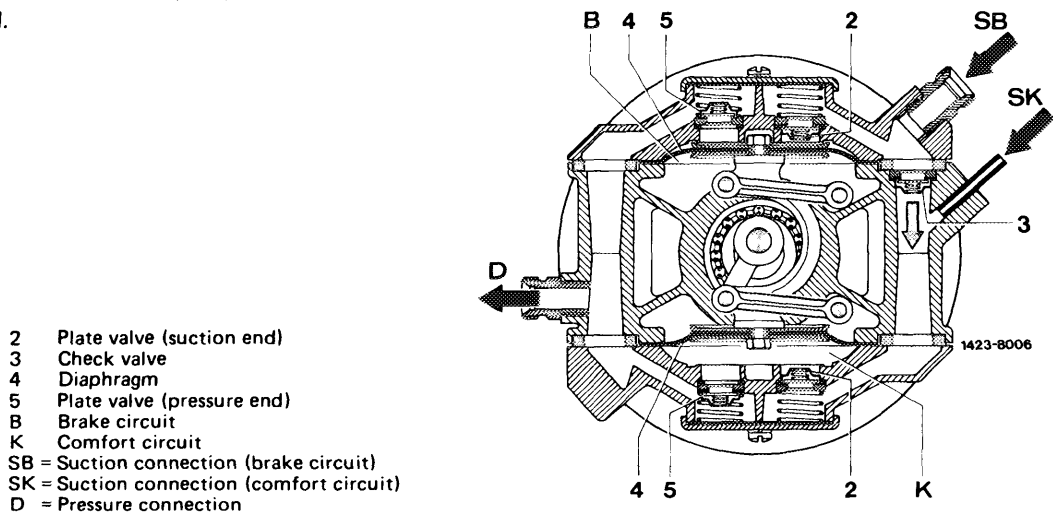

## Disassembly

---

- 1 Clamp vacuum pump into a vise using aluminum jaws.
- 2 Unscrew slotted screws from closing cover (6) and remove cover.

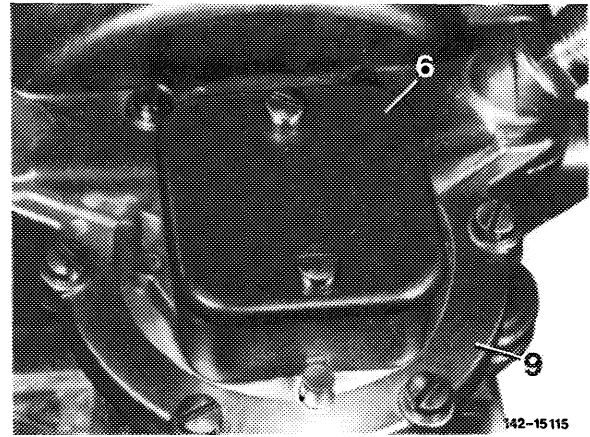

- 3 Remove both compression springs (32), plate valves (2 and 5) and the two sealing rings. Unscrew slotted screws from pump cover (9) and remove pump cover. Clean pump cover.

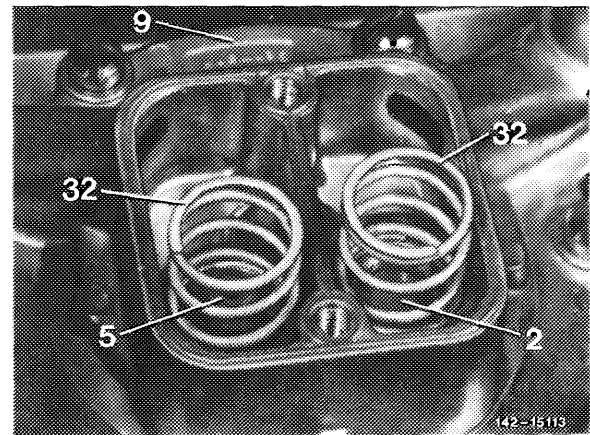

- 4 Unscrew hex. screw (3) from diaphragm rod and remove diaphragm (4) with both diaphragm discs (10b). Also remove sealing rings (24).

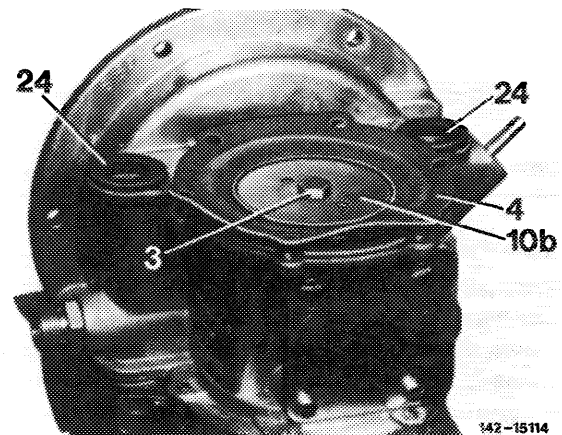

## Assembly

---

- 5 Make female threads in diaphragm rod (26) free of grease, replace O-ring (27).

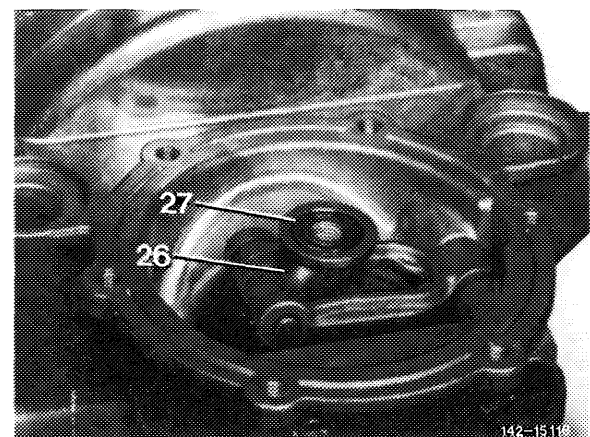

6 Place lower diaphragm disc (10a) with beaded edge in downward direction, then diaphragm with lettered or raised part in upward direction and upper diaphragm disc with beaded edge in upward direction on diaphragm rod.

**Attention!**

Install grey-green diaphragms from repair kit only. Simultaneously, use the new diaphragm discs, since the removed diaphragm discs are permanently distorted.

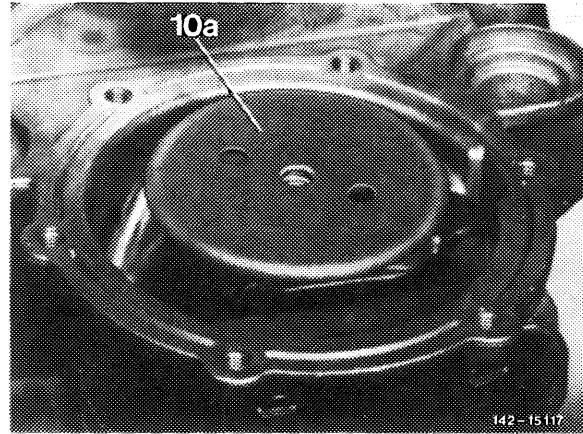

7 Coat threads of hex. screw with Loctite, screw into diaphragm rod and tighten to 9 Nm, while applying counterhold to diaphragm disc (10b) with special wrench (051), making sure that diaphragm (4) with flattened side faces motor screw-on flange.

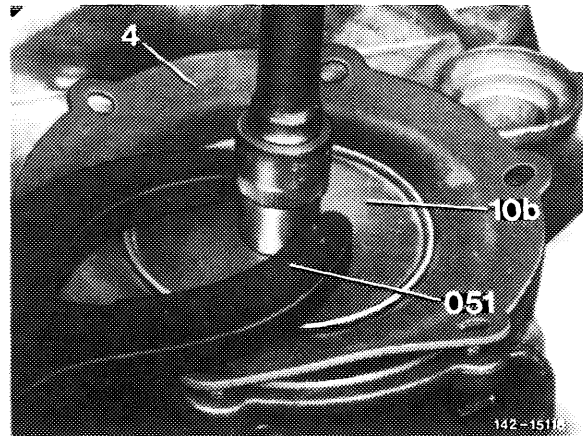

**Note:** When renewing diaphragm in system circuit B, simultaneously change check valve (30).

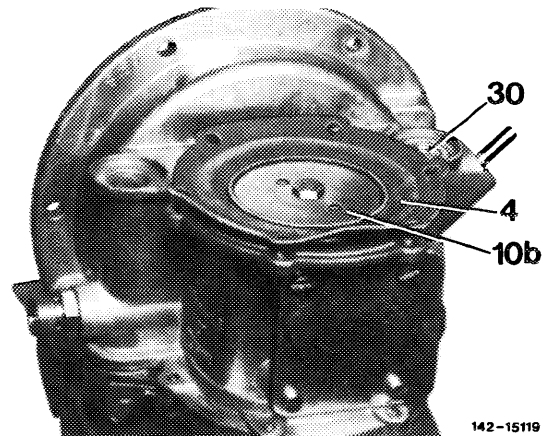

8 Upon installation of check valve (30), place new sealing rings (24) into pump housing.

**Note:** To prevent damage to diaphragm, mount diaphragm under a slight preload. Use assembly cover for vacuum pump for this purpose.

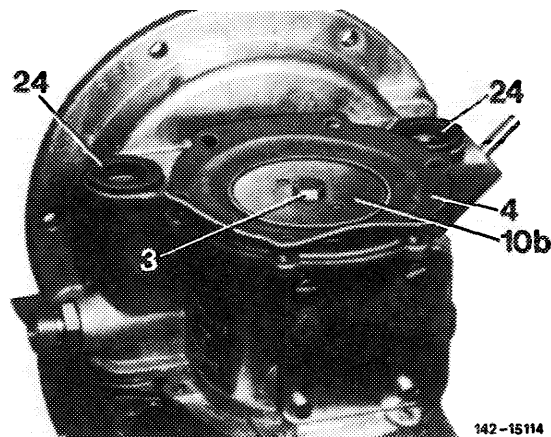

9 Place pump cover (9) on housing (8). Screw-in slotted screws of pump cover for 2–3 threads. Place sealing rings for valves into valve housing.

10 Attach assembly cover (035) to pump cover (9). Then connect vacuum hose to tester (030).

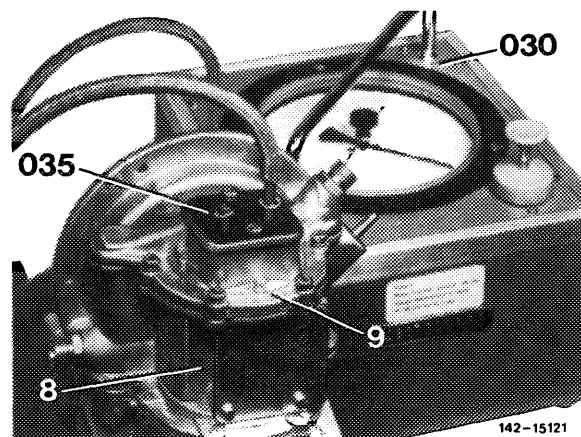

11 Push pump cover (9) against housing (8) at spots designated by arrows. Use hand pump in tester (030) to establish a vacuum of min. 0.5 bar. If vacuum remains constant without actuating hand pump, tighten slotted screws in pump cover to specified torque of 5 Nm.

**Note:** Other suitable units may also be used to attain the required vacuum.

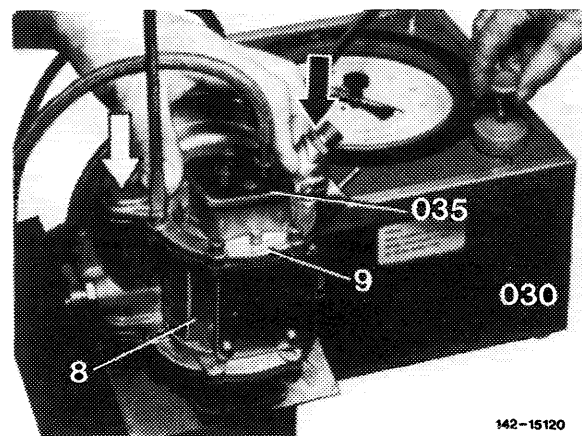

12 Remove assembly cover from pump cover.

13 Place plate valves (2 and 5) into valve seats as follows:

Layout of plate valves in system circuit B. Cover with screw connection.

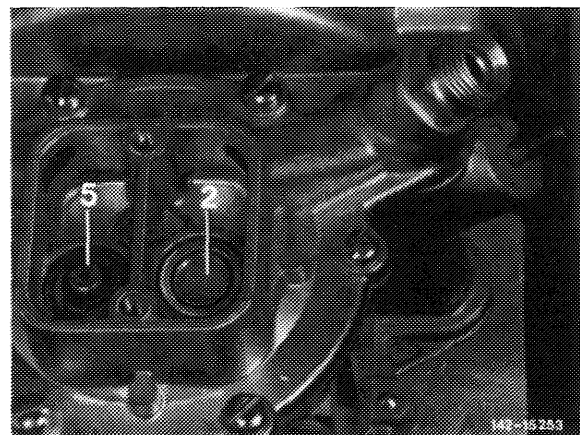

Layout of plate valves in system circuit K. Cover without screw connection.

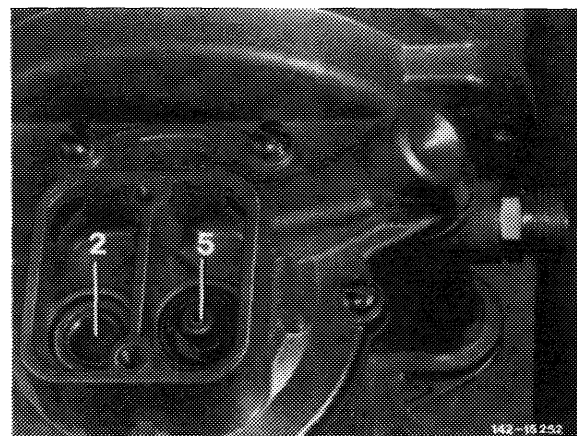

14 Insert compression springs (32) and attach closing cover to pump cover using a new gasket.

