

Model 123.1

Tightening torques

Nm

Slotted screws for pump cover

2.5

Self-locking hex. nut on piston rod

9

Special tool

Assembly plate for piston rod



115 589 14 21 00

- 2 Plate valves (suction end)
- 3 Self-locking hex. nut
- 4 Piston
- 5 Plate valve (pressure end)
- 7 Gasket
- 8 Pump housing
- 9 Pump cover
- 10 Piston disc
- 14 Outer compression spring
- 15 Lower spring retainer
- 16 Roller
- 17 Piston rod
- 18 Washer
- 20 Sealing ring
- 21 Inner compression spring
- 23 Upper spring retainer
- 28 Piston ring
- 29 O-ring

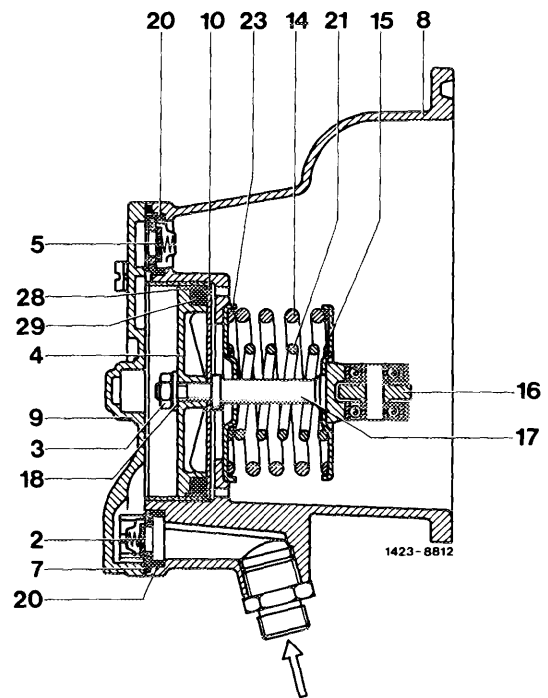

Note

Reconditioning of vacuum pump requires repair kit part no. 000 586 17 23.

Disassembly

- 1 Turn screw of assembly plate completely back.
- 2 Insert vacuum pump into assembly plate (050) in such a manner that seam of casting (refer to arrow) points accurately into center between the two hex. socket screws (25) of plate.
- 3 Push piston rod including piston to TDC by screwing spindle up to stop.

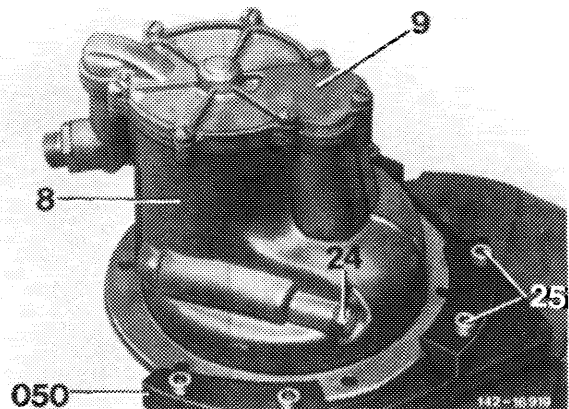

4 Unscrew slotted screws from pump housing and remove pump cover (9).

5 Remove gasket (7) for pump cover as well as gaskets and plate valves (2 and 5) from pump housing (8).

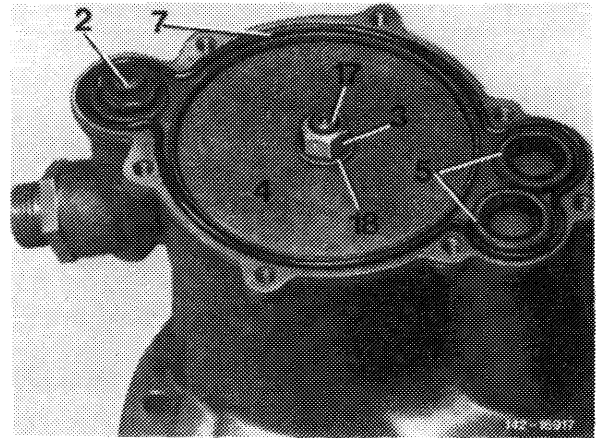

6 Unscrew self-locking hex. nut (3) from piston rod (17). Remove washer (18).

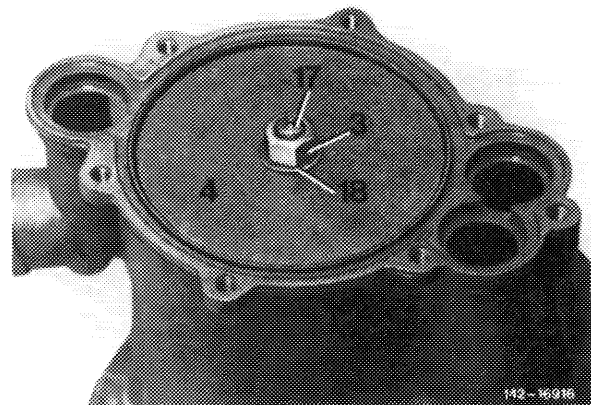

7 Screw spindle of assembly plate completely back. Then pull piston (4) out of pump housing (8) with suitable circlip pliers.

8 Remove piston disc from pump housing (8).

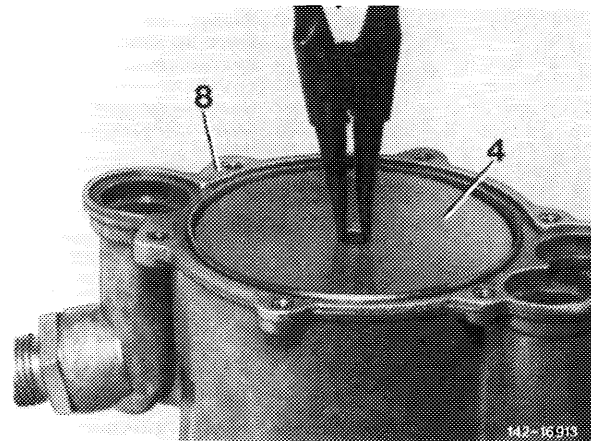

9 Remove piston ring (28) and O-ring (29) from piston (4).

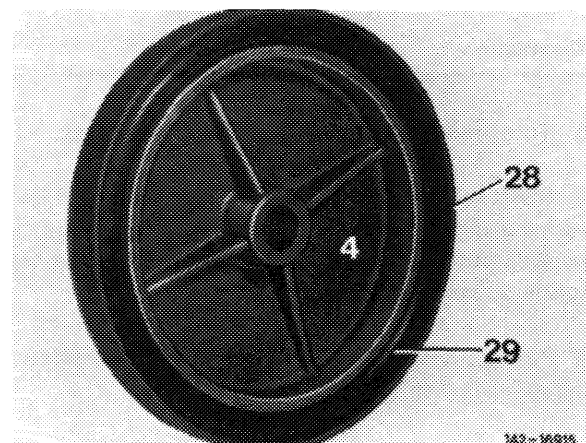

Assembly

Note: Prior to assembly, check piston liner and roller for wear. In the event of a worn liner or score marks, replace vacuum pump. If roller, ball bearing, piston rod, rocker arm and arm shaft are showing signs of wear, recondition vacuum pump with repair kit part no. 000 586 18 23 (42-635).

Check sealing surface on pump cover for gasket. Cover should be flat and level.

10 Clean piston (4). Mount new O-ring (29) and piston ring (28). For this purpose, lubricate parts slightly.

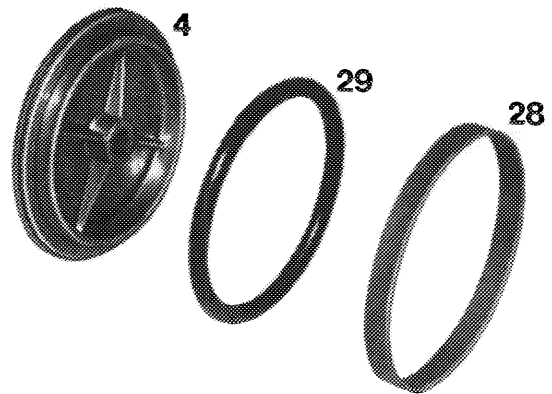

142-10921

11 Push piston rod (17) up to stop in upward direction by means of screw spindle of assembly plate. Make sure that flange of piston rod is guided perfectly through upper spring retainer (23).

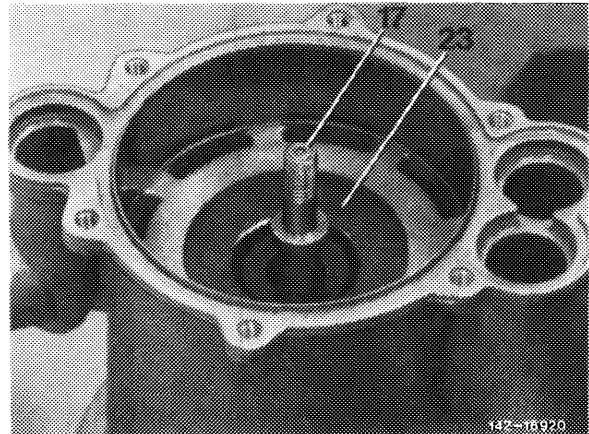

142-10920

12 Place piston disc (10) on piston rod (17) with the 4 dead centers ahead.

13 Slightly lubricate piston liner.

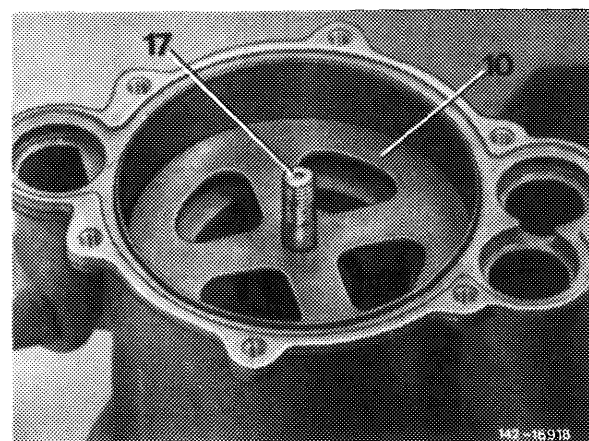

142-10918

14 Mount piston (4), making sure that the piston ring is not damaged.

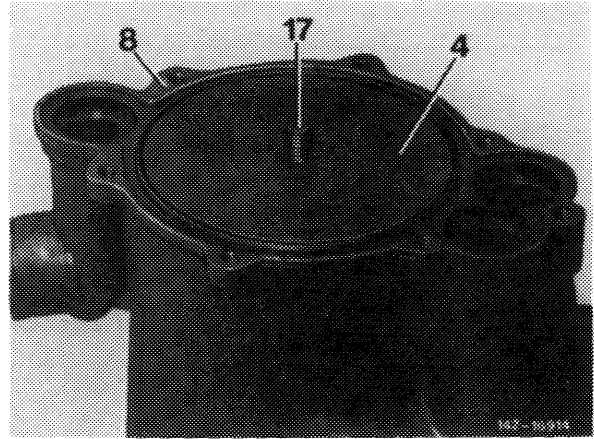

15 Mount washer (18). Then lightly screw-on self-locking hex. nut (3) and move piston (4) against housing bottom by turning-back screw spindle. Then tighten hex. nut (3) to 9 Nm.

Note: Self-locking hex. nut may be used only once.

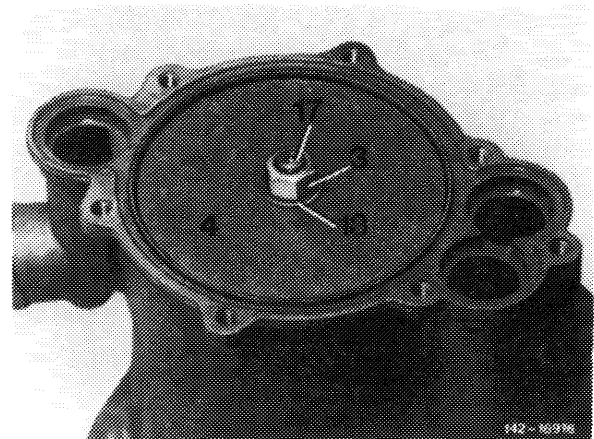

16 Insert sealing ring (7), new sealing rings and the three plate valves (2 and 5) in correct installation position into pump housing.

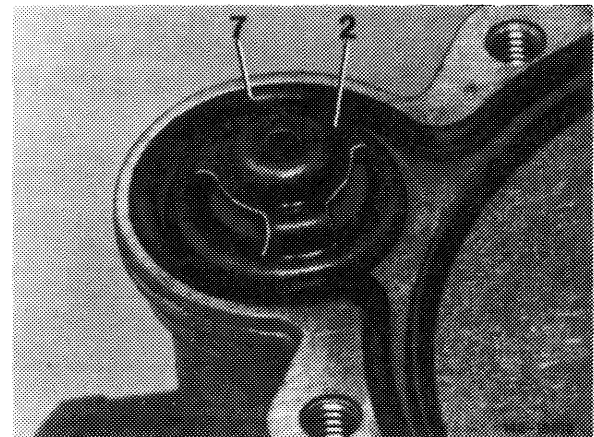

Layout suction end

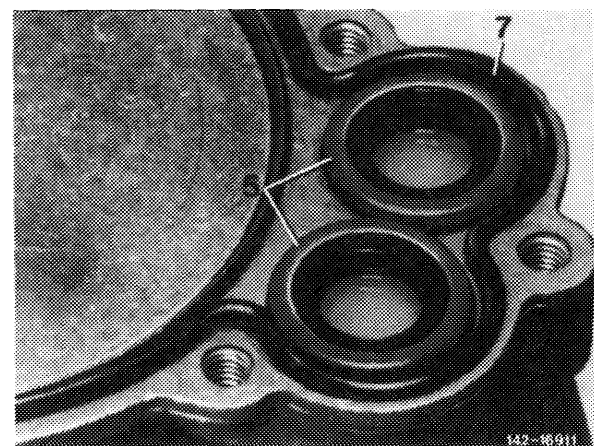

Layout pressure end

17 Place pump cover (9) on housing. Screw-in slotted screws and tighten to 2.5 Nm.

18 Remove pump from assembly plate.

