

46–520 Removal and installation of intermediate steering arm

Data



Part number	Version	Code number	Remark
123 463 26 10	LL*	2326	1st version for manual and power steering (with stop lug)
123 463 27 10	RL	2327	
123 463 32 10	LL	2332	2nd version for manual steering (with stop lug) modified ball point location and replacement for 123 463 26 10 and 123 463 27 10
123 463 33 10	RL	2333	3rd version for power steering, replacement for 123 463 28 10/29 10 and 123 463 30 10/31 10
123 463 28 10	LL	2328	Intermediate version for power steering (without stop lug, mount without washer)
123 463 29 10	RL	2329	
123 463 30 10	LL	2330	2nd version for power steering (without stop lug, changed ball point position)
123 463 31 10	RL	2331	

*LL = lefthand steering
RL = righthand steering

Adjusting value

Permissible difference in height of ball point position between pitman arm and intermediate steering arm	4 mm
Tightening torques	Nm
Self-locking hex nut for attaching intermediate steering arm	120
Castle nut or self-locking hex. nut on track rod and drag link	35

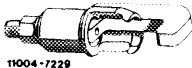
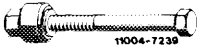
Special tools

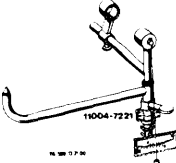
Puller for ball joint of track rod to intermediate steering arm		186 589 10 33 00
Puller for ball joint of drag link to intermediate steering arm		123 589 09 33 00
Puller for rubber slide bearing		116 589 01 33 00
Installation tool for rubber slide bearing		115 589 08 61 00
Measuring tool for control arm and ball point position		123 589 03 21 00

Removal

1 Unscrew castle nut of drag link and track rod. Unscrew castle nut or self-locking hex. nut.

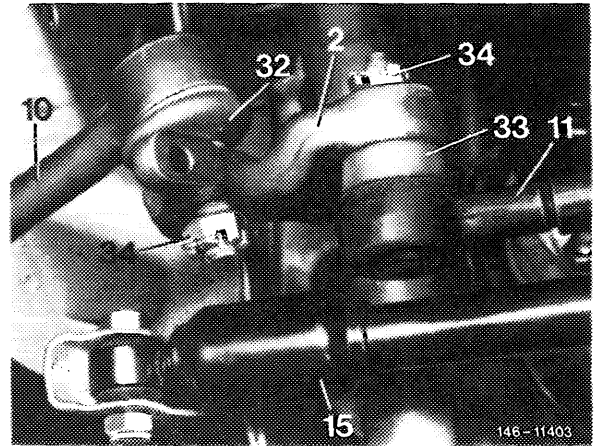

2 Force ball joint of track rod (10) from intermediate steering arm with puller (026).

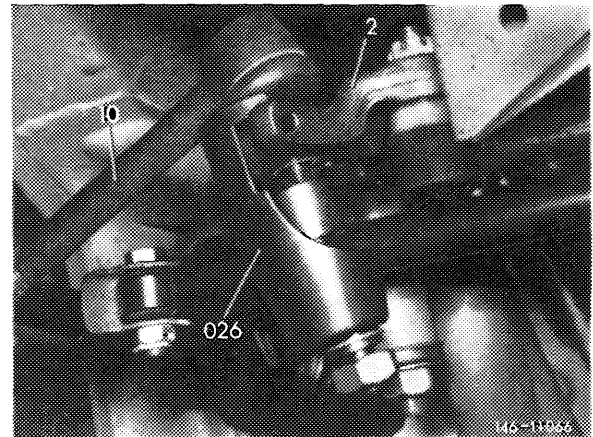

3 Force ball joint of drag link (11) from intermediate steering arm (2) by means of puller (020). On 1st version of drag link, pay attention to plastic cover and sealing ring.

Note: To prevent damaging rubber sleeve on drag link 2nd version, force-off drag link with modified puller 123 589 09 33 00 only.

Use puller 123 589 00 33 00 only, if the puller bell has been refinished.

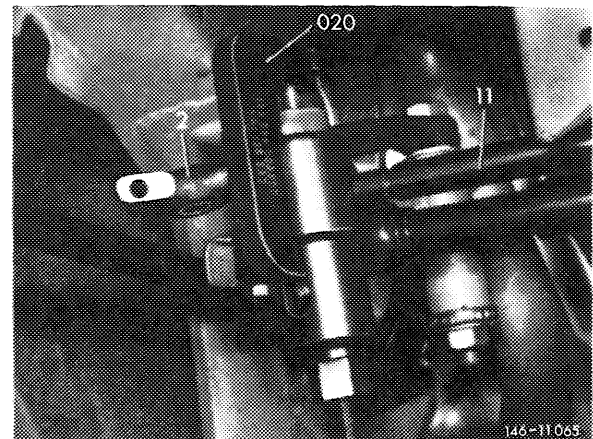

4 Unscrew self-locking hex nut (9) from hex nut (1), remove sealing washer (4).

5 Remove hex bolt (1) together with intermediate steering arm (2) and dust cap (8). Watch out for washer (3), if any, inserted between intermediate steering arm and dust cap.

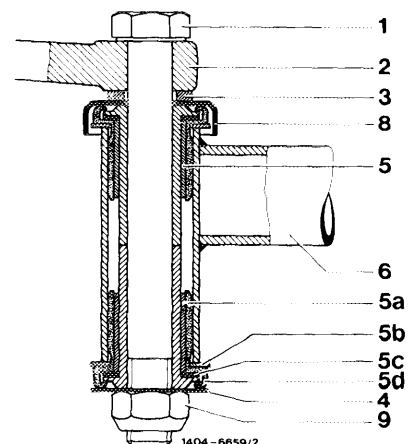

Checking and reconditioning

6 The intermediate steering arm cannot be checked with conventional workshop equipment. **When in doubt**, particularly following an accident, **replace intermediate steering arm**.

Pay attention to correct code number (arrow) of intermediate steering arm.

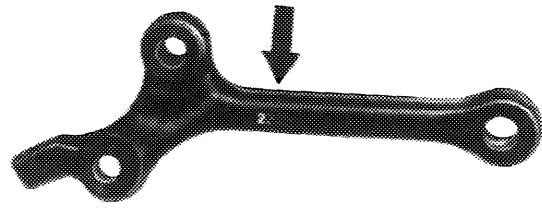

146 - 11 420

Note:

a) Intermediate steering arm 1st version (with stop lug) for mechanical and power steering (code number 2326 LL (lefthand steering) or 2327 RL (righthand steering)).

Ball point location = $117 \begin{matrix} +4.5 \\ -2.5 \end{matrix}$

b) Intermediate steering arm 2nd version (with stop lug) for mechanical steering (code number 2332 LL (lefthand steering) or 2333 RL (righthand steering)).

Ball point location = $121 \begin{matrix} +4.5 \\ -2.5 \end{matrix}$

This arm simultaneously replaces the 1st version. If the intermediate steering arm 2nd version is installed instead of the 1st version, always add washer part no. 115 463 00 52 between arm and dust cap.

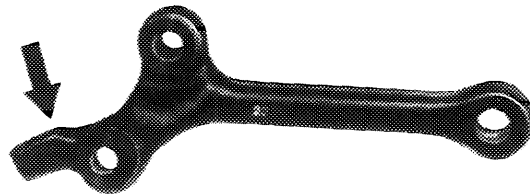

146 - 11 420/1

c) Intermediate steering arm 2nd version (without stop lug) for power steering with inside stop (code No. 2330 lefthand steering or 2331 righthand steering).

Ball point position = $121 \begin{matrix} +4.5 \\ -2.5 \end{matrix}$

Install this intermediate steering arm only if the steering is identified with an "A" = lock in steering housing.

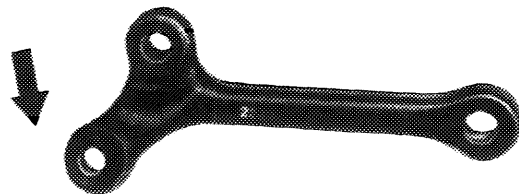

146 - 11 420/2

d) Intermediate steering arm 3rd version (with stop lug) for power steering with inside stop (code No. 2332 lefthand steering or 2333 righthand steering).

Ball point position = $121 \begin{matrix} +4.5 \\ -2.5 \end{matrix}$

This arm replaces intermediate steering arm 2nd version (code No. 2330 lefthand steering or 2331 righthand steering) and the intermediate version (code No. 2328 lefthand steering or 2329 righthand steering).

e) Intermediate steering arm intermediate version (without stop lug) for power steering with inside stop code No. 2328 lefthand steering or 2329 righthand steering).

The specified ball point position of $121 \begin{matrix} +4.5 \\ -2.5 \end{matrix}$

is attained, when washer (3) is not mounted. Install intermediate steering arm only on steering identified with an "A".

This intermediate steering arm is not available as a spare part.

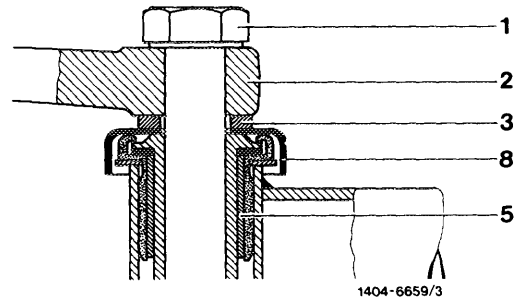

7 Check rubber slide bearing in journal bearing (6) for wear and renew, if required.

For this purpose, lift sealing lip of rubber bushing (5 d) with a screw driver.

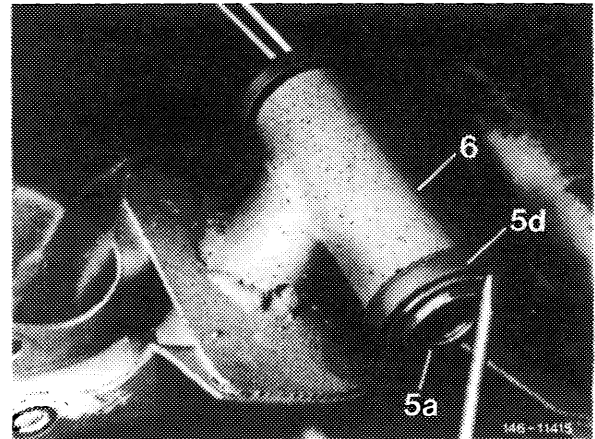

8 Remove slide bushing (5 a) from rubber mount.

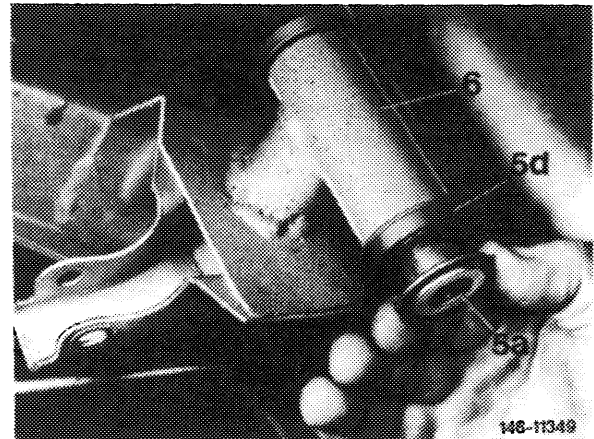

9 Remove both rubber bushings (5 d) from journal bearing with puller (061).

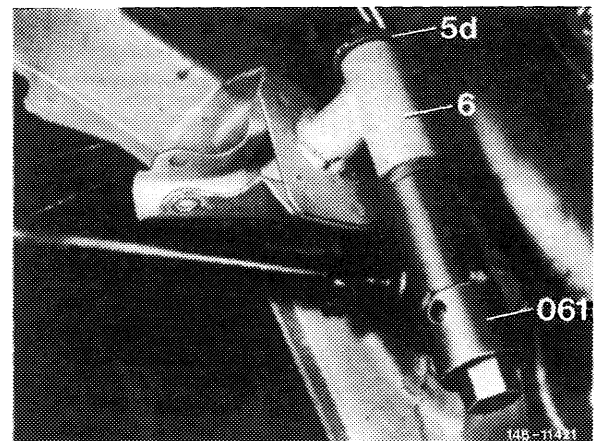

Installation

Note: a) Install rubber slide bearings with longitudinal grooves only.

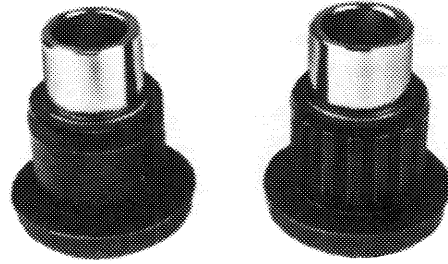

at left: smooth rubber slide bearing
at right: rubber slide bearing with longitudinal grooves

146-10143

b) In the event of complaints about noise, install steel washer, part no. 115 463 01 52 (15) between both slide bushings.

Note that the end play of slide bushings in both rubber bushings may amount to max. 0.5 mm. The end play is checked by pushing intermediate arm up and down.

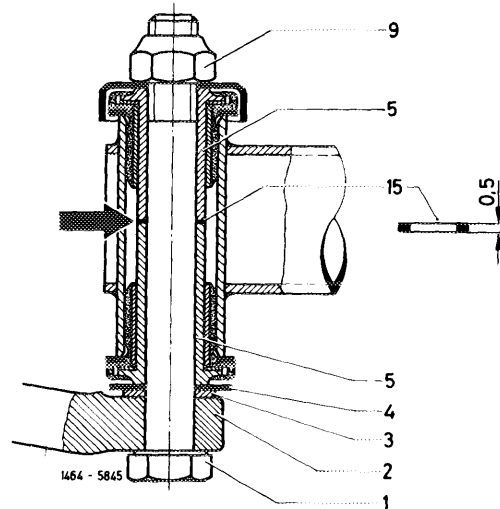

10 Coat rubber slide bearing (5) outside with slide fluid, e.g. with oil and press into journal bearing (6) with installation tool (062).

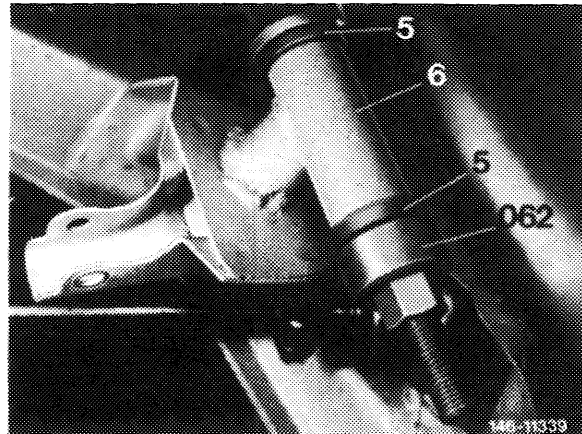

11 Place dust cap (8) on upper rubber slide bearing.

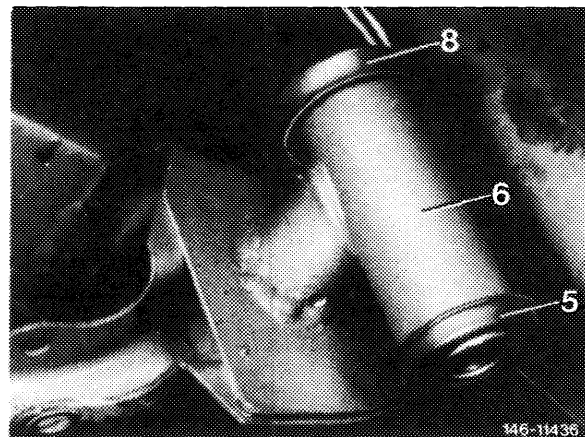

12 Insert hex bolt (1) with intermediate steering arm (2) and dust cap (8) into rubber slide bearings.

Note: Mount hex bolt with bolt head facing intermediate steering arm.

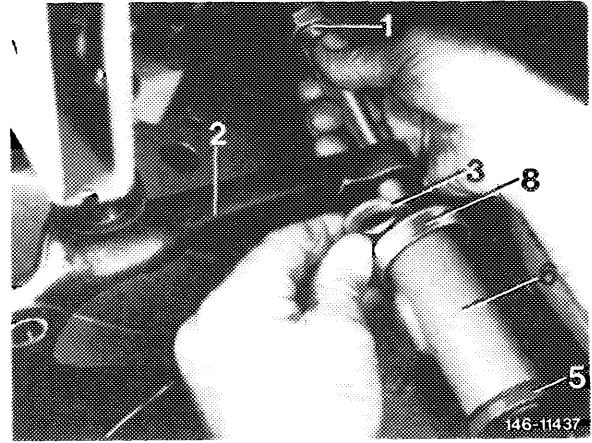

13 If washer (3) has been inserted between dust cap (8) and intermediate steering arm (2), put washer back again.

Note: The intermediate steering arm 123 463 2810 LL (lefthand steering) or 123 463 29 10 RL (righthand steering) (code number 2328 or 2329) are installed without washer (3).

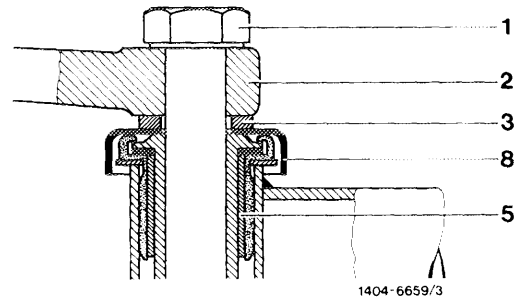

14 Mount sealing washer (4), screw-on normal hex nut (not self-locking) M 16 x 1.5 and tighten to approx. 70 Nm.

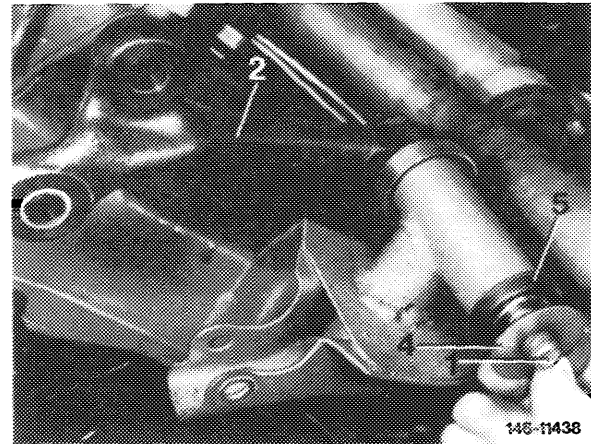

15 Measure permissible deviation in height of ball point location between pitman arm and intermediate arm. Max. permissible difference 4 mm. If the difference is larger, complete remedies (40–320).

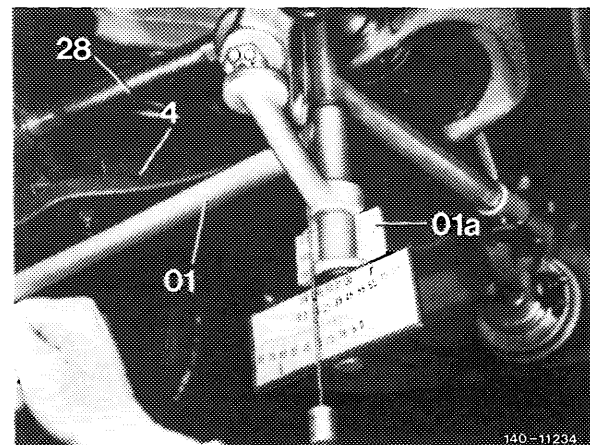

16 Unscrew hex. nut, then screw-on new self-locking hex. nut (9) and tighten to 120 Nm.

Note: Upon tightening of self-locking hex. nut, one thread of hex. screw should again project beyond hex. nut.

Attention!

Replace self-locking hex. nut on principle.

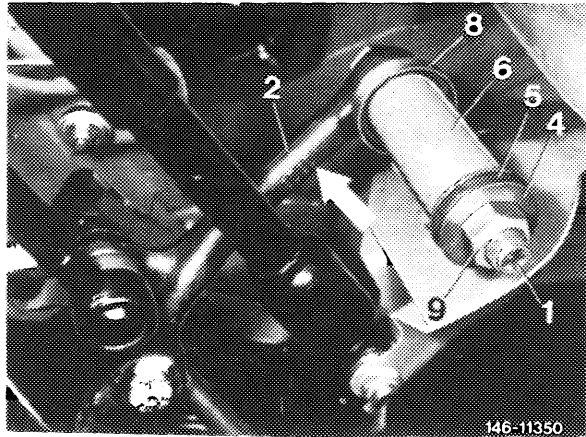

17 Check rubber sleeve (32) on joint of track rod. If sleeve is damaged, check joint for wear and replace, if required (46–540).

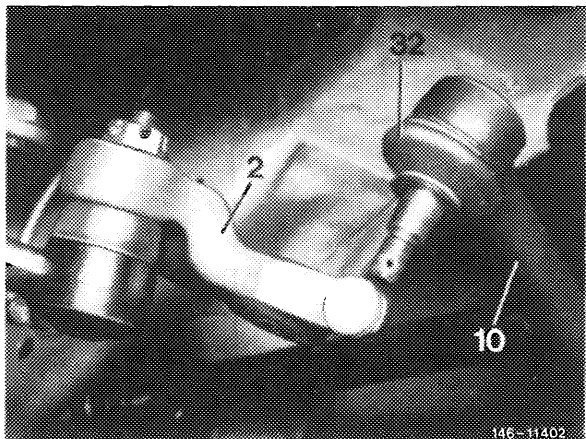

18 With drag link 1st version, check joint of drag link for wear and replace drag link, if required. Place sealing ring (35) and plastic cover (33) on ball joint (46–550).

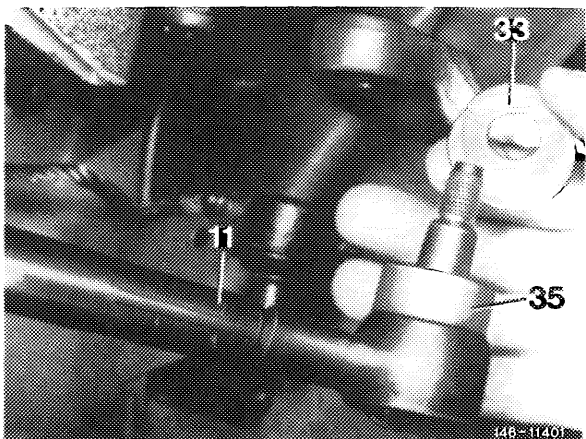

19 With drag link 2nd version, check rubber sleeve (32) on joint. If sleeve is damaged, check joint for wear and replace, if required (46–550).

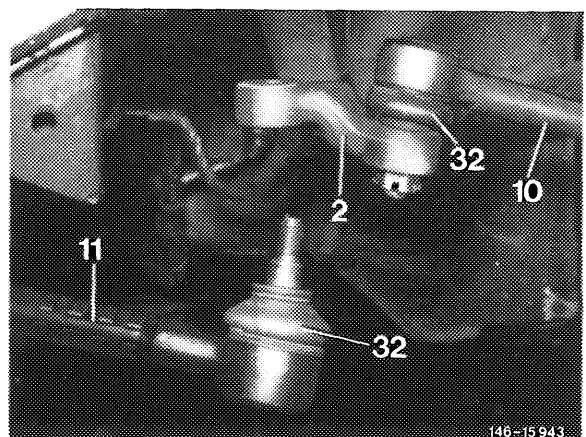

20 Fasten track rod and drag link to intermediate steering arm. Tightening torque 35 Nm – reference value.

Note: The track rod 1st and 2nd version is fastened to pitman arm by means of a castle nut and locked by a cotter pin. The 3rd version is fastened by means of a self-locking hex. nut.

The self-locking hex. nut must be replaced on principle.

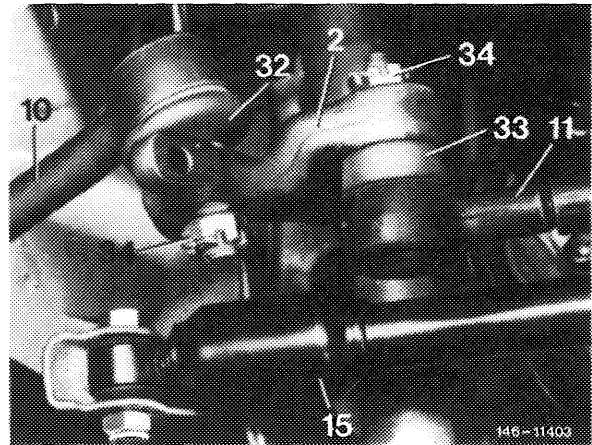

21 On vehicles with manual steering and power steering 1st version, check permissible steering lock while measuring reference dimension "a" between intermediate steering arm or pitman arm and stop bracket on frame cross member (40–320).

Note: At max. steering lock on vehicles with mechanical steering and power steering 1st version the respective arm should rest against stop bracket of frame cross member.

On vehicles with power steering 2nd and 3rd version the stop is in steering housing.

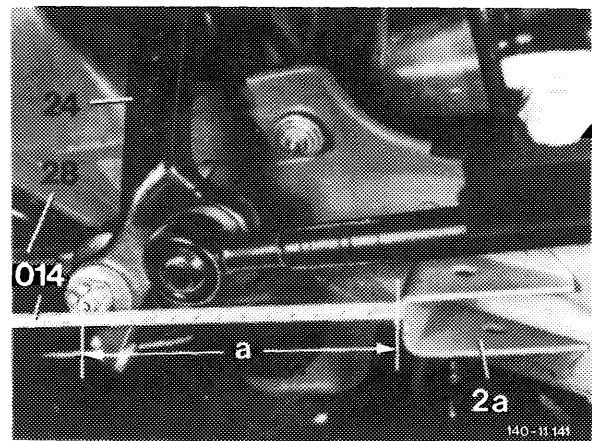

22 Check wheel adjustment on front axle. (40–320).