

46-625 Disassembly and assembly of jacket tube

Self-made tools

Thrust piece

refer to Fig., item 9 note

Assembly tool

refer to Fig., item 14 note

Disassembly

- 1 Remove jacket tube (46-620).
- 2 Loosen two slotted screws (49) on combination switch and remove cables of twin contact carbon from plug connection. Remove twin carbon.
- 3 Unscrew both Philips head screws (48) and remove combination switch.

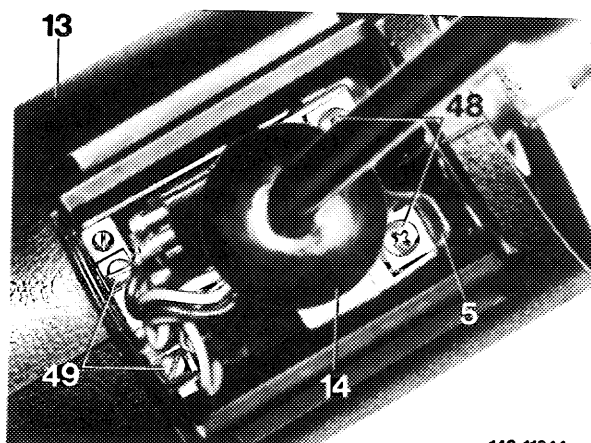

- 4 Screw both combination screws (47) out of jacket tube and remove jacket tube lining (13).

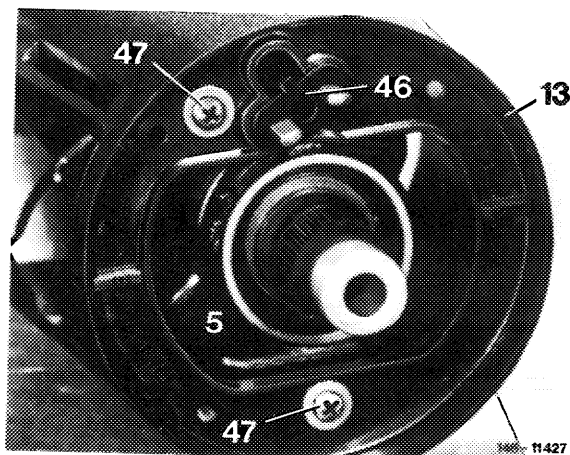

Jacket tube 1st version

- 5 Remove spacing ring (7) from steering shaft.

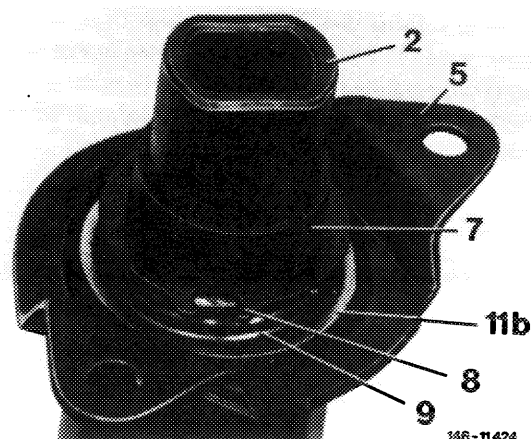

6 Remove grip ring (8) and then compression spring (9), supporting ring (10) and ball bearing (11) from steering shaft.

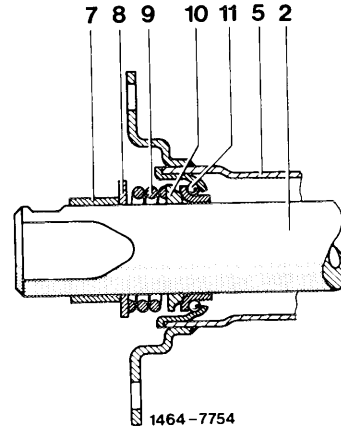

Jacket tube 2nd version

7 Remove grip ring (8), plate spring (15), supporting ring (16) and ball bearing (11) from steering shaft.

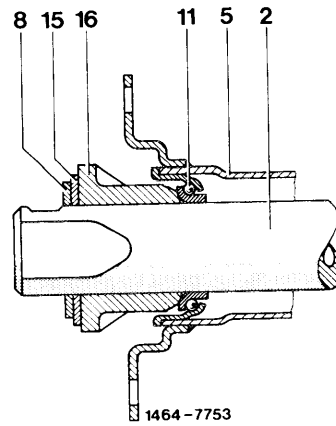

8 Remove locking ring (12), supporting ring (10) and ball bearing (11) from both versions.

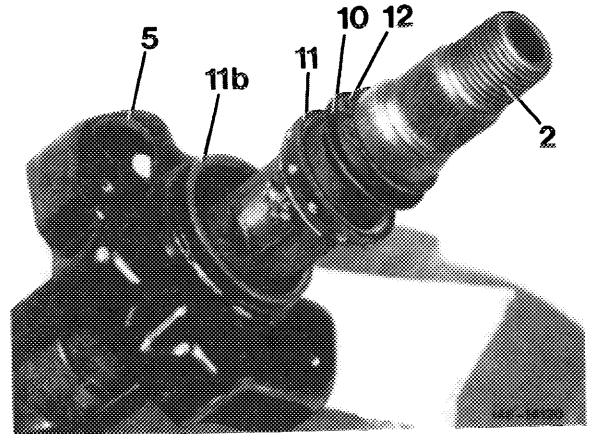

9 Insert thrust piece (050) into jacket tube and knock outer race (11 b) of upper ball bearing out of jacket tube with steering shaft. Then remove outer race of lower ball bearing out of jacket tube also using thrust piece.

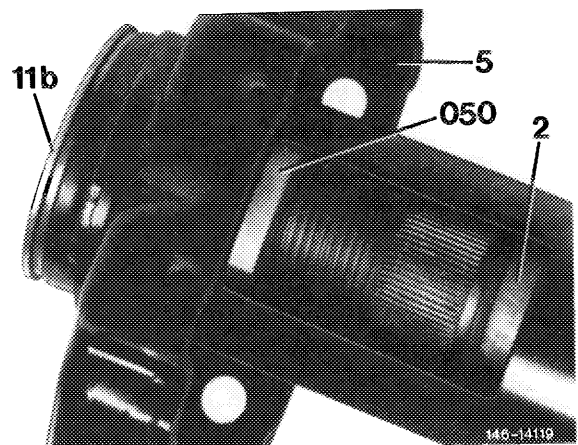

Note: The thrust piece is self-made according to specified dimensions.

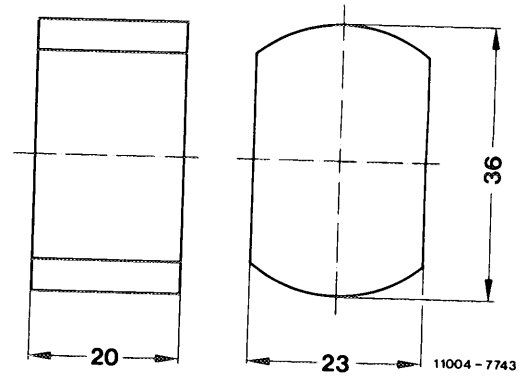

Installation

10 Prior to installation, check both ball bearings for wear and replace bearings, if required.

11 Press outer race (11 b) of upper ball bearing into jacket tube. Insert steering shaft into jacket tube and press-in lower outer race.

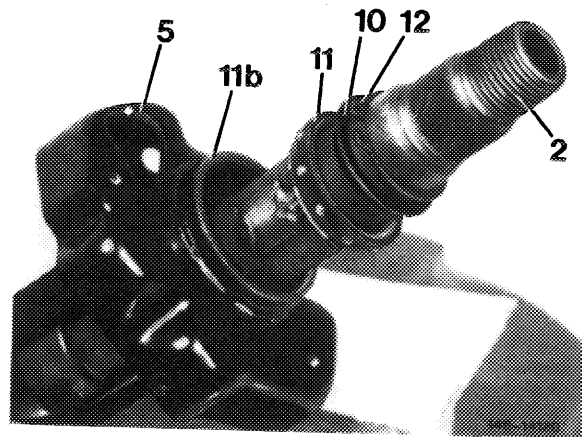

12 Place ball bearing (11) and supporting ring (10) on steering shaft, then insert locking ring (12).

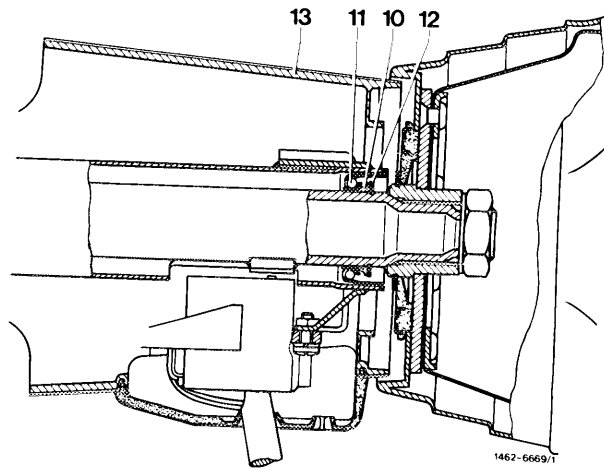

13 On jacket tube 1st version, place ball bearing (11), supporting ring (10) and compression spring (9) on steering shaft.

14 Position grip ring on steering shaft and force on steering shaft by means of assembly tool until compression spring is completely compressed.

Note: The assembly tool is self-made according to specified dimensions.

The guide piece welded into tube can be made from a steering shaft of models 114, 115 or 116.

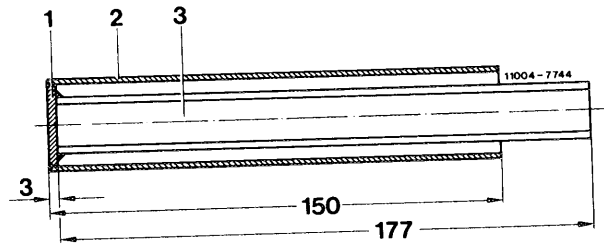

15 Slip spacing ring (7) on steering shaft.

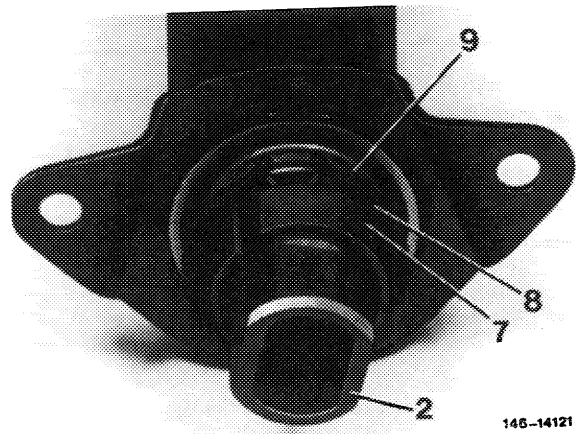

16 On jacket tube 2nd version, place ball bearing, supporting ring (16) and plate spring (15) on steering shaft.

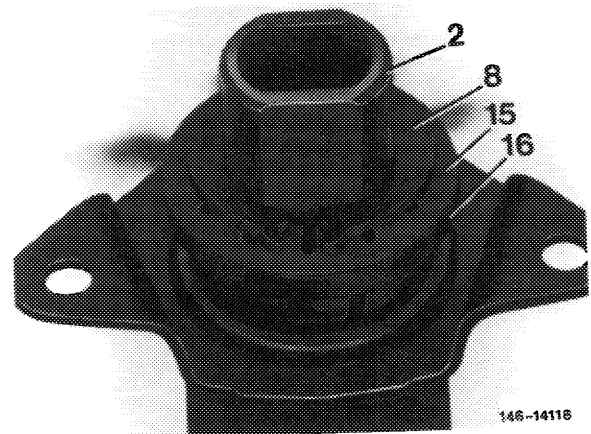

17 Position grip ring (8) on steering shaft and press on steering shaft by means of assembly tool until plate spring (15) is completely preloaded.

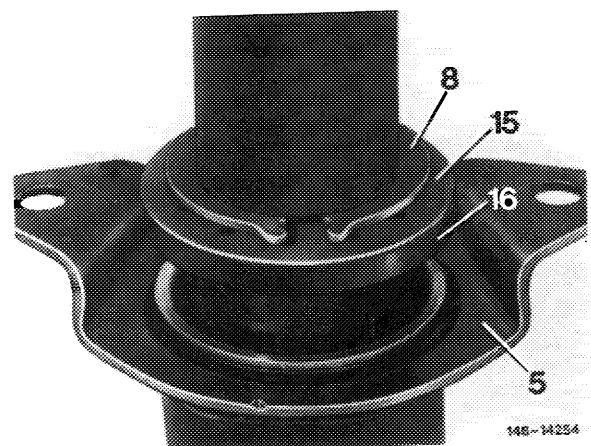

18 Attach jacket tube lining with two combination screws to jacket tube. Insert twin contact carbon.

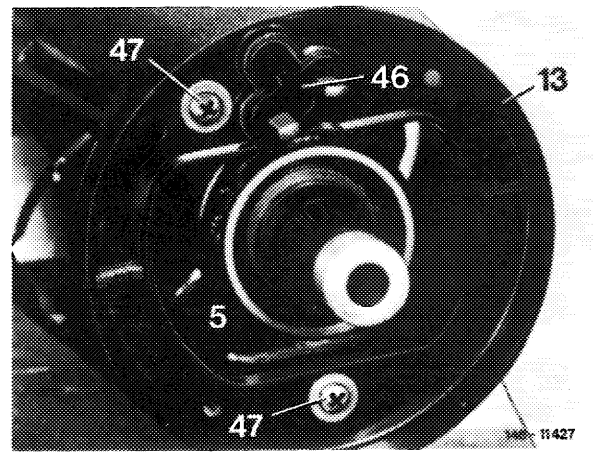

19 Insert combination switch into jacket tube. Prior to attaching combination switch, connect both cables of twin carbon. Knot cover for combination switch into lining.

