

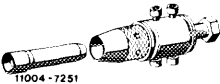



46-720 Disassembly, checkup and reconditioning of power steering pump

Special tools

Puller for radial sealing ring (basic unit)		116 589 24 33 00
Claw 33 mm dia. for VT 27 2nd version VT 49 and ZF pump		116 589 06 34 00
Claw 30 mm dia. for 1st version VT 49		116 589 05 34 00
Installation mandrel 33 mm dia. for VT 27 2nd version VT 49 and ZF pump		116 589 14 15 00
Installation mandrel 30 mm dia. for 1st version VT 49		116 589 13 15 00
Puller for pulley		108 589 02 33 00

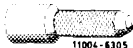
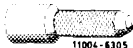
Self-made tools

Punch	refer to section B item 19, remark
Assembly sleeve	refer to section B and C item 10, remark

B. Vickers power steering pump VT 49 (grey iron and light alloy version)
 ZF power steering pump (light alloy version)

Disassembly

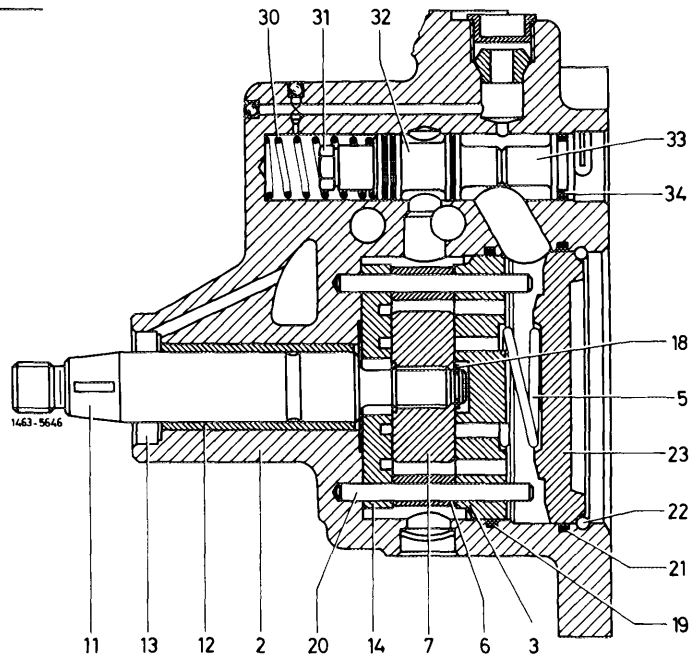

- 2 Pump housing
- 3 Pressure plate at cover end
- 5 Compression spring
- 6 Cam ring
- 7 Rotor with blade
- 11 Drive shaft
- 12 Bearing bushing
- 13 Radial sealing ring
- 14 Pressure plate at drive end
- 18 Locking ring
- 19 O-ring
- 20 Cyl. pin
- 21 O-ring
- 22 Circlip
- 23 Cover
- 30 Compression spring
- 31 Valve screw
- 32 Volume control valve
- 33 Closing plug
- 34 O-ring

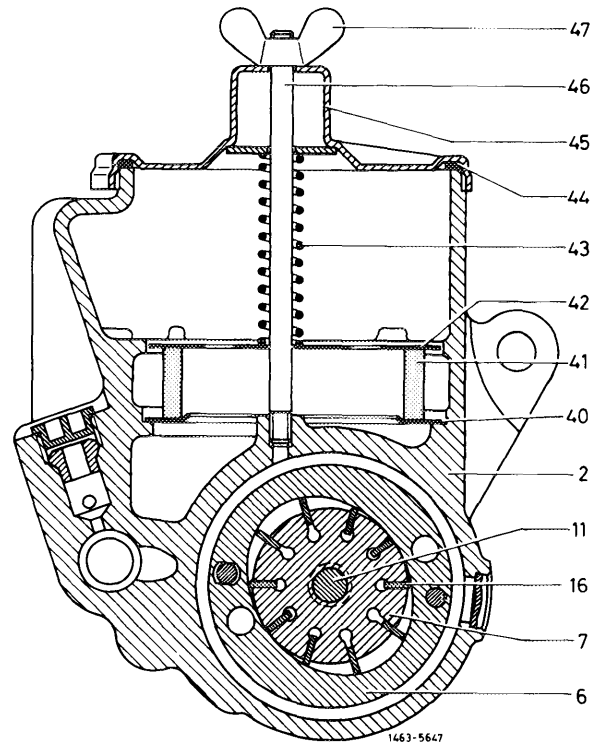

- 40 Steadying plate
- 41 Filter ring
- 42 Steadying plate
- 43 Compression spring
- 44 Gasket
- 45 Closing cover
- 46 Stud
- 47 Wing nut

1 Remove wing nut or knurled nut as well as closing cover.

2 On grey iron pump and on light alloy pump 2nd version, remove detent spring (58), compression spring (43) and upper steadying plate (42).

Note: On grey iron pump 1st version a washer is included between compression spring and closing cover, on second version this washer is attached to cover.

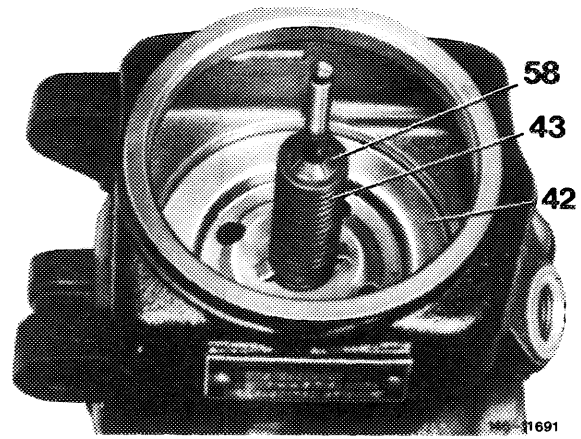

3 On grey iron pump and on light alloy pump 2nd version, remove filter ring (41) and lower steadying plate (40).

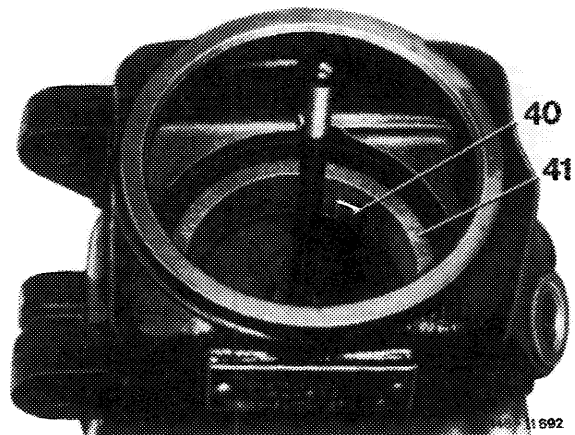

4 On light alloy pump 1st version, remove detent spring (58) from stud.

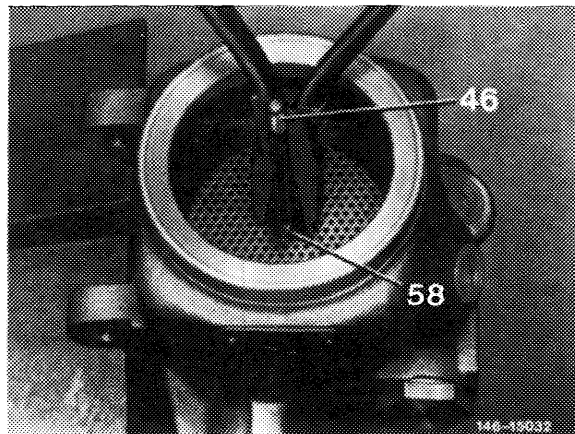

5 On light alloy pump 1st version, take steadying basket (60) out of pump housing.

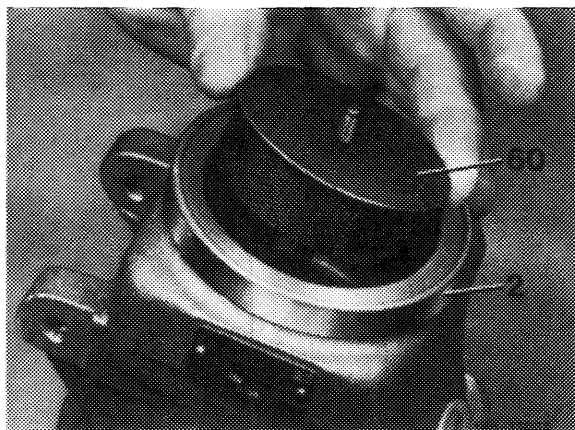

6 Remove Woodruff key from drive shaft.

7 Screw guide sleeve (050) on drive shaft.

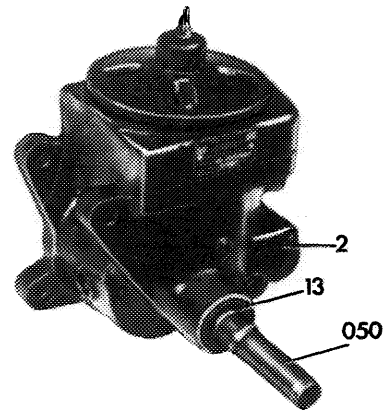

8 Turn hex. screw of puller (050) back and slip device on drive shaft, while punching through lips of radial sealing ring (13) by means of claws (052).

Note: Power steering pumps require the following claws for puller:

VT 49 1st version 30 mm dia.

VT 49 2nd version 33 mm dia.

Fasten respective claws to puller. The claw dia. is punched in.

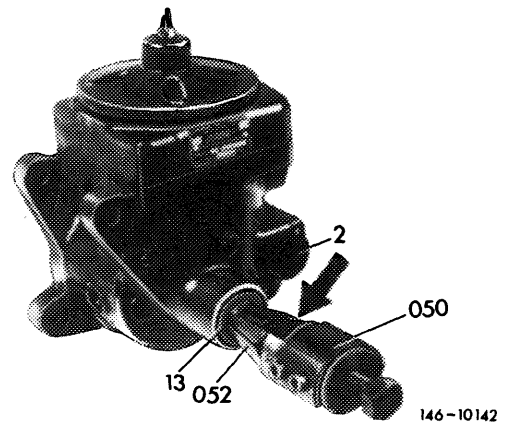

9 Turn clamping cone (arrow) of puller to the right up to stop, then pull sealing ring out of housing.

10 Place assembly sleeve (065) on power steering pump and push cover (23) slightly into housing by means of a hand press or a screw clamp.

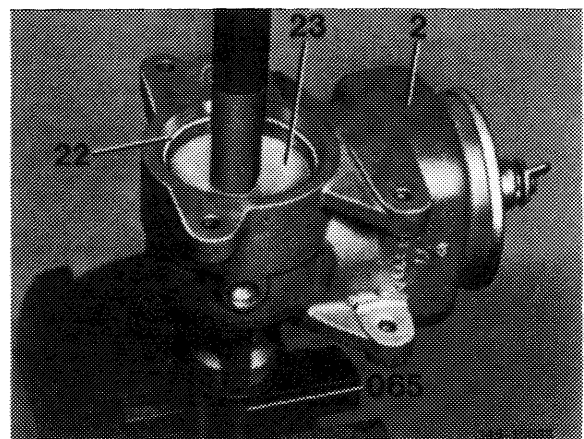

Note: The assembly sleeve is self-made according to specified dimensions.

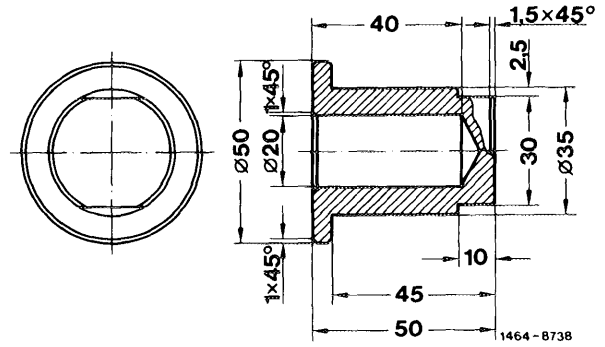

11 Remove circlip (22) from housing and take off cover.

Note: On grey iron pump the circlip can be pushed out of steering case through bore (2a) by means of a punch.

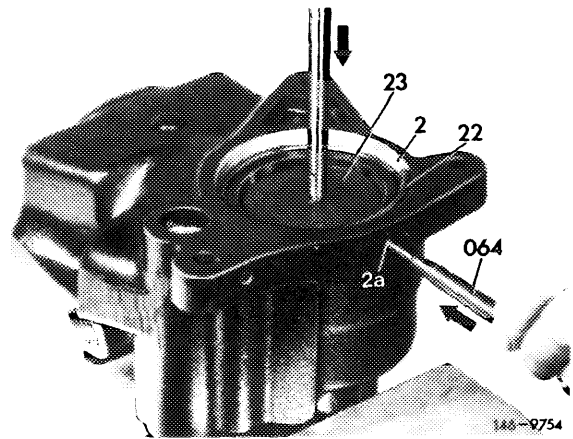

12 Remove spring (5) and O-ring (21) from pump housing (2).

13 Push drive shaft complete with pressure plate at cover end, rotor, cam ring and pressure plate at drive end toward the rear out of housing.

14 Remove pressure plate, cam ring and blade (10 each).

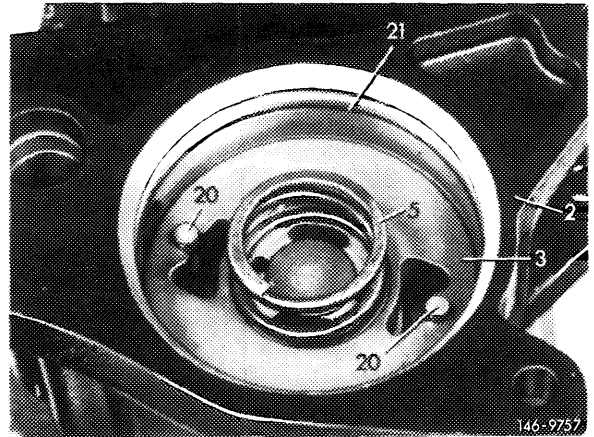

15 Remove locking ring (18) from drive shaft (11), then remove rotor (7) and pressure plate (14).

16 Take cyl. pins (20) out of pump housing.

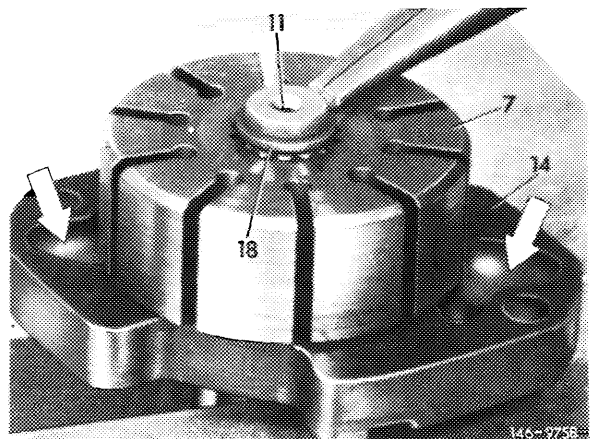

17 On grey iron power steering pump, knock locking pin (48) out of pump housing (2) with punch (064).

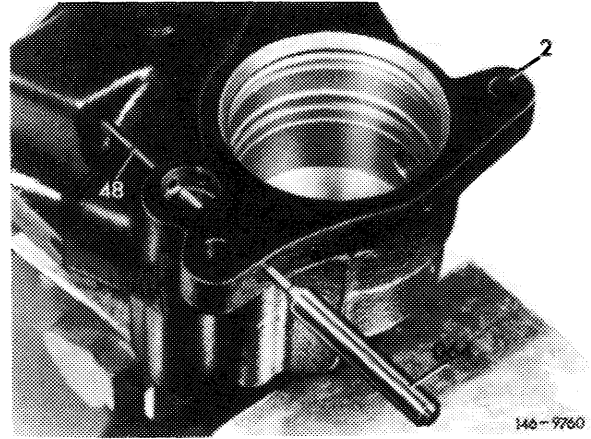

Note: The punch is self-made according to specified data.

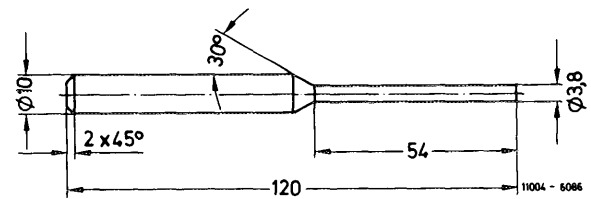

18 Remove closing plug (34), volume control valve (32) and compression spring (30) from housing.

Note: If closing plug remains seated in housing, loosen by means of light hammer blows against closing plug. **Make sure that the volume control valve is not damaged.**

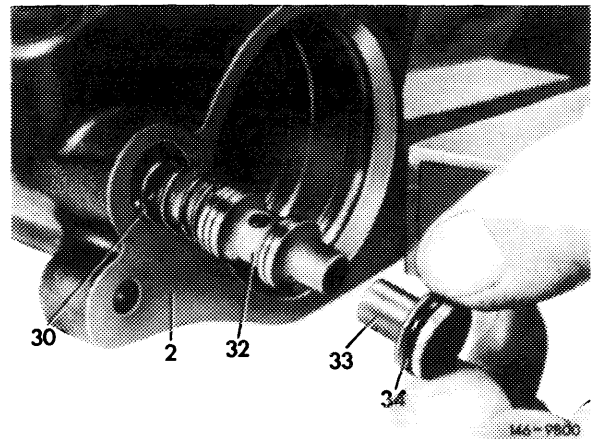

Light alloy power steering pump

- 2 Pump housing
- 3 Pressure plate at cover end
- 5 Compression spring
- 6 Cam ring
- 7 Rotor with blade
- 11 Drive shaft
- 12 Bearing bushing
- 13 Radial sealing ring
- 14 Pressure plate at drive end
- 18 Locking ring
- 19 O-ring
- 20 Cyl. pin
- 21 O-ring
- 22 Circlip
- 23 Cover
- 30 Compression spring
- 31 Valve screw
- 32 Volume control valve
- 34 Sealing ring
- 40 Lower steadying plate
- 41 Filter ring
- 42 Upper steadying plate
- 43 Compression spring
- 44 Gasket
- 45 Closing cover
- 46 Stud
- 58 Detent spring
- 59 Closing plug
- 60 Woodruff key

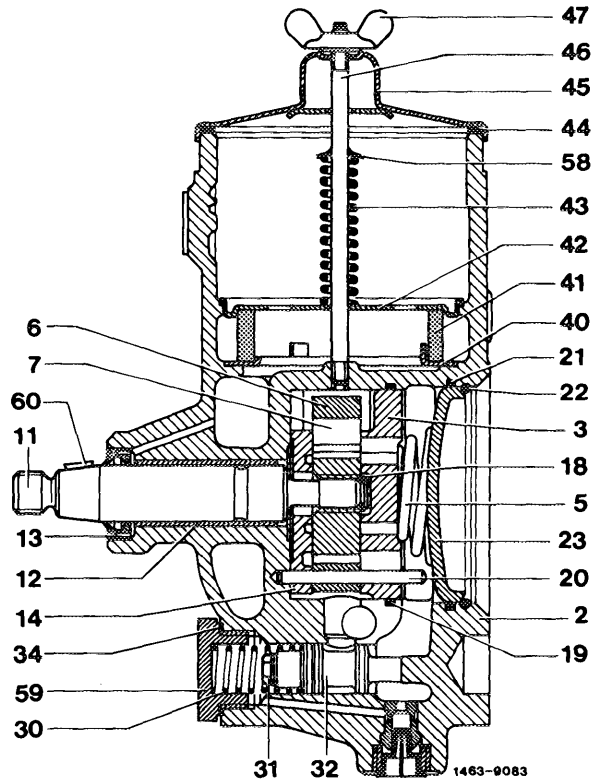

19 On light alloy power steering pump, unscrew closing plug (59) from housing, remove compression spring (30) and volume control valve.

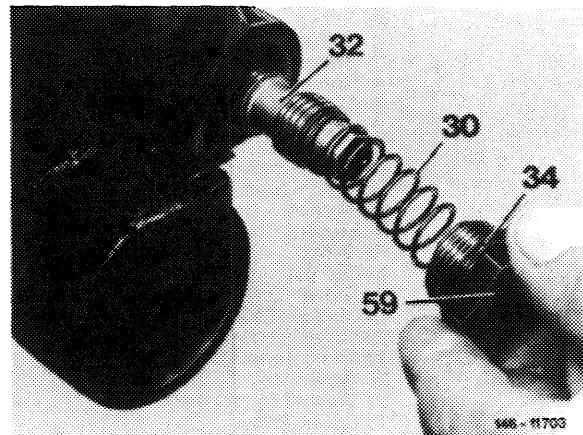

20 Clamp volume control valve (32) of both pump versions with its unground part into vise and unscrew valve screw (53) of pressure relief valve. Make sure that no spacing washer (52) is lost. Remove valve cone (51) and compression spring (50) from volume control valve.

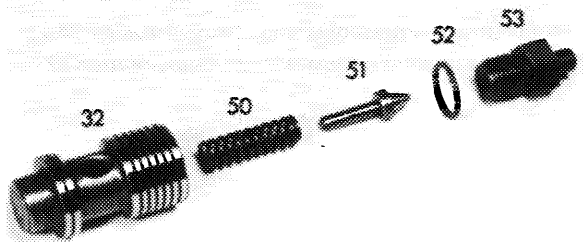

Checking and reconditioning

Repair sets

Designation	Power steering pump Vickers VT 49		ZF
	Grey iron	Light alloy	Light alloy
Set of seals	000 586 52 46		000 586 84 46
Pump insert	000 586 67 46		000 586 86 46
Drive shaft	000 586 53 46		000 586 85 46
Volume control valve	65 bar	000 586 70 46	000 586 87 46
	82 bar	000 586 69 46	000 586 88 46

21 Check ground surface of pressure plates (3 and 14).
With score marks on pressure plates, recondition power steering pump by means of repair set "pump insert".

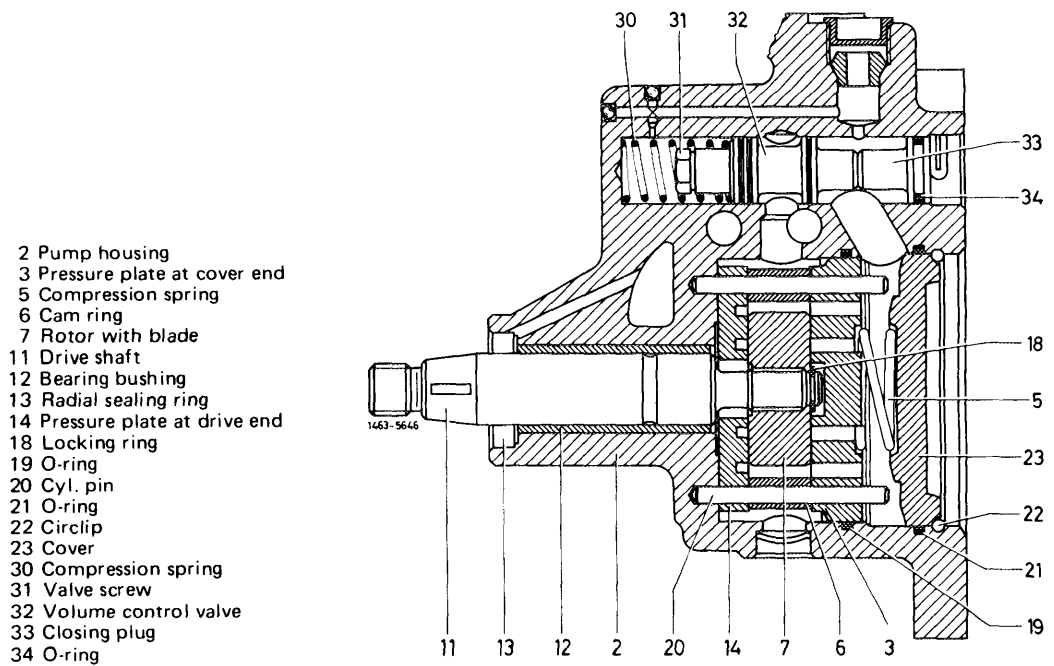

22 Check drive shaft (11) and bearing bushing (12) for wear. If required, install bushing from repair set "drive shaft".

Note: Install slotted bushing in such a manner that the slot is located opposite to pulling direction of V-belt.

23 Check blades in grooves of rotor (7), they should slide easily in rotor. Check slide surface of blades on cam ring (6) for wear. If required, recondition power steering pump by using repair set "pump insert".

Note: No noticeable marks should show up at slide surface of cam ring, since delivery capacity and smooth running of power steering pump depend on that surface.

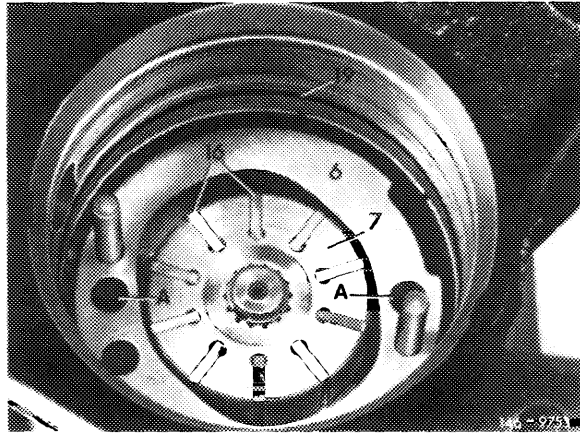

24 Check ground surfaces of volume control valve (32) and bore in pump housing for wear and damage. If the sliding surfaces are showing score marks, **renew complete power steering pump**. Never replace volume control valve only.

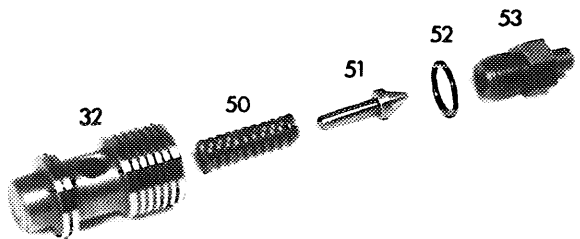

146-9989

25 Check both sealing cones (connection high-pressure expanding hose, return flow pipe). Replace distorted sealing cones. For this purpose, cut several 7 or 10 mm threads into sealing cone. Pull sealing cone out of housing by means of a 7 or 10 mm screw.

26 Position new sealing cones (48) in housing and push in by screwing high-pressure expanding hose or return flow pipe into housing.

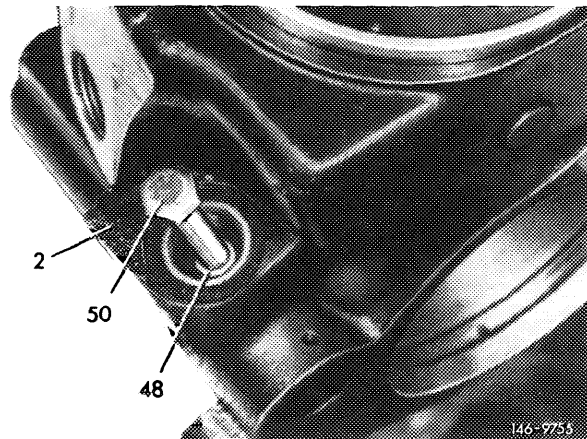

146-9755

C. ZF power steering pump (grey iron version)

Disassembly

- 1 Remove Woodruff key from drive shaft.
- 2 Screw guide sleeve (050) on drive shaft.

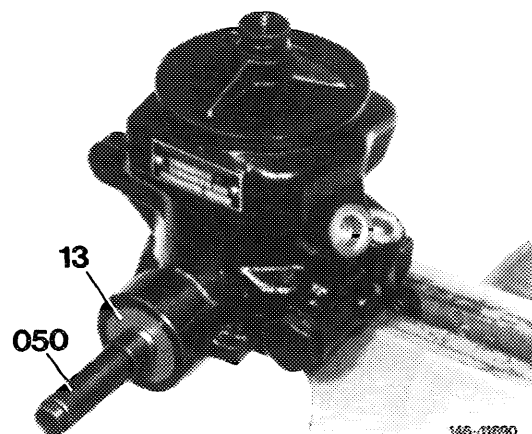

146-11890

3 Screw back hex. screw of puller (050) and slip device on drive shaft, while punching sealing lips of radial sealing ring (13) by means of 13 mm claws (051).

4 Turn clamping cone (arrow) of puller to the right up to stop, then pull sealing ring out of housing.

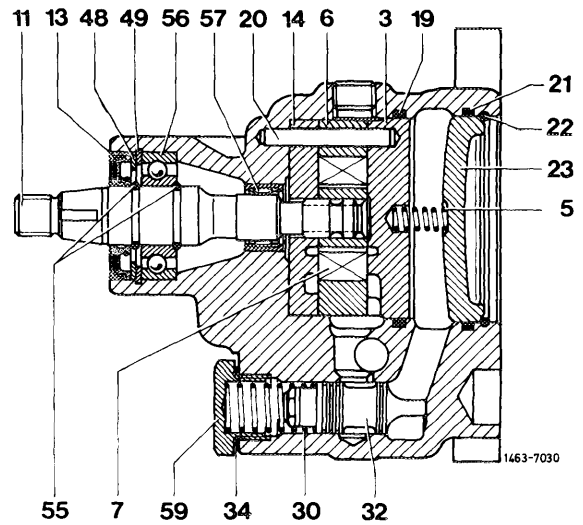
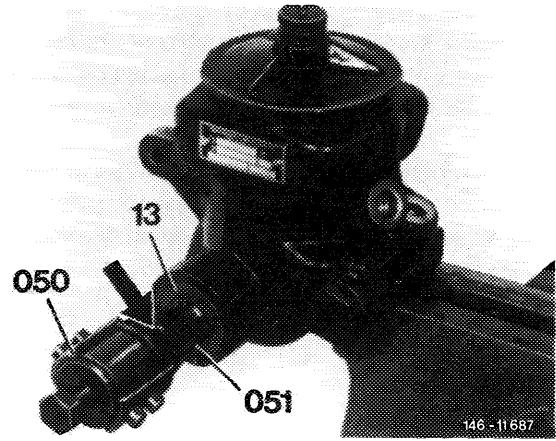

- 3 Pressure plate at cover end
- 5 Compression spring
- 6 Cam ring
- 7 Rotor with blade
- 11 Drive shaft
- 13 Sealing ring
- 14 Pressure plate at drive end
- 19 O-ring
- 20 Cyl. pin
- 21 O-ring
- 22 Hooked circlip
- 23 Cover
- 30 Compression spring
- 32 Volume control valve
- 34 Sealing ring
- 40 Lower steadying plate
- 41 Filter ring
- 42 Upper steadying plate
- 43 Compression spring
- 48 Washer
- 49 Locking ring
- 55 Circlip
- 56 Radial ball bearing
- 57 Needle bearing
- 58 Detent spring
- 59 Closing plug

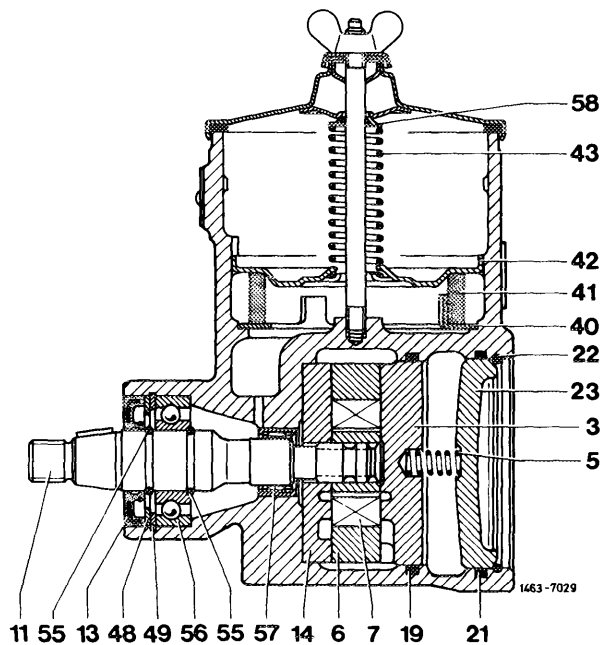

5 Remove washer (48).

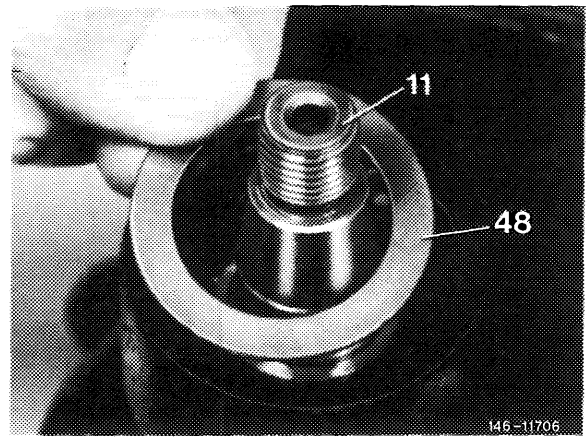

6 Unscrew knurled nut and remove closing cover.

7 Remove detent spring (58), compression spring (43) and upper steadying plate (42).

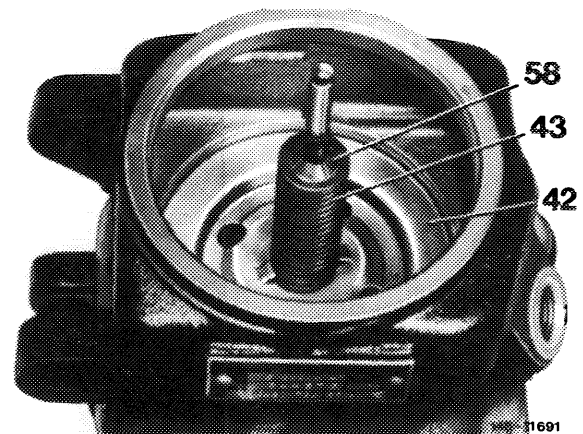

8 Remove filter ring (41) and lower steadying plate (40).

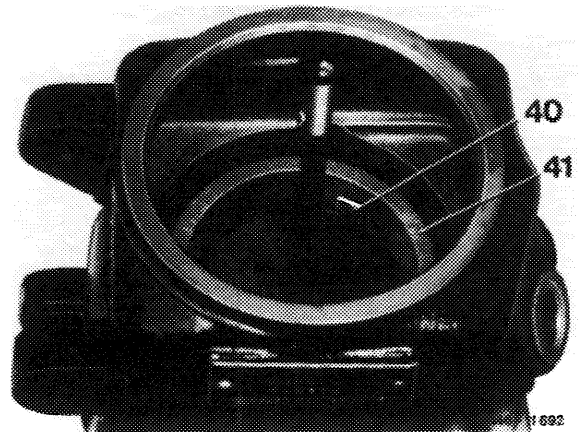

9 Place assembly sleeve (065) on power steering pump and push cover (23) slightly into housing by means of a screw clamp or a hand press.

10 Remove hooked circlip (22) from housing by means of a screwdriver. Then take off cover.

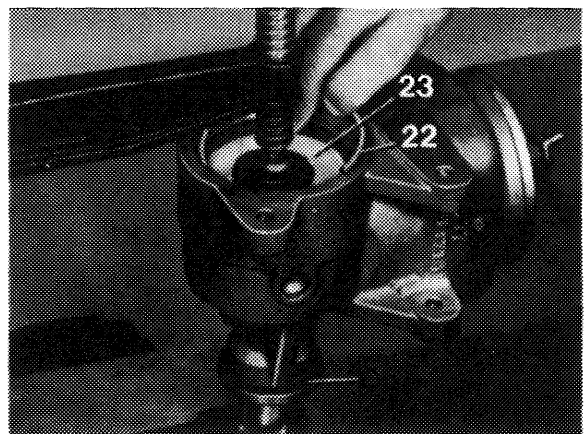

Note: The assembly sleeve is self-made according to specified dimensions.

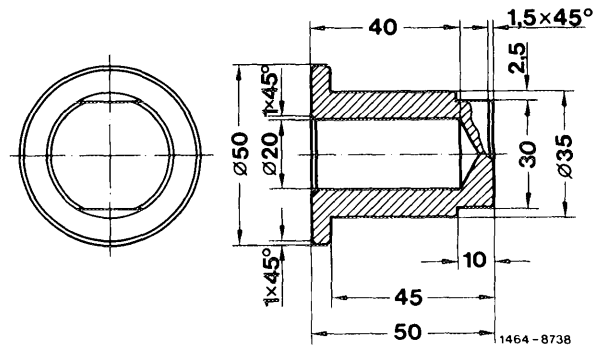

11 Remove O-ring (21), compression spring (5) and pressure plate (3) at cover end.

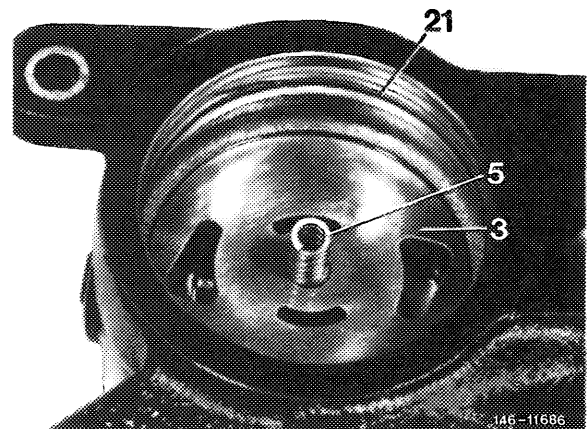

12 Remove rotor (7) with blades (16) from drive shaft.

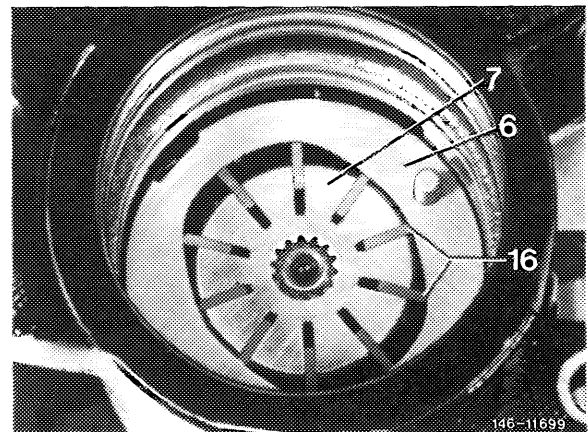

13 Remove O-ring and cam ring (6).

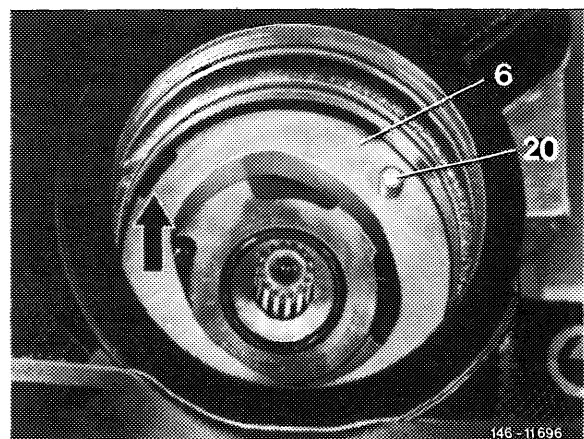

14 Remove locking ring (49) from housing.

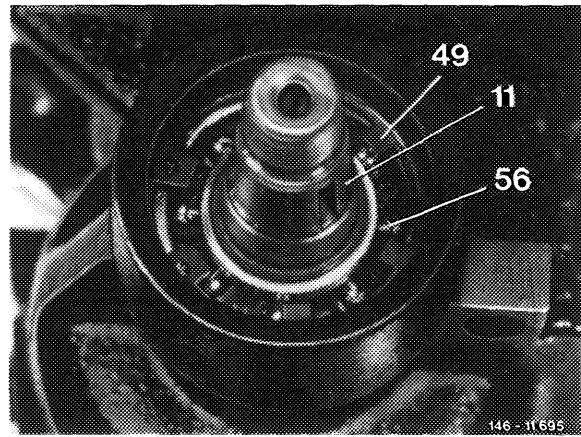

15 Press drive shaft out of housing.

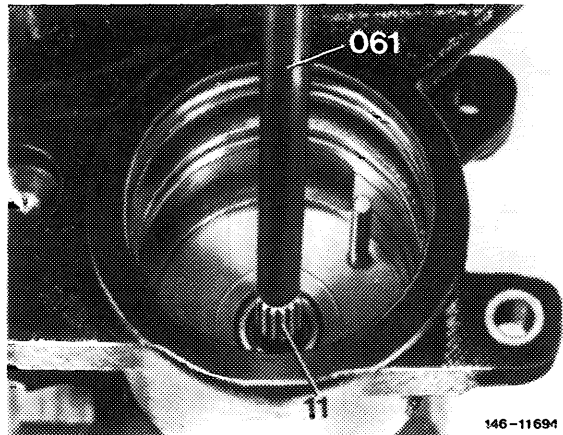

16 Remove circlips (55) from drive shaft and press bearing from shaft toward the rear in direction of splining.

Note: To make sure that the running surface for radial sealing ring is not damaged, remove circlips and radial ball bearing only toward the rear in direction of splining.

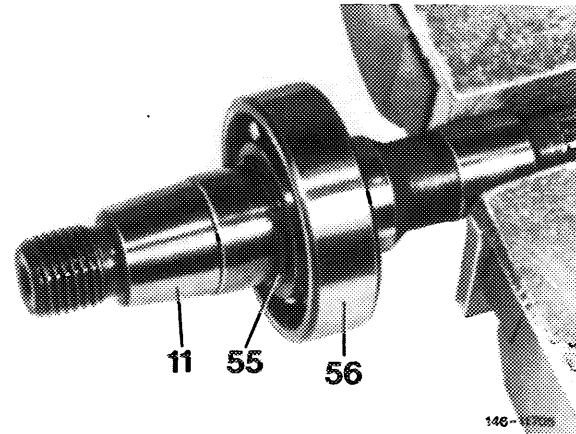

17 Knock needle bearing out of housing by means of a suitable mandrel.

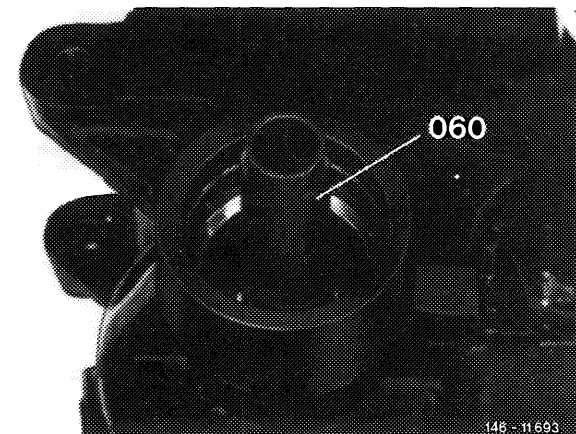

18 Screw closing plug (59) out of housing, remove compression spring (30) and volume control valve.

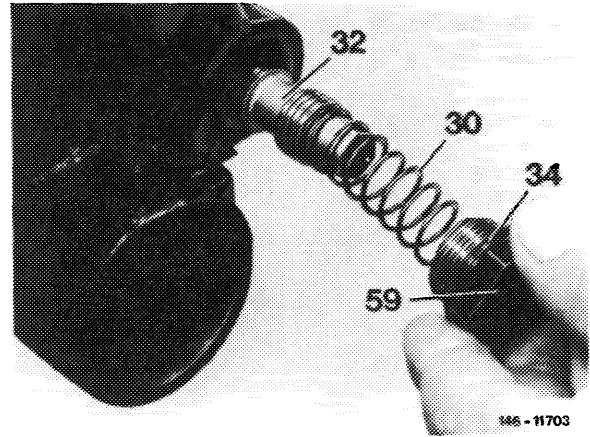

19 Clamp volume control valve (32) with its unground part into vise and unscrew valve screw. Pay attention to spacing washers (52). Remove ball (51) or valve cone (51) and compression spring (50).

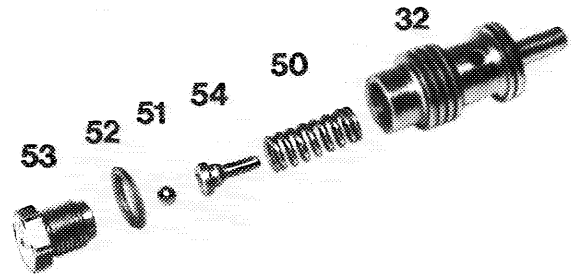

Pressure relief valve 1st version with ball

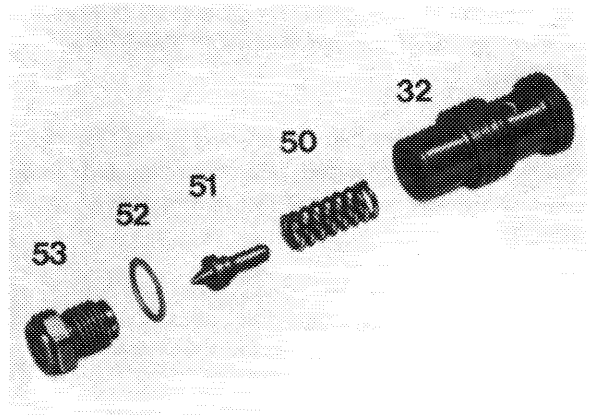

Pressure relief valve 2nd version with valve cone

Checking and reconditioning

Repair set

Designation	ZF power steering pump Grey iron	
Set of seals	000 586 84 46	
Pump insert	000 586 65 46	
Drive shaft	000 586 64 46	
Volume control valve	65 bar	000 586 62 46
	82 bar	000 586 63 46

20 Check ground surfaces of volume control valve (32) and bore in housing for wear and damage. If score marks show up on slide surfaces, replace complete power steering pump. Never replace volume control valve only.

- 3 Pressure plate at cover end
- 5 Compression spring
- 6 Cam ring
- 7 Rotor with blade
- 11 Drive shaft
- 13 Sealing ring
- 14 Pressure plate at drive end
- 19 O-ring
- 20 Cyl. pin
- 21 O-ring
- 22 Hooked circlip
- 23 Cover
- 30 Compression spring
- 32 Volume control valve
- 34 Sealing ring
- 48 Washer
- 49 Locking ring
- 55 Circlip
- 56 Radial ball bearing
- 57 Needle bearing
- 59 Closing plug

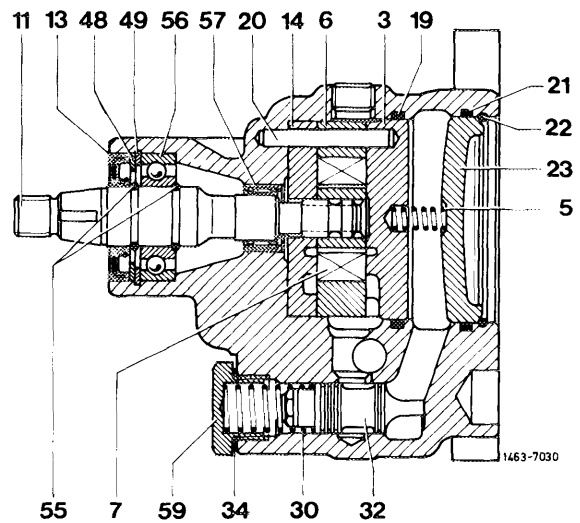

21 Check blades in grooves of rotor (7), they should slide easily in rotor. Check sliding surface of blades on cam ring (6) for wear. If required, recondition power steering pump by using repair set "pump insert".

Note: No noticeable marks should show up at slide surface of cam ring, since delivery capacity and smooth running of power steering pump depend on that surface.

- 3 Pressure plate at cover end
- 5 Compression spring
- 6 Cam ring
- 7 Rotor with blade
- 11 Drive shaft
- 13 Sealing ring
- 14 Pressure plate at drive end
- 19 O-ring
- 21 O-ring
- 22 Hooked circlip
- 23 Cover
- 40 Lower steadying plate
- 41 Filter ring
- 42 Upper steadying plate
- 43 Compression spring
- 48 Washer
- 49 Locking ring
- 55 Circlip
- 56 Radial ball bearing
- 57 Needle bearing
- 58 Detent spring

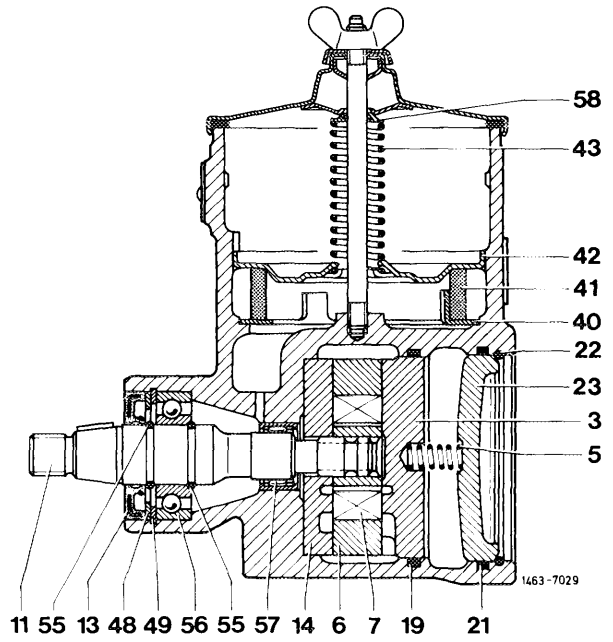

22 Check ground surfaces of pressure plates (3 and 14). If pressure plates are showing score marks, re-condition power steering pump by using repair set "pump insert".