

Removal

- 1 Disconnect battery negative terminal.
- 2 Pull off knob (3) (mounted conically).

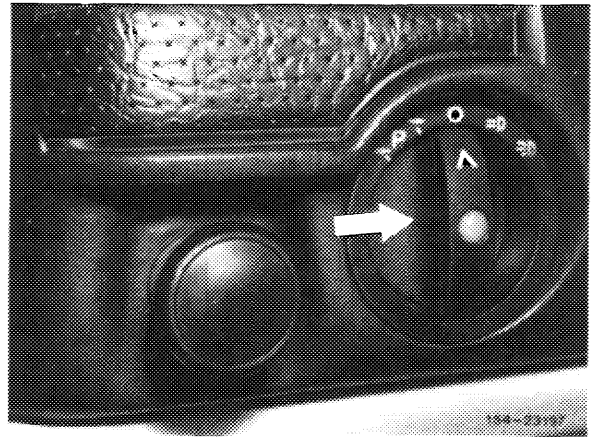

- 3 Unscrew nut and remove cover with symbols.
- 4 Remove cover under instrument panel left (68-150).

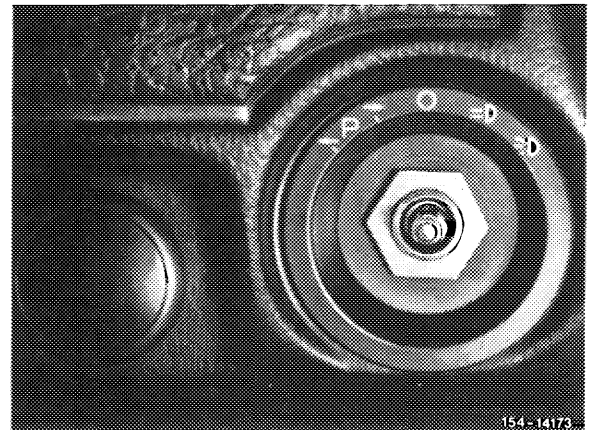

- 5 Remove rotary light switch from instrument panel in downward direction.

Installation

- 6 For installation proceed vice versa. Make sure that rotary light switch (1) and cover (2) are engaging in recess.

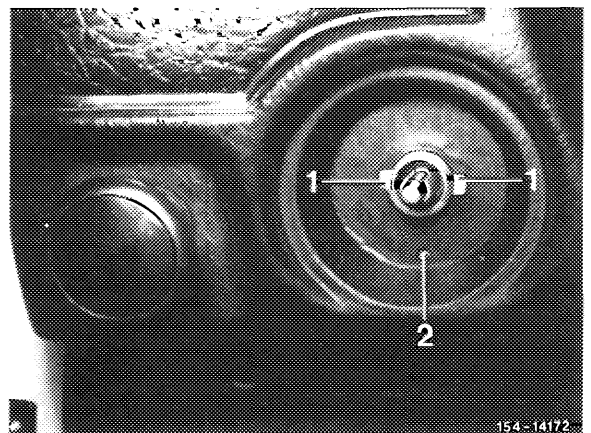

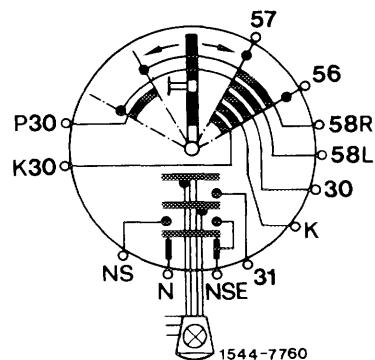

Connection diagram rotary light switch

Terminal	Designation	Line cross section mm ²	Cable color
30	Battery plus	6	red
K 30	Licence plate lamp input	0.75	grey/red
P 30	Standing lamp input	0.75	green/white
31	Ground for rear fog lamp	0.75	brown
56	Driving lamp	2.5	white/yellow
57	—	—	—
58 L	Parking-, tail lamp left	1.5	grey/white
58 R	Parking-, tail lamp right	1.5	grey
NSE	Rear fog and fog lamp input	1.5	grey/yellow/green
NS	Rear fog lamp output	0.75	grey/green/white
N	Fog lamp output	1.5	grey/green
K	Instrument lamps input	0.5	grey/green/purple
	Licence plate lamps, switch lamps	0.75	grey/purple