

In the event of complaints about automatic resetting of turnsignal arm, check installation of combination switch on jacket tube and resetting cam on steering shaft prior to installing a new switch.

1 Remove lining on legroom at driver's side, pull off plug of combination switch.

2 Pull off cover of combination switch, unscrew fastening screws of combination switch and loosen electric connections of horn (contact carbons). Pull out switch.

3 Measure dimension "a" at a distance of approx. 13 mm from center of tapped hole (M4) with depth gauge.

4 If dimension "a" is outside specified range, remove steering wheel.

5 Loosen fastening screws of plastic lining on jacket tube and remove plastic lining.

Dimension "a" = $20.2^{+0.4}_{-0.2}$ mm

Arrow: contact surface of combination switch

6 Clean contact surface (arrow) of combination switch on jacket tube from remaining paint, remove burr if required, and refinish contact surface carefully with a file, if required, until the required distance has been established.

7 If traces of wear are showing up on resetting tongue of combination switch, check radii of resetting cam on steering shaft. If the resetting cam is sharp-edged on resetting surfaces, the resetting tongue of combination switch will be worn out.

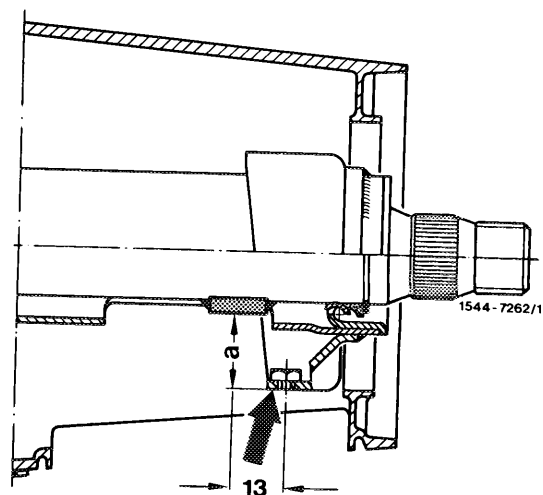

8 Refinish sharp-edged resetting cam e.g. with a conventional grinding point (diameter approx. 6 mm) until a radius of approx. 0.8 mm is attained (arrows).

9 Following assembly, which proceeds vice versa, perform function test; switch on turnsignal switch to the left and slowly turn steering wheel in clockwise direction to obtain resetting effect.

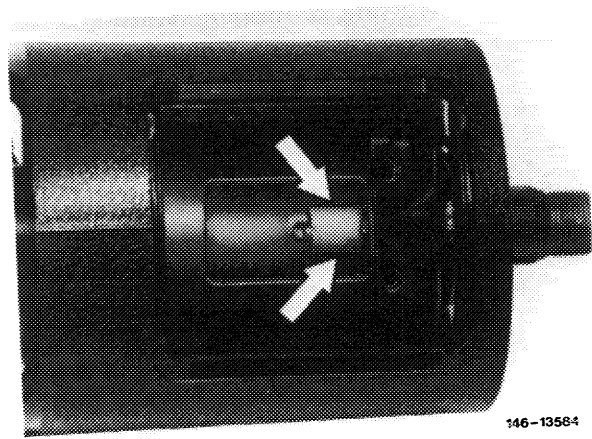

146-13584