

## 91–115 Remove and install vacuum element from driver's or co-driver's seat (coupe)

---

### Color coding of the vacuum lines for seat back locking system

---

Control line

light blue

---

### Remove

---

- 1 Pull control line (48) from connection piece (17).
- 2 Remove driver's seat.

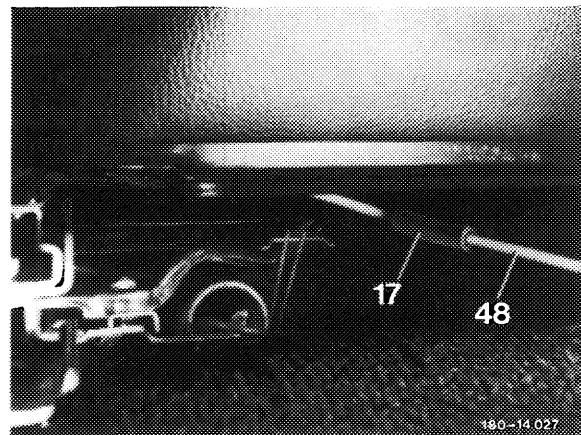

- 3 Drill out four hollow rivets (117) of the element retainer.

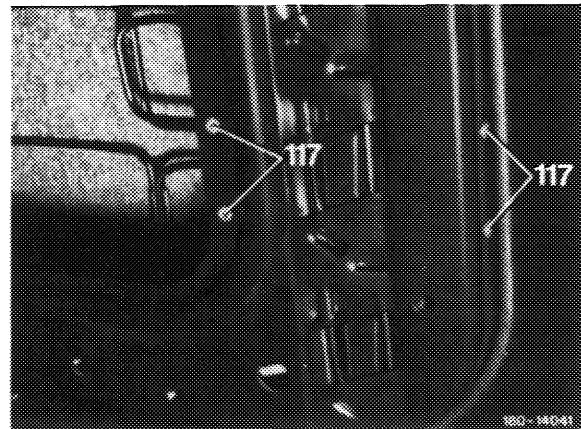

**Note:** For better view the following work is shown with the bare seat frame.

- 4 Remove distribution piece (22) from vacuum element (51).

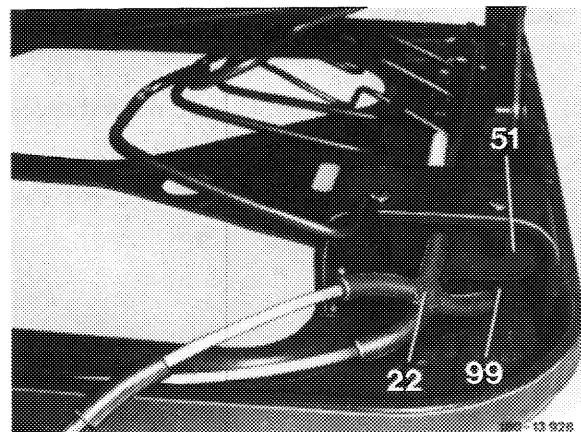

5 Unhook return spring (59).

6 Unhook securing clip (49) and remove vacuum element with operating rod.

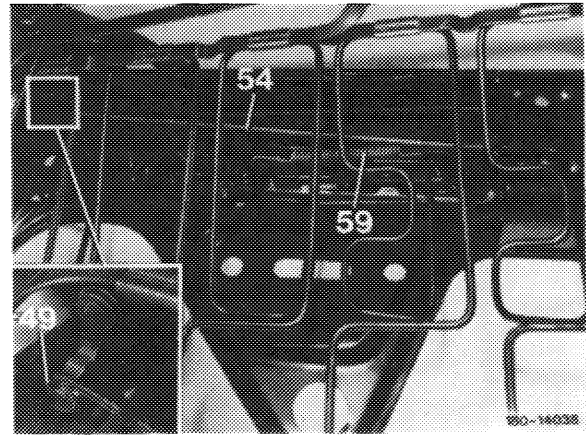

7 Unscrew lentil head screw (50) and remove element retainer (118).

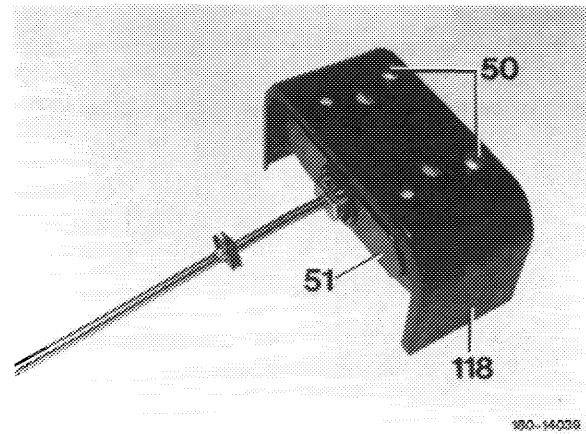

8 Pull out locking washer (43) and remove operating rod (54).

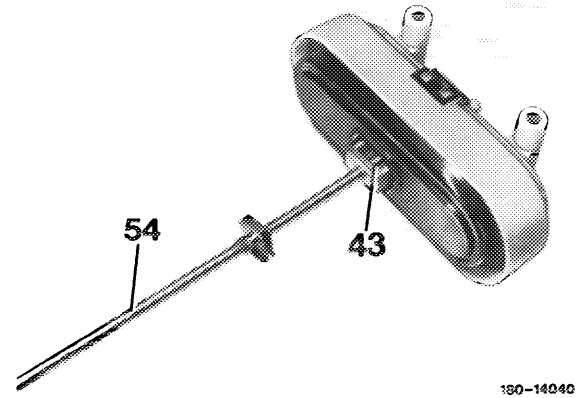

## Install

---

9 Fit operating rod (54) until it bottoms, and secure with lock washer (43).

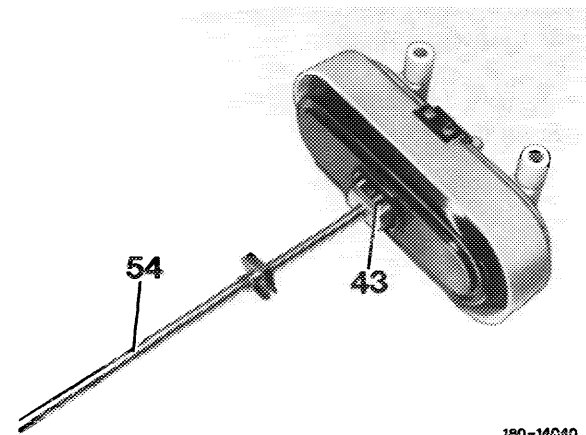

10 Attach element retainer (118) to vacuum element (51) with lentil head screws (50).

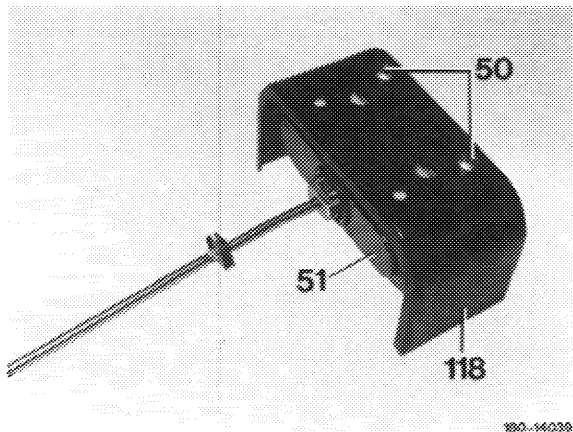

11 Install vacuum element with operating rod.

12 Secure operating rod (54) with securing clip (49).

13 Attach element retainer with four sheet metal screws to seat.

14 Fit return spring (59).

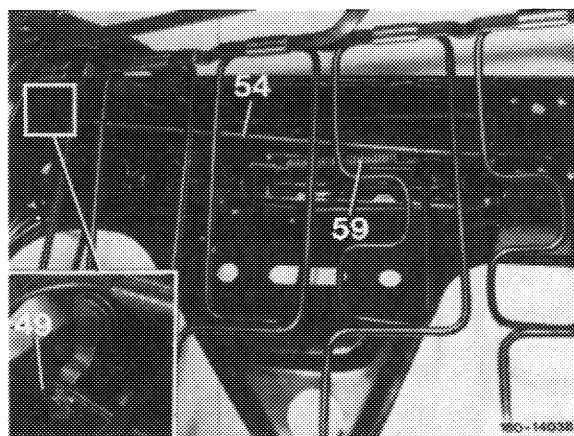

15 Push distribution piece (22) onto vacuum element.

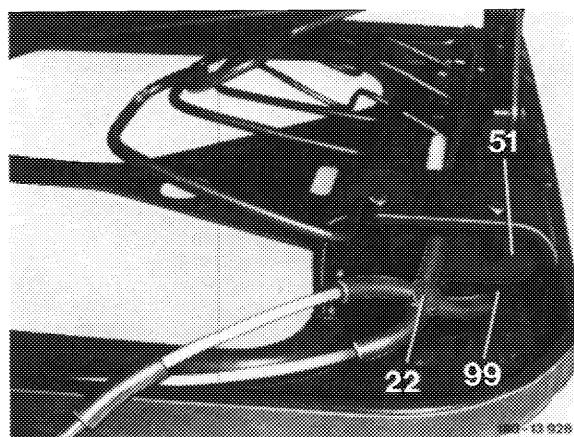

16 Install front seat.

17 Connect control line (48) to connection piece (17).

