

A. Sedan

Note

When reeling up belt, any noise caused by inertia reel is strictly functional.

In the event of a complaint, offending noises can be eliminated only by replacing the belt. Never apply oil or grease in an attempt to eliminate noise.

Also, never try to disassemble the inertia reel unit, since the preloaded spring may be the cause of injuries. Opened inertia reel units will cancel any pertinent warranty.

Removal

- 1 Push cap downwards and remove screw on side member (bright arrow).
- 2 Remove covering on center pillar (68–470).

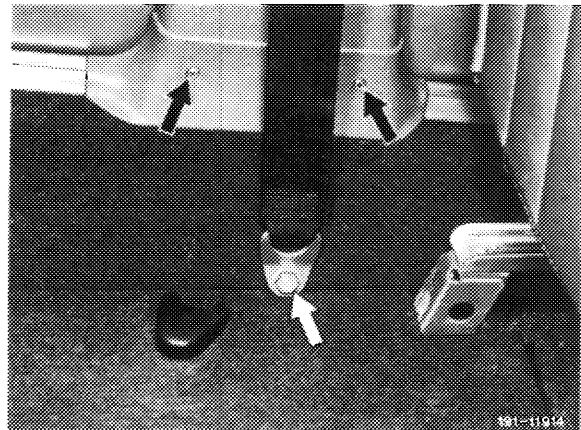

- 3 Insert belt with locking tongue through opening on covering.

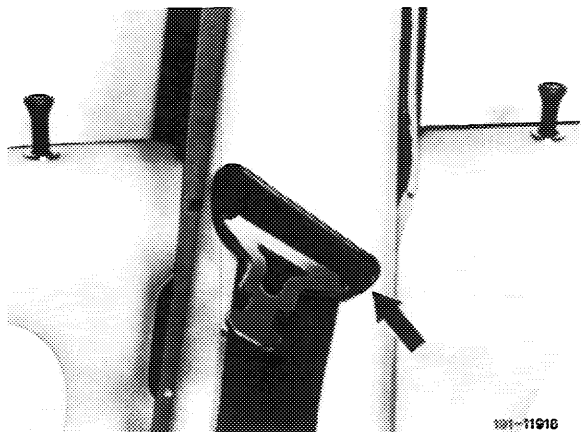

- 4 Remove screw on belt guide fitting.
- 5 Remove screw on automatic reel.
- 6 Slide front seat completely toward the rear.



- 7 Take cover molding from front seat and remove screw on belt lock.

Installation

- 8 For installation proceed vice versa.

Note: Insert screw on belt lock with screw locking compound Loctite product 241, part no. 002 989 94 71.

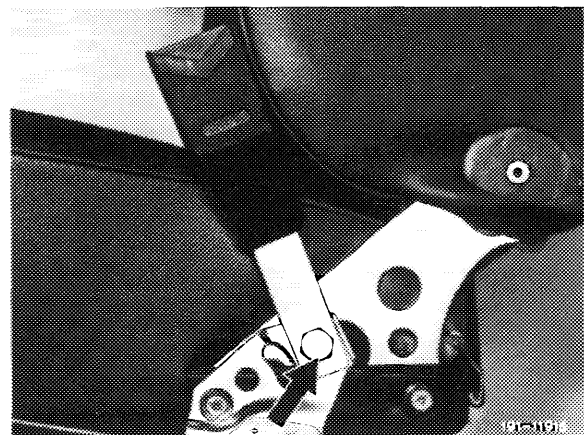

- 9 During installation of automatic reel, make sure of perfect seat in lock (arrow).

Following installation, check whether belt has been completely reeled in. To check, pull belt out diagonally in downward direction and return manually with lock tongue up to belt guide fitting.

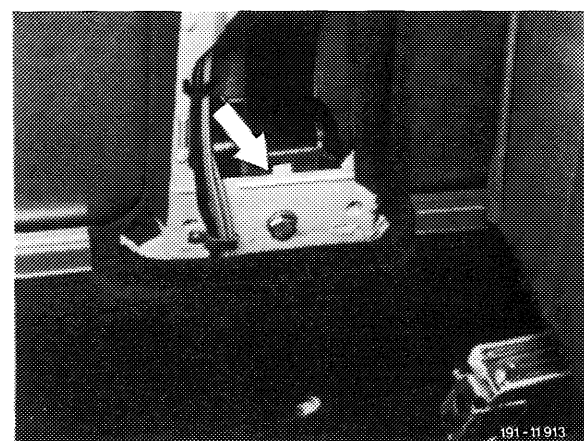

B. Coupe

Note

When the belt is retracted, noises in the belt retracting unit are due to the function.

In case of complaints, excessive noise can only be eliminated by exchanging the safety belt. On no account may oil or grease be used to eliminate the noise. The automatic retraction unit may also not be dismantled, as the preloaded spring can cause injuries. Automatic retracting units which have been opened are not accepted as warranty case.

Remove

1 Pull plate strap at swivel fitting on side member upwards.

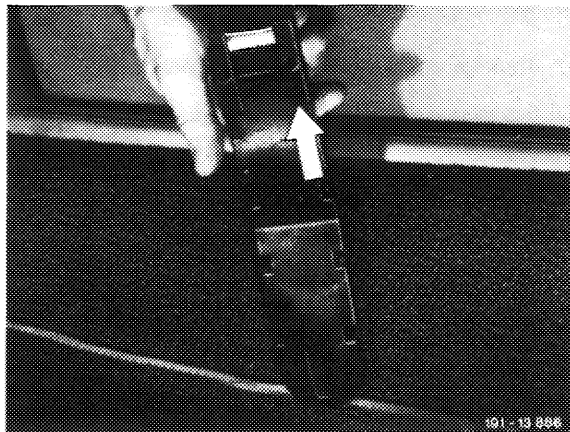

2 Open cover. To do so, insert the screw driver in the front slot and lift upper part of the cover from the lower part.

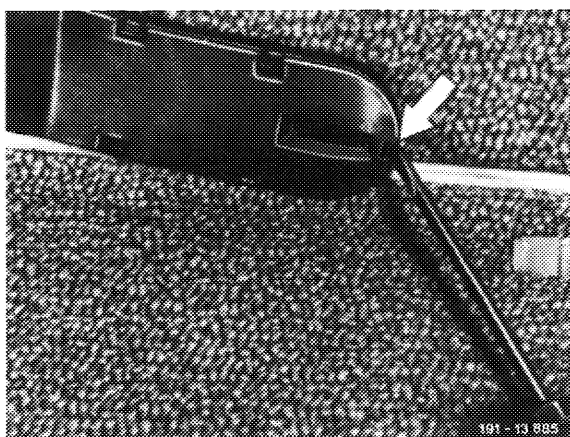

3 Remove screw at side member.

4 Remove rear quarter panel (68—456).

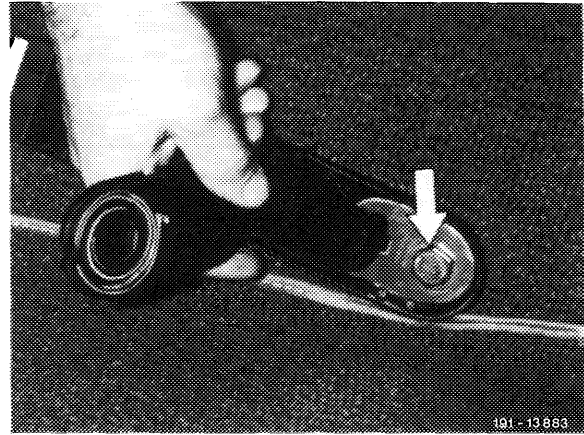

5 Unscrew screw at belt return fitting.

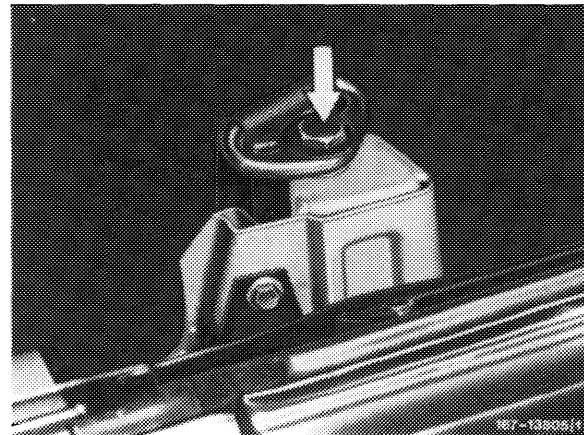

6 Remove screw at automatic retraction unit.

7 Remove driver's seat (91—100, section B).

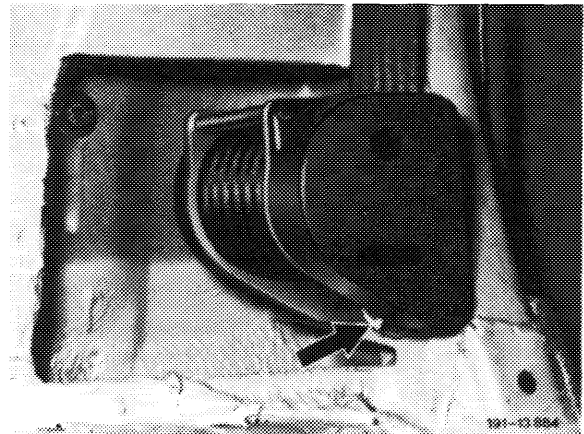

8 Remove cover plate from driver's seat and remove screw at belt lock.

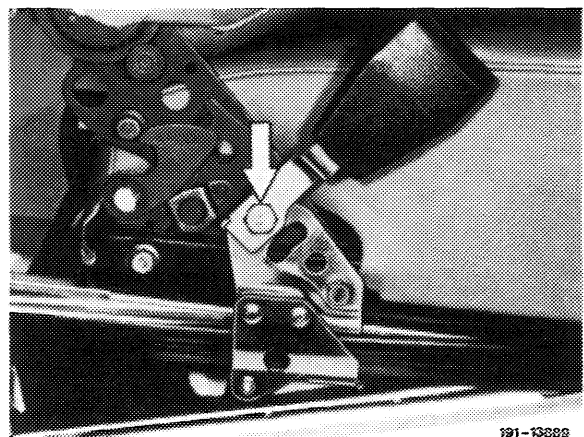

Installation

9 Screw-on belt lock.

Note: The screw at the belt lock must be installed with screw locking compound (Loctite product 241, part No. 002 989 94 71).

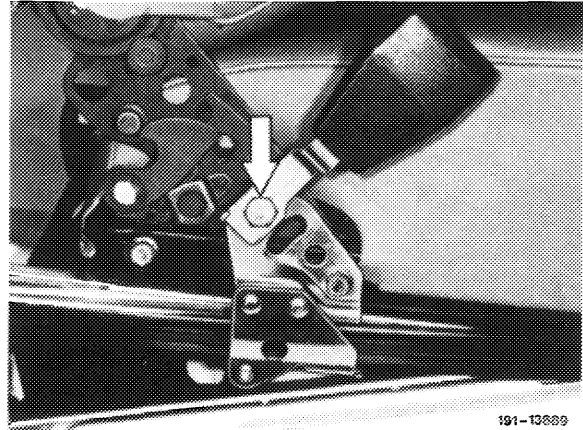

10 Screw-on automatic reel, while paying attention to perfect seat in lock (arrow).

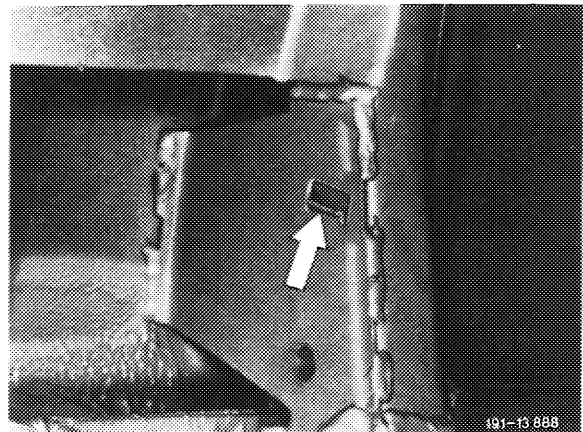

11 Insert coil spring with plastic element in top of swivel fitting and attach spring.

Fig. shows lefthand side, mirror image for righthand side.

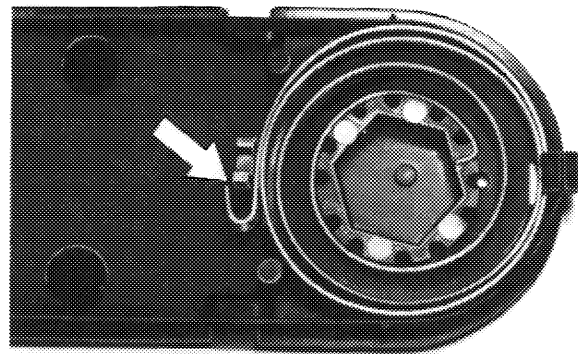

12 Insert Allen wrench into plastic insert and preload spring by 190°.

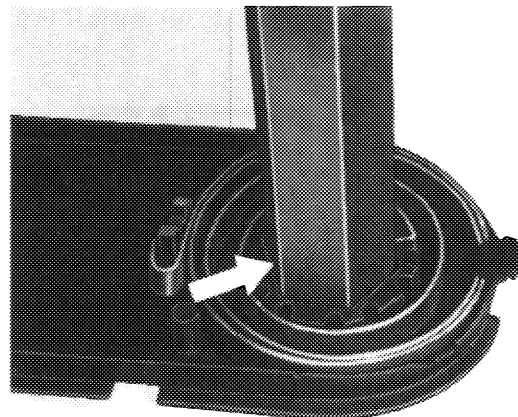

13 Lock preloaded plastic insert from back of top by means of special tool.

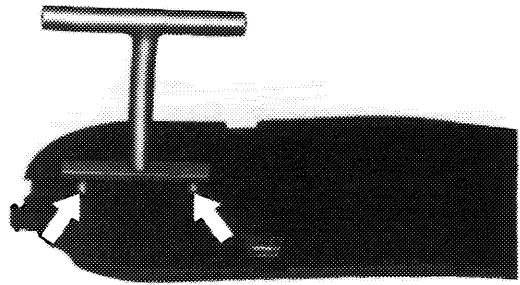

191-23125

Special tool (self-made)

- a = 45 mm
- b = dia. 4 mm
- c = 35 mm
- d = 8 mm
- e = dia. 4 mm
- f = dia. 2 mm
- g = 24 mm
- h = 40 mm
- i = 1.5 mm
- j = 8 mm

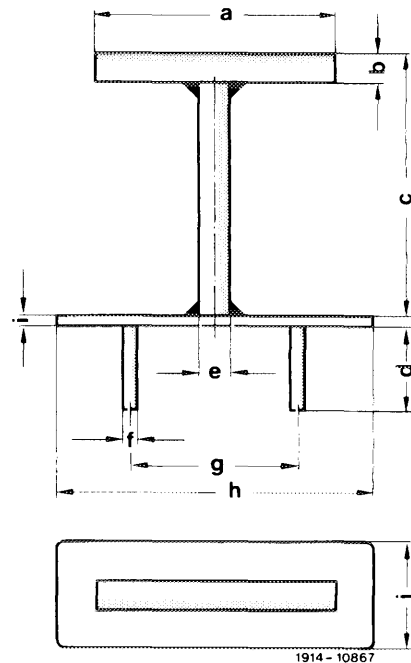

1914-10867

14 Pull Allen wrench from plastic insert and screw swivel fitting lower half to side member.

15 Set swivel fitting vertically and fasten top half with clips.

16 Pull off special tool.

Note: Swivel fitting on side member should pull the safety belt, if it is **not** worn, downwards into rear corner under influence of spring force, so that the formation of a drop loop will be prevented. Following installation, check whether belt is completely rolled up. To check, pull out belt diagonally in downward direction and return manually up to belt guide fitting together with lock tongue.

17 For further installation proceed vice versa.

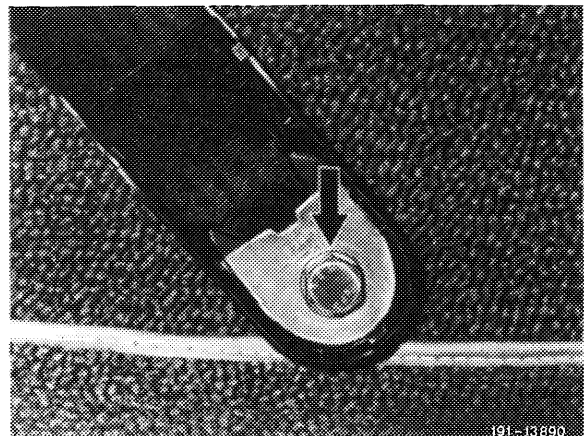

191-13890