

Data

Permissible leaks in system (without vacuum reservoir)	6 mbar/min at 400 mbar vacuum
Permissible leaks in components	20 mbar/min at 300 mbar vacuum
Plug-on length of connections	12 ± 2

Color code of vacuum lines for air-conditioning system

Vacuum line	Color code
Line from distributor to vacuum reservoir (16)	red-gray or gray-light blue
Suction line to vacuum switch (17)	green-yellow
Control line "cooling fresh air" (18)	green-light blue
Control line "cooling recirculating air" (19)	green-orange
Control line "leg room flap" (20)	green-white
Control line "defroster nozzle flap" (2nd version)	green-white

Special tool

Tester for vacuum systems

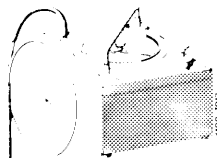

116 589 25 21 00

Note

For normal cooling the temperature switch is turned clockwise. The air-conditioner operates in range between 0 and mark on blue scale (approx. 3/4 cooling capacity) with fresh air (outside air).

For maximum cooling (temperature vacuum switch between mark and end of blue scale) the air-conditioner operates with recirculating air.

Checking vacuum system of air-conditioner without vacuum reservoir

1 Pull suction line green-yellow (17) out of distributor (9) and connect tester.

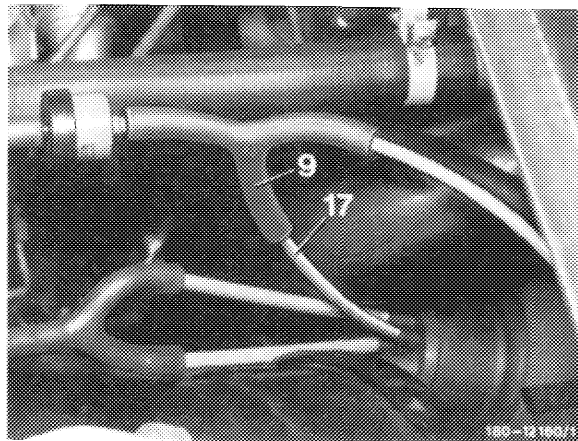

2 In position "cooling fresh air" evacuate system and read pressure increase on pressure gauge of tester. Check likewise in position "cooling recirculating air". Depending in which condition ("cooling fresh air" or "cooling recirculating air") the pressure increases, continue checkup according to section "leaks while cooling fresh air or cooling recirculating air". If a leak occurs in position according to section "cooling fresh air and recirculating air" continue checkup according to section "leaks while cooling fresh air and cooling recirculating air".

Attention!

Prior to exchanging vacuum elements, check hose lines and their connections in circuit found leaking.

Leaks while cooling fresh air or cooling recirculating air 1st and 2nd version

3 Remove cover under instrument panel right, as well as right and left starting with 2nd version.

4 Pull off connection with line green-light blue (18) or green-orange (19) of circuit found leaking.

5 Connect tester and evacuate.

6 If readout on pressure gauge changes while testing, replace vacuum element (12).

7 If readout on pressure gauge remains constant, the leak is at vacuum element (14) for leg room flap or on 2nd version at vacuum element (23) for defroster nozzle flap.

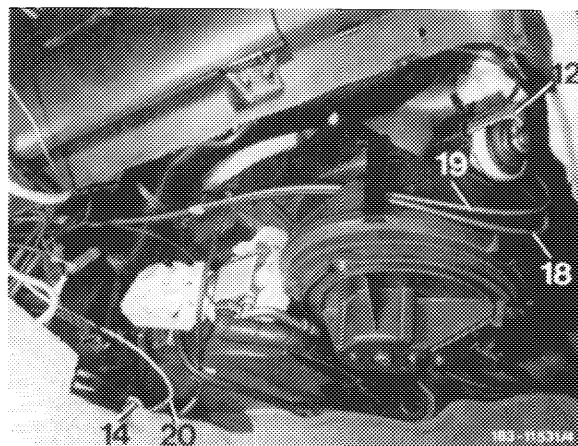

2nd version

Vacuum element for defroster nozzle flap, lefthand steering starting 03/79 as well as righthand steering starting 11/79 to 08/80

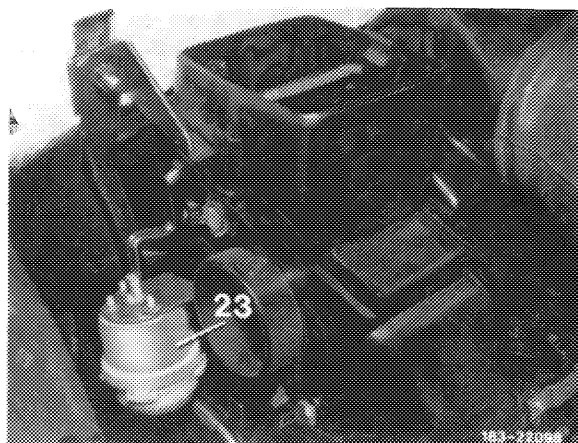

8 In such a case, pull connection with line green-white (20) from vacuum element (14) or on 2nd version from vacuum element (23).

9 Connect tester in each case to vacuum element (14) and (23) and evacuate.

10 If a vacuum element is leaking, readout on pressure gauge will change.

11 Renew leaking vacuum element.

Leaks while cooling fresh air and cooling recirculating air (1st and 2nd version)

12 If both circuits are leaking, leak may be in check valve.

13 Pull check valve (8) out of distributor (9) and connect tester with connecting hose (refer to arrow), evacuate and read pressure gauge.

14 If readout on pressure gauge is not changing, check valve is leaktight. If both circuits are still leaking, the fault is with temperature vacuum switch.

15 In such a case, remove temperature vacuum switch.

Note: The temperature vacuum switch comprises the temperature switch as well as a vacuum rotary switch (4) for recirculating air flap and a vacuum pull switch (5) for leg and rear compartment flap, as well as from 2nd version for defroster nozzle flap.

16 Pull control line green-light blue (18) and green-orange (19) from connections (17).

17 Pull connecting bridge (112) from vacuum pull switch (5).

18 Close connecting bridge (112) and connections (17) with blind plugs (84).

19 Pull suction line from vacuum rotary switch, connect tester (refer to arrow) and evacuate.

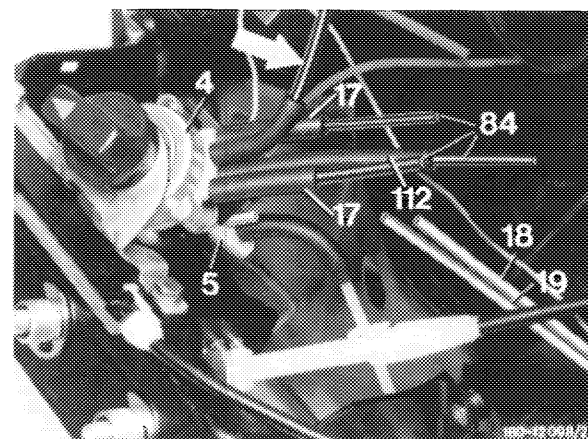
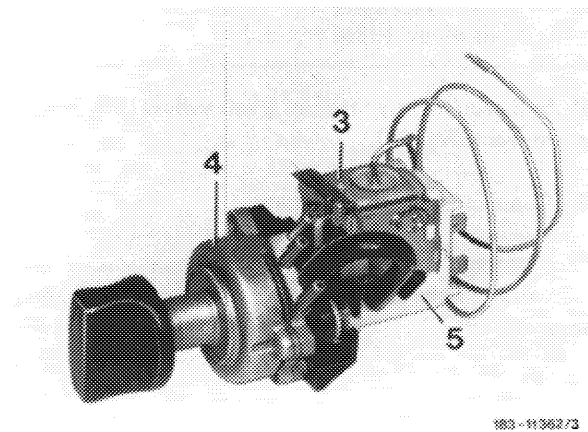
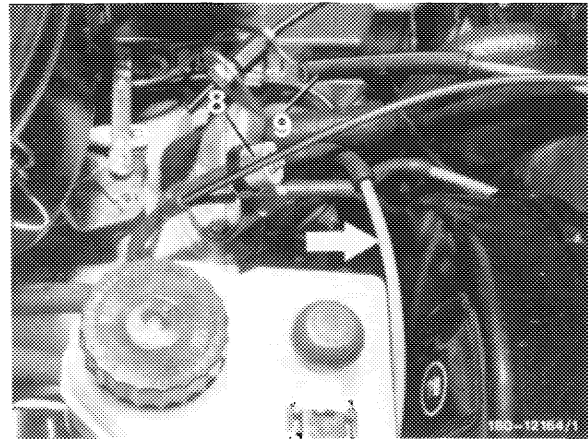

- 20 Turn vacuum rotary switch (104) from position "cooling fresh air" to end stop and read pressure gauge.
- 21 If readout on pressure gauge changes, replace vacuum rotary switch.
- 22 If readout on pressure gauge remains constant, the vacuum rotary switch is leaktight and the leak is at vacuum pull switch.
- 23 In such a case, pull control line green-white (20) out of connection (17) and close with blind plug (84).
- 24 Pull of connecting bridge (112) at vacuum pull switch (5) and connect tester with connecting hose (refer to arrow).
- 25 Evacuate vacuum pull switch with tester.
- 26 If vacuum pull switch leaks in pulled or pushed position, readout on pressure gauge will change.
- 27 Replace vacuum pull switch.

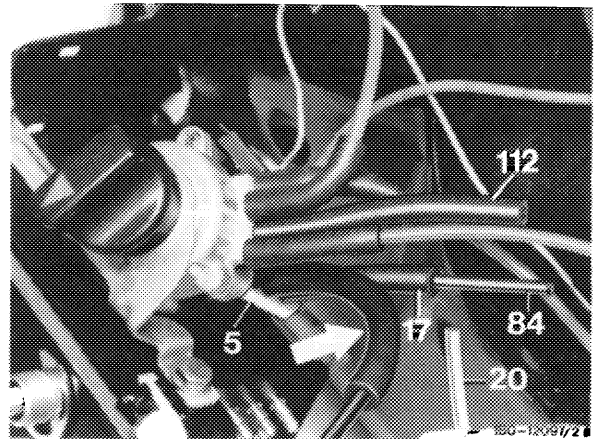

In the event of leaks (3rd version)

- 28 Pull vacuum line medium green-yellow (17) from switchover valve (18).
- 29 Connect tester and evacuate.
- 30 If readout on pressure gauge changes during test, pull vacuum hose (20) from vacuum element (12) and close.

3rd version

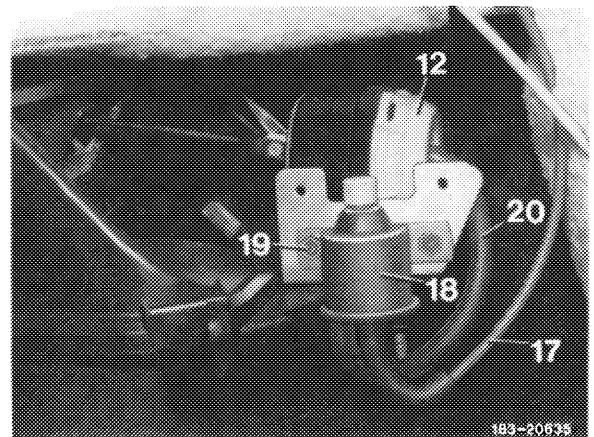

- 31 Evacuate with tester, if readout on pressure gauge remains constant during test, renew vacuum element (12).

Checking vacuum reservoir

28 Pull suction line red-gray or gray-light blue (16) from distributor (9). Connect tester with connecting hose (refer to arrow) to suction line (16) and evacuate.

29 If readout on pressure gauge changes, replace sealing of vacuum reservoir or vacuum reservoir, if required.

