

The manual test permits checking the function (operation) of all components of automatic climate control system.

Additional tests for finding the cause of the fault are only required in the event of deviations from the functions or air outlets shown here.

Run engine at idle and at operating temperature during entire test.

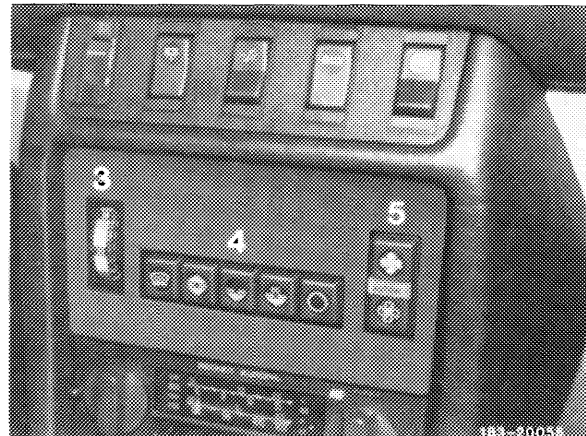

3 Temperature dial  
4 Pushbutton switching unit  
5 Blower switch

Open swivel inserts for air outlet center, left and right.  
Remove glove box (68-140).

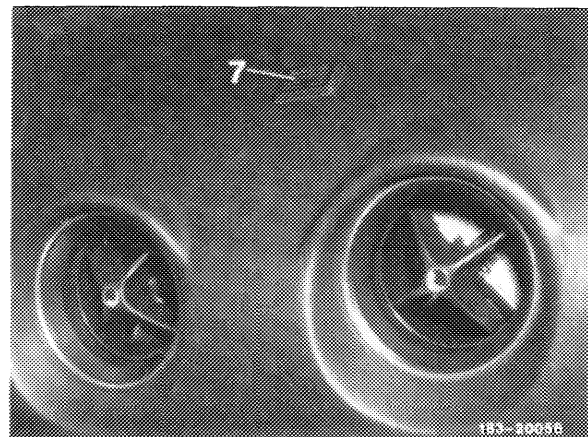

### Note

---

1. During electric test on 2-pole coupler of mono-valve (with voltmeter, test lamp) be sure to avoid a short, which may destroy the electronic switching unit for temperature control.
2. At room temperatures  $> 25^{\circ}\text{C}$  the cycling of the heating water valve cannot be readily shown during second and sixth test. For this purpose, the vehicle interior should be cooled down to approx.  $22^{\circ}\text{C}$  (with doors and windows, as well as sliding top) closed.
3. Other tests can be made with an adapter for automatic climate control 126 589 03 21 00.

**4. Illustration of special operating conditions:**

Only one button at the time should be pushed, on principle. The operating conditions described below are therefore not included in test scope. They are mentioned only to assist customers if such a condition has been established by chance. No damage will occur, even if the vehicle is driven for an extended period.

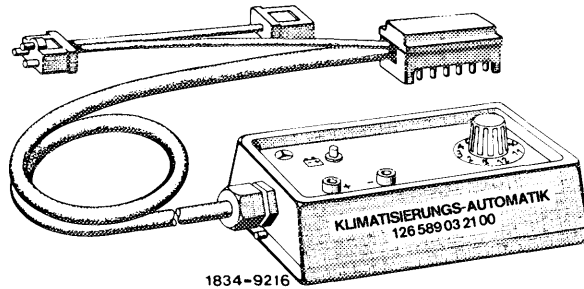

- a) **All buttons "a" – "e" not pushed:**  
Operating condition similar to "c", but the lowest automatic blower stage will then be raised to 3rd stage.
- b) **Button "e" pushed in combination with another button:**  
System always in switched-off condition.

- c) **Buttons "c" and "d" pushed at the same time:**  
Operating condition similar to "d", but 3rd blower stage will drop to 2nd stage.
- d) **Buttons "b" and "c" pushed at the same time:**  
Operating condition similar to "b", but 3rd blower stage will drop to 2nd stage.

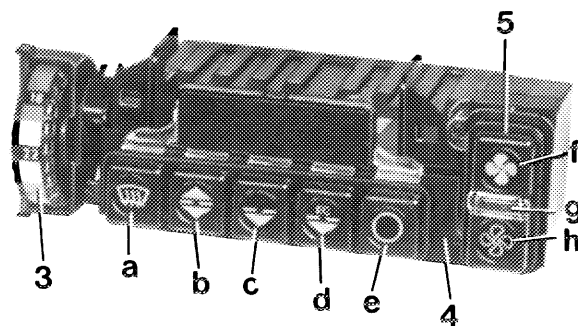

- e) **Buttons "a" and "b" pushed at the same time:**  
Operating condition similar to "a", but legroom flaps will be additionally open.
- f) **Operation of button "a" (DEF) will always predominate in relation to selector dial and blower.**
- g) **Buttons "b" and "d" pushed at the same time:**  
Function similar to "b", but compressor will be switched off.

183 - 17660/1

Significance of arrows in graphic displays of tests 1–12.

|                   | Arrows, large | Arrows, small |
|-------------------|---------------|---------------|
| Outside air       | Gray          |               |
| Cooled air        | Black         |               |
| Heated air        | White         |               |
| Air outlet (warm) |               | White         |

**Test 1:**

| Selector dial | Function button | Blower  |
|---------------|-----------------|---------|
| 22 °C         | "e"             | "AUTOM" |

- Monovalve closed.
- Compressor switched off.
- Main air flap closed.
- Blower not running.
- Recirculating pump not running.

The electronic system is ready for operation.

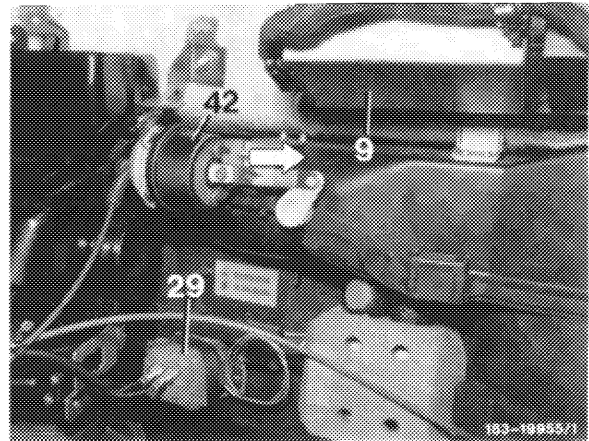
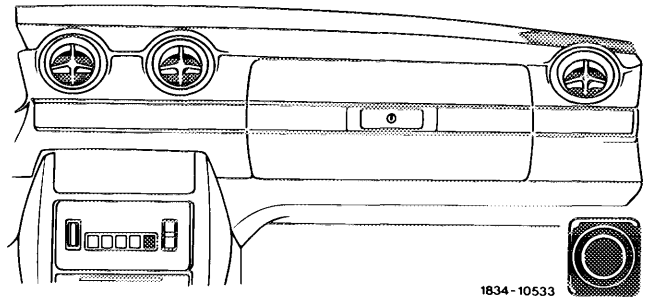

Main air flap closed (arrow), no fresh air supply

**Test 2:**

| Selector dial | Function button | Blower  |
|---------------|-----------------|---------|
| 22 °C         | "c"             | "AUTOM" |

Establish condition "mode change" (overlap) by turning temperature dial slowly in upward or downward direction until legroom flaps and center nozzle flap are open.

- Monovalve cycling (every 4 to 5 seconds).  
At temperatures > 25 ° refer to 83-601, item 1.
- Compressor switched on at outside temperatures above + 2 °C
- Main air flap open (fresh air).
- Blower starts after approx. 10 seconds.
- Recirculating pump running.

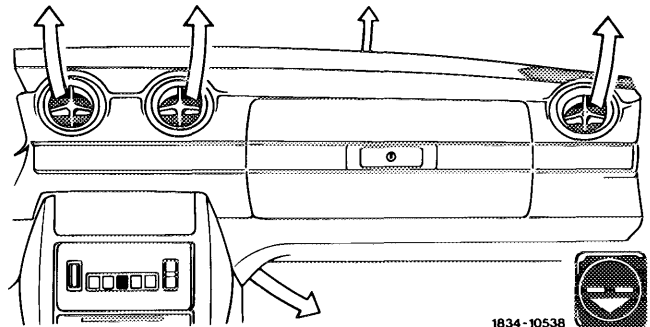

- Control unit
- 3 Temperature dial
  - 5 Blower switch
  - a-e Function selection buttons
  - f Max. blower stage (6th stage)
  - g Automatic blower (2nd-5th stage)
  - h Minimum blower stage (1st stage)

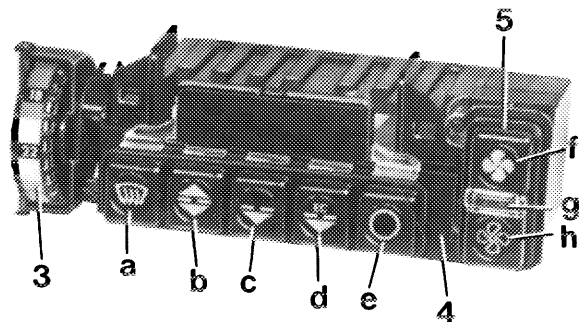

### Test 3

| Selector dial | Function button | Blower  |
|---------------|-----------------|---------|
| MIN (engaged) | "b"             | "AUTOM" |

- Monovalve closed.
- Recirculating valve not running.
- Compressor switched on at outside temperatures  $> 2^{\circ}\text{C}$ .
- Fresh air-recirculating air flap in position "re-circulating air" (20 % fresh air, 80 % recirculating air).
- Main air flap open.
- Blower runs (10 V or 5th stage).

Also refer to vacuum function diagram 2 b (83–604).

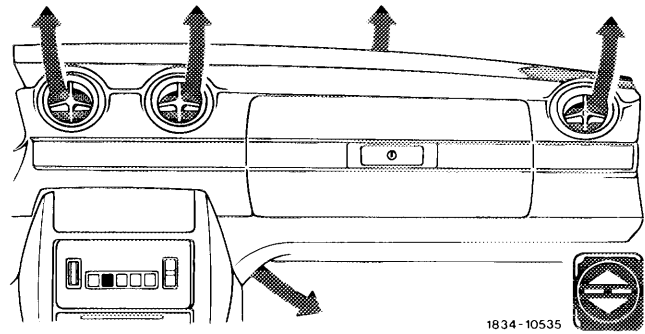

1834-10535

Vacuum element 41 for fresh air-recirculating air flap in position "recirculating air"

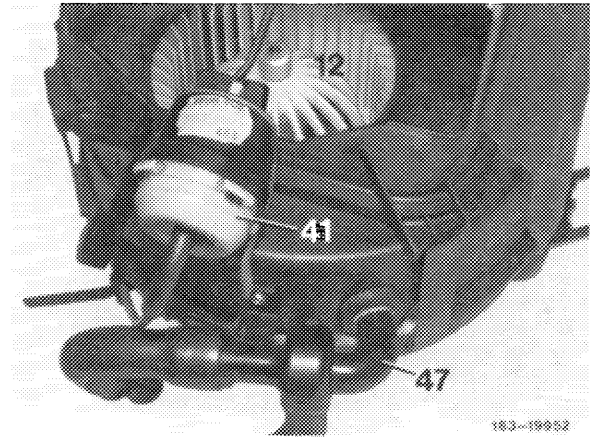

183-19852

### Test 4

| Selector dial | Function button | Blower  |
|---------------|-----------------|---------|
| MIN (engaged) | "d"             | "AUTOM" |

- Monovalve closed.
- Recirculating valve not running.
- Compressor switched off.
- Fresh air-recirculating air flap in position "fresh air".
- Main air flap open (fresh air).
- Blower running (10 V or 5th stage).

Also refer to vacuum function diagram 4 a (83–604).

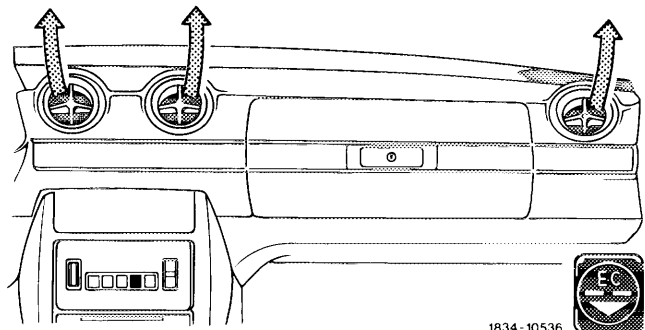

1834-10536

Fresh air-recirculating air flap in position "fresh air" (arrow)



183-2181

**Test 5:**

| Selector dial | Function button | Blower |
|---------------|-----------------|--------|
| MIN (engaged) | "c"             | "h"    |

- Center nozzle flap open.
- Monovalve closed.
- Fresh air-recirculating air flap in position "recirculating air" (20 % fresh air, 80 % recirculating air).
- Main air flap open.
- Recirculating pump not running.
- Blower running (4 V or 1st stage).

Also refer to vacuum function diagram 3 b (83-604).

Significance of arrows in graphic displays of tests 1-12.

|                   | Arrows, large | Arrows, small |
|-------------------|---------------|---------------|
| Outside air       | Gray          |               |
| Cooled air        | Black         |               |
| Heated air        | White         |               |
| Air outlet (warm) |               | White         |

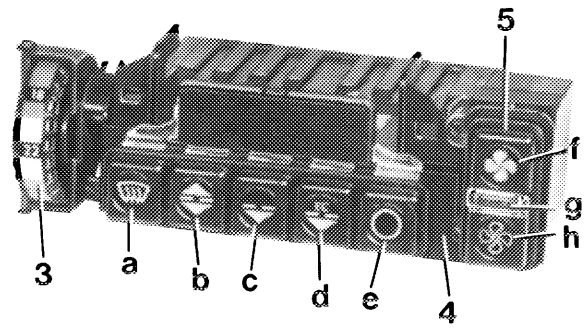

183-17660/1

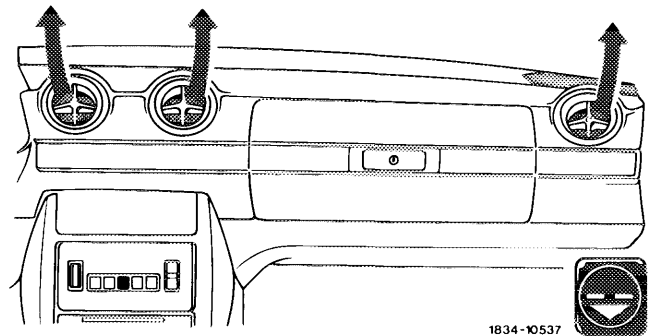

1834-10537

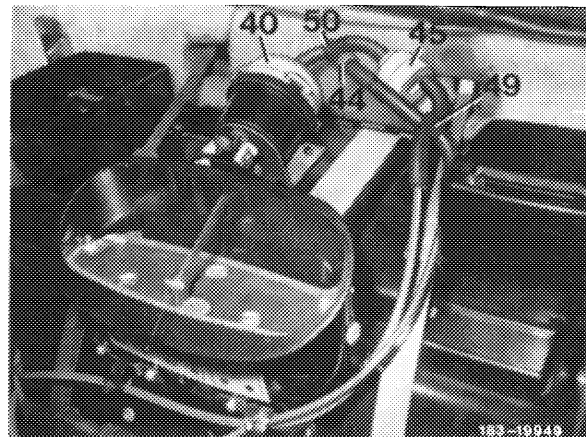

- 40 Vacuum element for center nozzle flap
- 44 Throttle (orifice)
- 45 Check valve
- 49 4-point distributor
- 50 3-point distributor

183-19949

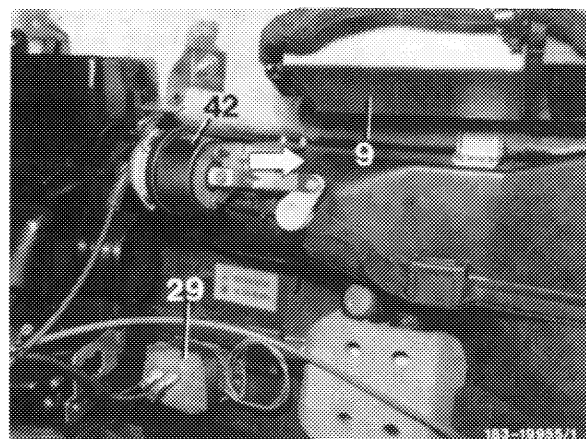

- Main air flap closed (arrow)
- 9 Electronic switching unit for temperature control
- 29 ETR-switch
- 42 Vacuum element for main air flap

183-19955/1

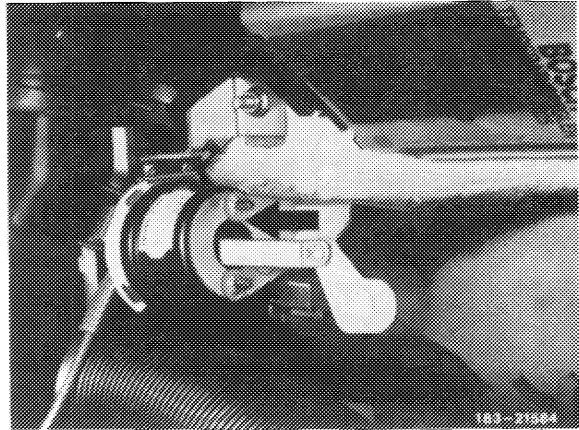

Main air flap opened (arrow)

**Test 6:**

| Selector dial | Function button | Blower  |
|---------------|-----------------|---------|
| 22 °C         | "c"             | "AUTOM" |

Set up condition "mode change" (overlap) by slowly turning temperature dial in upward or downward direction until legroom flaps and center nozzles are opened. Wait until blower has switched to 5 V or 2nd stage.

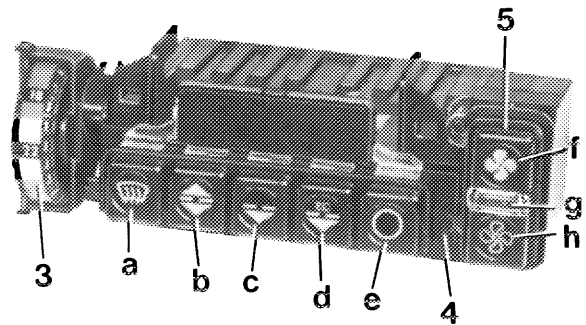

183-17660/1

5 V on blower = preparation for next test!

- Monovalve cycling (every 4 to 5 seconds). At temperatures  $> 25\text{ }^{\circ}\text{C}$  refer to job no. 83-601, item 2.
- Compressor switched on at outside temperatures above  $+ 2\text{ }^{\circ}\text{C}$ .
- Main air flap open (fresh air).
- Fresh air-recirculating air flap in position "fresh air" (arrow).
- Recirculating pump running.

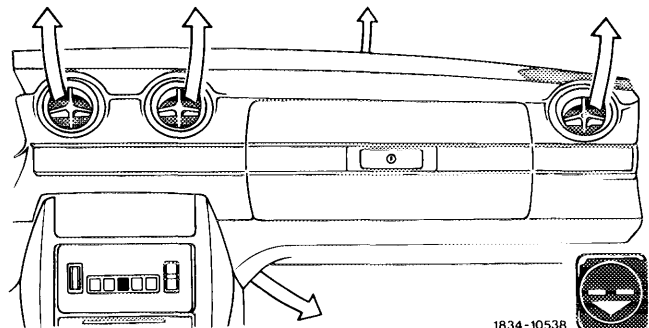

1834-10538

Significance of arrows in graphic displays of tests 1-12.

|                   | Arrows, large | Arrows, small |
|-------------------|---------------|---------------|
| Outside air       | Gray          |               |
| Cooled air        | Black         |               |
| Heated air        | White         |               |
| Air outlet (warm) |               | White         |



183-21101

**Test 7:**

| Selector dial | Function button | Blower  |
|---------------|-----------------|---------|
| 22 °C         | "d"             | "AUTOM" |

- Blower switches one stage higher (from 5 V to 6.5 V or from 2nd to 3rd stage).
- Monovalve cycling (every 4–5 seconds).
- Compressor switched off.
- Main air flap opened (fresh air).
- Fresh air-recirculating air flap in position "fresh air" (arrow).
- Recirculating pump running.

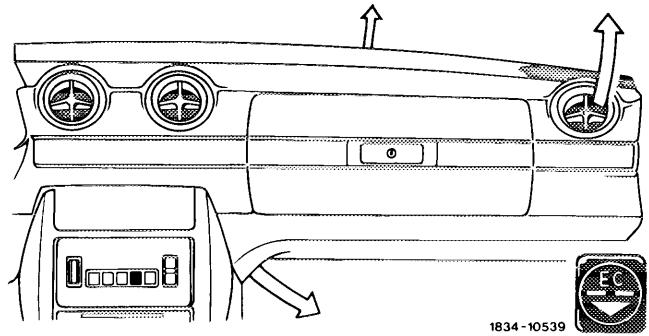

1834-10539

**Test 8:**

| Selector dial | Function button | Blower |
|---------------|-----------------|--------|
| 22 °C         | "d"             | "f"    |

- Blower running at max. speed (6th stage).
- Monovalve cycling (every 4–5 seconds).
- Compressor switched off.
- Fresh air-recirculating air flap in position "fresh air".
- Main air flap open (fresh air).
- Recirculating pump running.

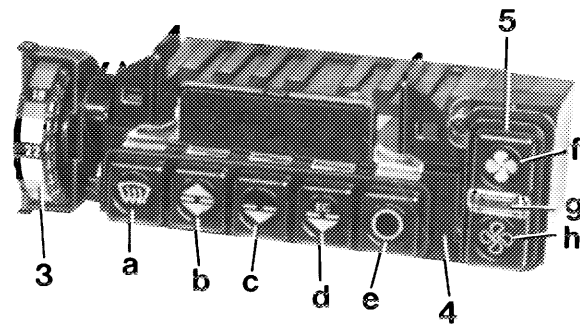

183-17660/1

Significance of arrows in graphic displays of tests 1–12.

|                   | Arrows large, | Arrows, small |
|-------------------|---------------|---------------|
| Outside air       | Gray          |               |
| Cooled air        | Black         |               |
| Heated air        | White         |               |
| Air outlet (warm) |               | White         |

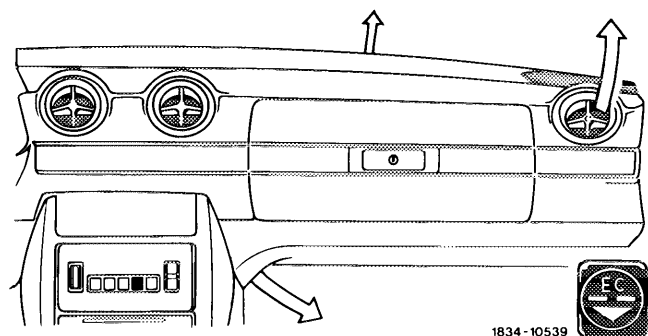

1834-10539

**Test 9:**

| Selector dial | Function button | Blower  |
|---------------|-----------------|---------|
| MAX (engaged) | "c"             | "AUTOM" |

- Monovalve opened.
- Recirculating pump running.
- Compressor switched on at outside temperatures above +2 °C.
- Blower running (10 V or 5th stage).
- Center nozzle flap closed (no air from center nozzle).
- Main air flap opened (fresh air).

Also refer to vacuum function diagram 3 (83–604).

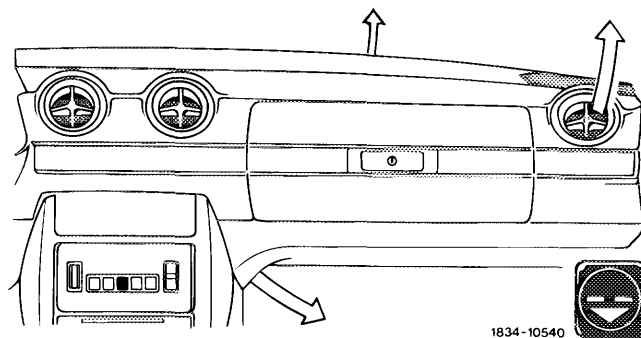

1834-10540

**Test 10:**

| Selector dial | Function button | Blower   |
|---------------|-----------------|----------|
| Optional      | "a"             | Optional |

- Blower running at max. speed (6th stage).
- Monovalve open.
- Recirculating pump running.
- Compressor switched on at outside temperatures > 2 °C.
- Fresh air-recirculated air in position "fresh air" (arrow).
- Main air flap open.

Also refer to vacuum function diagram 1 (83–604).

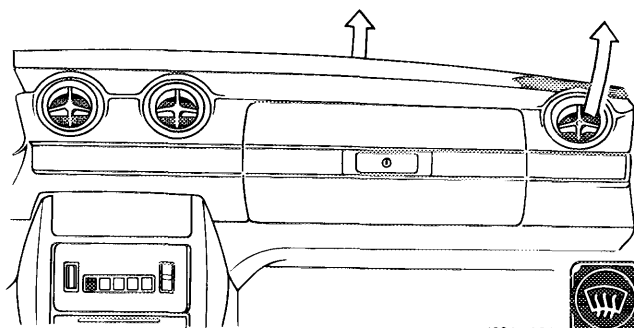

1834-10541



183-2181



**Test 11:**

| Selector dial | Function button | Blower |
|---------------|-----------------|--------|
| MIN           | "b"             | "f"    |

- After switching to "b", cold air should come immediately out of center and side nozzles.

Significance of arrows in graphic displays of tests 1–12.

|                   | Arrows, large | Arrows, small |
|-------------------|---------------|---------------|
| Outside air       | Gray          |               |
| Cooled air        | Black         |               |
| Heated air        | White         |               |
| Air outlet (warm) |               | White         |

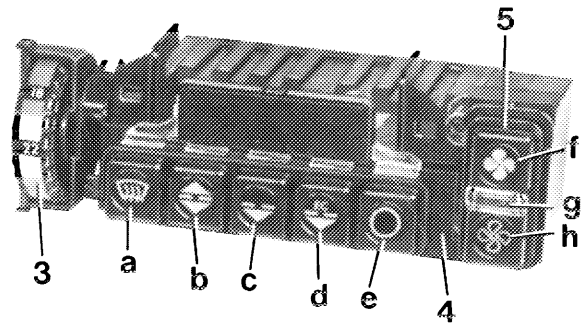

183-17660/1

**Test 12:**

| Selector dial | Function button | Blower  |
|---------------|-----------------|---------|
| 22 °C         | "e"             | "AUTOM" |

- Monovalve closed.
- Recirculating pump not running.
- Compressor switched off.
- Main air flap closed.
- Blower not running.  
Also refer to vacuum function diagram 5 (83–604).

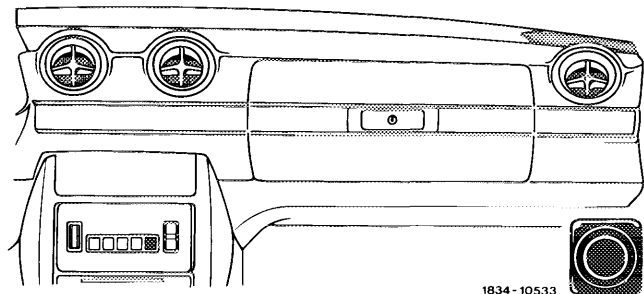

1834-10533

**Test 13:**

Pull coupling from cold engine lock (2).

| Selector dial | Function button | Blower  |
|---------------|-----------------|---------|
| MAX           | "c"             | "AUTOM" |

2 Temperature switch (cold engine lock) engine 102

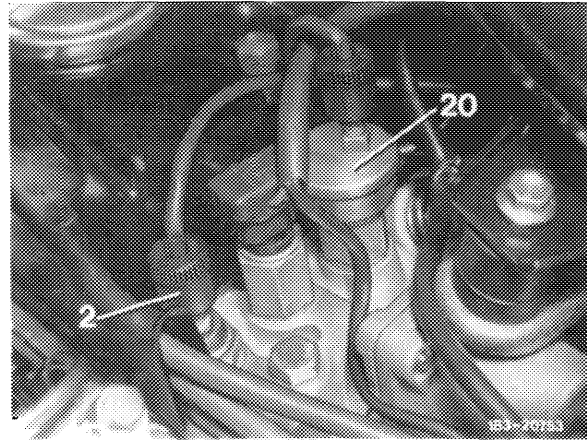

- Main air flap closed.
- Blower not running.

Do not yet plug-on coupling of cold engine lock.

2 Temperature switch (cold engine lock) engine 110

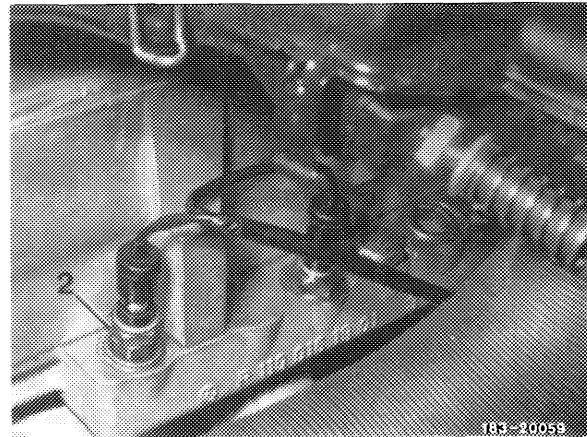

**Test 14:**

| Selector dial | Function button | Blower  |
|---------------|-----------------|---------|
| MIN           | "c"             | "AUTOM" |

2 Temperature switch (cold engine lock) engine 123

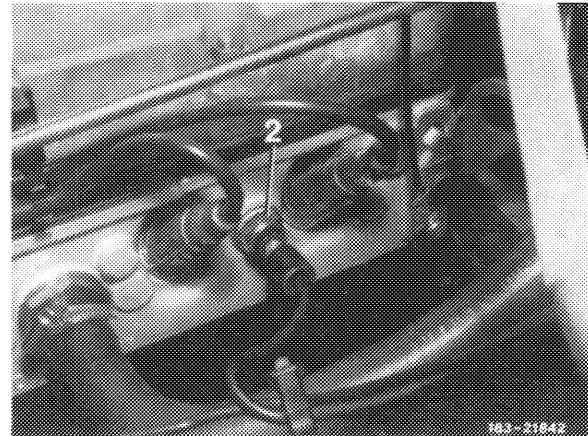

- Main air flap open.
- Fresh air-recirculating air flap in position "recirculating air".
- Blower starts after approx. 10 seconds (5 V to 10 V or 2nd stage to 5th stage).
- Plug-in coupling of cold engine lock.

For all tests, also refer to electric wiring diagrams.

2 Temperature switch (cold engine lock) diesel engines

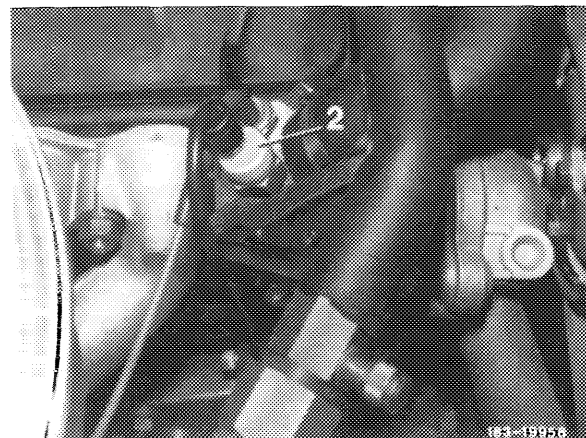

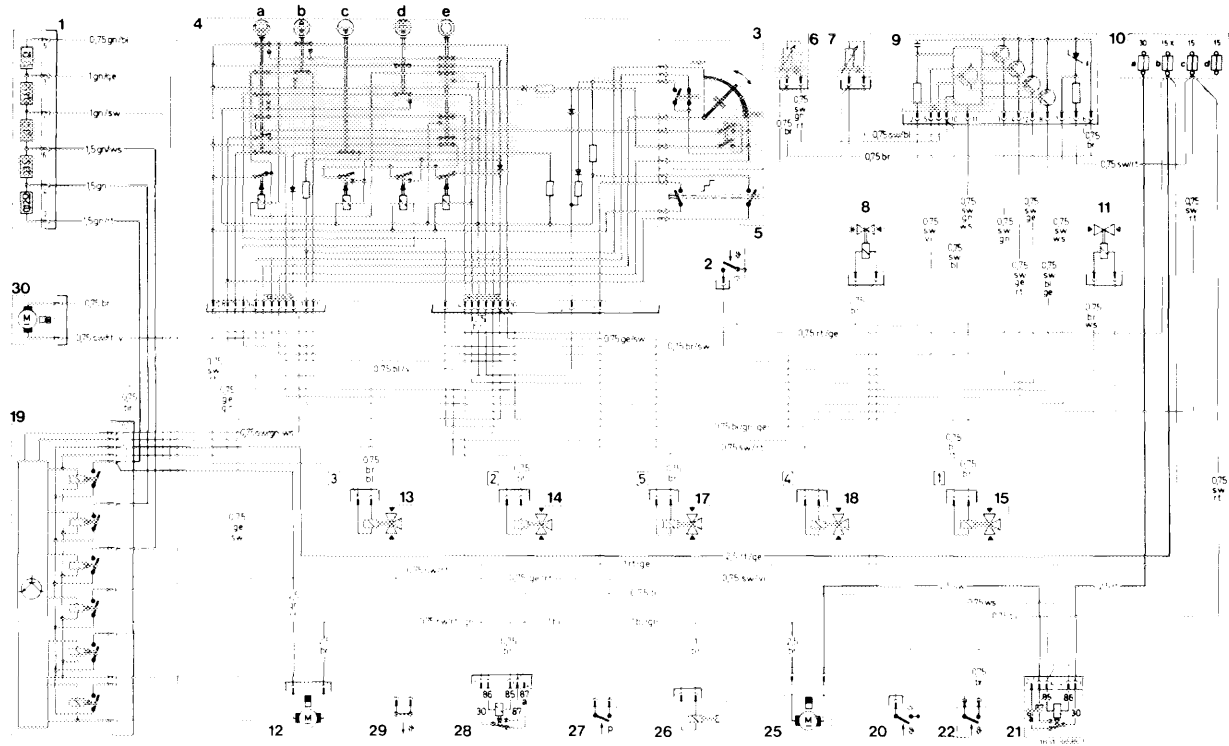

Electric wiring diagram automatic climate control  
Model 123.0, 123.1

- |    |   |    |   |
|----|---|----|---|
| 1  | Pre-resistance group                                  | 11 | Monovalve   |
| 2  | Temperature switch (cold engine lock)                 | 12 | Blower motor  |
| 3  | Temperature dial                                      | 13 | Switchover valve for center nozzle flap               |
| 4  | Pushbutton switching unit                             | 14 | Switchover valve for legroom flaps                    |
| a  | Defrosting  | 15 | Switchover valve for defroster nozzle flaps           |
| b  | Top and bottom (also legroom)                         | 17 | Switchover valve for main air flap                    |
| c  | Normal adjustment (air conditioning on)               | 18 | Switchover valve for fresh air-recirculating air flap |
| d  | EC (air conditioning off)                             | 19 | Electronic switching unit for blower control          |
| e  | Off   | 20 | Temperature switch 100 °C for additional fan          |
| 5  | Blower switch   | 21 | Relay additional fan (code number 6)                  |
| 6  | Temperature sensor for heat exchanger                 | 22 | Temperature switch 52 °C for additional fan           |
| 7  | In-car temperature sensor                             | 25 | Additional fan  |
| 8  | Switchover valve for rpm stabilization (except 123.1) | 26 | Electromagnetic coupling-refrigerant compressor       |
| 9  | Electronic switching unit for temperature control     | 27 | Low pressure switch refrigerant compressor            |
| 10 | Fusebox   | 28 | Relay refrigerant compressor (code number 12)         |
| a  | Fuse C: 16 amps.                                      | 29 | ETR-switch  |
| b  | Fuse 8: 16 amps.                                      | 30 | Recirculating pump                                    |
| c  | Fuse 14: 8 amps.                                      |    |   |

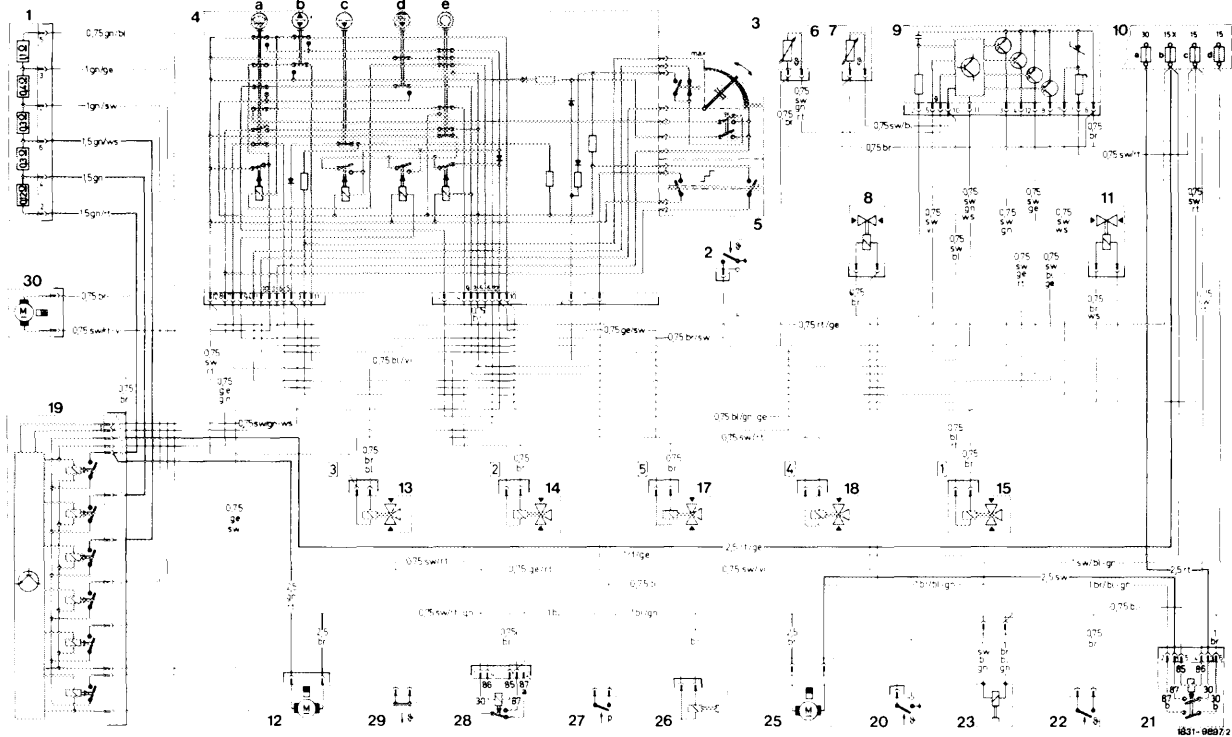

Electric wiring diagram automatic climate control  
Model 123.2

- |   |   |
|---|---|
| 1 Pre-resistance group                              | 11 Monovalve  |
| 2 Temperature switch (cold engine lock)             | 12 Blower motor   |
| 3 Temperature dial                                  | 13 Switchover valve for center nozzle flap                    |
| 4 Pushbutton switching unit                         | 14 Switchover valve for legroom flaps                         |
| a Defrosting  | 15 Switchover valve for defroster nozzle flaps                |
| b Top and bottom (also legroom)                     | 17 Switchover valve for main air flap                         |
| c Normal adjustment (air conditioning on)           | 18 Switchover valve for fresh air-recirculating air flap      |
| d EC (air conditioning off)                         | 19 Electronic switching unit for blower control               |
| e Off   | 20 Temperature switch 100 °C for additional fan               |
| 5 Blower switch                                     | 21 Relay additional fan and magnetic coupling (code number 6) |
| 6 Temperature sensor for heat exchanger             | 22 Temperature switch 52 °C for additional fan                |
| 7 In-car temperature sensor                         | 23 Magnetic coupling for fan                                  |
| 8 Switchover valve for rpm stabilization            | 25 Additional fan   |
| 9 Electronic switching unit for temperature control | 26 Electromagnetic coupling-refrigerant compressor            |
| 10 Fusebox  | 27 Low pressure switch refrigerant compressor                 |
| a Fuse C: 16 amps.                                  | 28 Relay refrigerant compressor (code number 12)              |
| b Fuse 8: 16 amps.                                  | 29 ETR-switch   |
| c Fuse 14: 8 amps.                                  | 30 Recirculating pump   |
| d Fuse 10: 16 amps.                                 |   |