

INDEX

1982 SALES DESIGNATIONS	MODEL
300 D (TURBO)	123.133
300 CD (TURBO)	123.153
300 TD (TURBO)	123.193

INDEX - Alphabetical Listing of Electrical Circuits

	SCHEMATIC	COMPONENT LOCATION		SCHEMATIC	COMPONENT LOCATION
Automatic Antenna	115	202	Lights (continued)		
Automatic Climate Control...	119	310	—License	112,114	203,204
Auxiliary Fan	127	201	—Marker	114	203
Charging System	108	202	—Park	112	204
Cigar Lighter	115	202	—Stop	111	207
Clock	120	208	—Tail	112	204
Cruise Control	111	207	—Trunk	114	203
Engine Overload Protection ..	109	201	—Turn Signal	116	207
Fuse Information	102		Power Distribution	104	204
Gauges	120	208	Power Windows	132	205
Ground Distribution	136		Pre-Glow System	106	205
Heated Seats	134	203	Radio	115	202
Horns	126	203	Rear Defogger	130	205
Lights			Rear Wiper/Washer	129	206
—Backup	109	201	Seat Backrest Locking System	135	206
—Center Console	124	201	Sliding Roof	126	203
—Courtesy	122	203	Start/Stop (Ignition Switch) .	107	206
—Fog Lights	110	203	Transmission Kickdown	109	201
—Glove Box	109	201	Warning Indicators	120	208
—Hazard	116	207	Warning System	118	208
—Headlights	110	203	Wiper/Washer	128	208
—Instrument Cluster	121,124	208			



Fuse-Circuit List

Fuse		Circuits Protected	Page
No.	Amps (color)		
1	8(WT)	Illumination: Instrument Cluster/ Center Console Lights: Marker/License Lights: Park/Tail (RH) Warning System	124 114 112 118
2	8(WT)	Automatic Antenna Clock Courtesy Lights Lights: Hazard Seat Backrest Locking System Trunk Light Warning System	115 121 122 116 135 114 118
3	8(WT)	Lights: Park/Tail (LH)	112
4	8(WT) *16(PK)	Radio Cigar Lighter Glove Box Light *With Heated Seats (Front)	115 115 109 134
5		NOT USED	
6	16(PK)	Headlights Rear Wiper/Washer (TD only) Wiper/Washer	110 129 128
7	8(WT)	Headlights (RH High Beam)	110
8	16 (PK)	Automatic Climate Control	119

Fuse		Circuits Protected	Page
No.	Amps (color)		
9	8(WT)	Headlight (LH High Beam)	110
10	16(PK) *25(BU)	Rear Defogger (D & CD Only) Rear Defogger (TD Only) *With Heated Seats (Rear)	130 131 134
11	16(PK)	Headlights (RH Low Beam)/Fog Lights	110
12	8(WT)	Auxiliary Fan Lights: Turn Signal Power Windows Stoplights/Cruise Control Warning Indicators/Gauges	127 116 132 111 120
13	8(WT)	Headlights (LH Low Beam)	110
14	8(WT)	Automatic Climate Control Backup Lights/Transmission Kickdown Engine Overload Protection Horns Warning System	119 109 126 118
a	16(PK)	Power Windows (RF/LR)	132
b	16(PK)	Power Windows (LF/RR)	132
c	16(PK)	Auxiliary Fan	127
d	16(PK)	Sliding Roof	126
In-Line	80	Pre-Glow System (Part of Glow Plug Control Relay)	106

102
300
D/CD/TD
TURBO

FUSE BOX

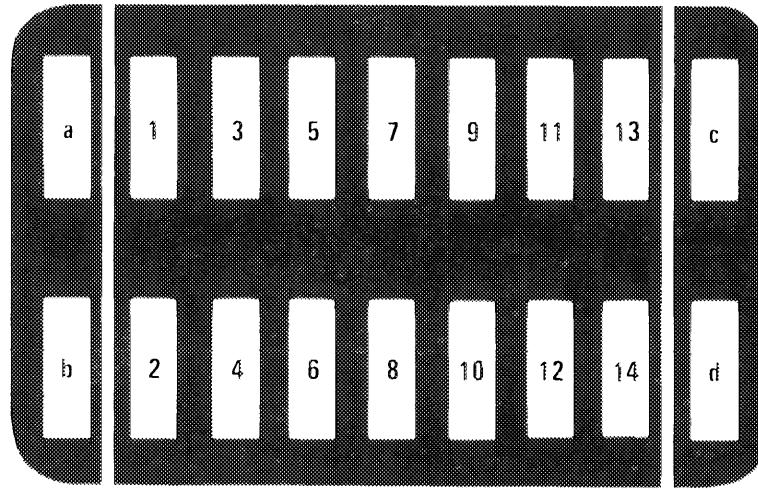

103
300
D/CD/TD
TURBO

RELAY CODE	RELAY USE
6	Auxiliary Fan Relay
10	Window Relay

POWER DISTRIBUTION

(For Component Locations See Page 204)

104
300
D/CD/TD
TURBO

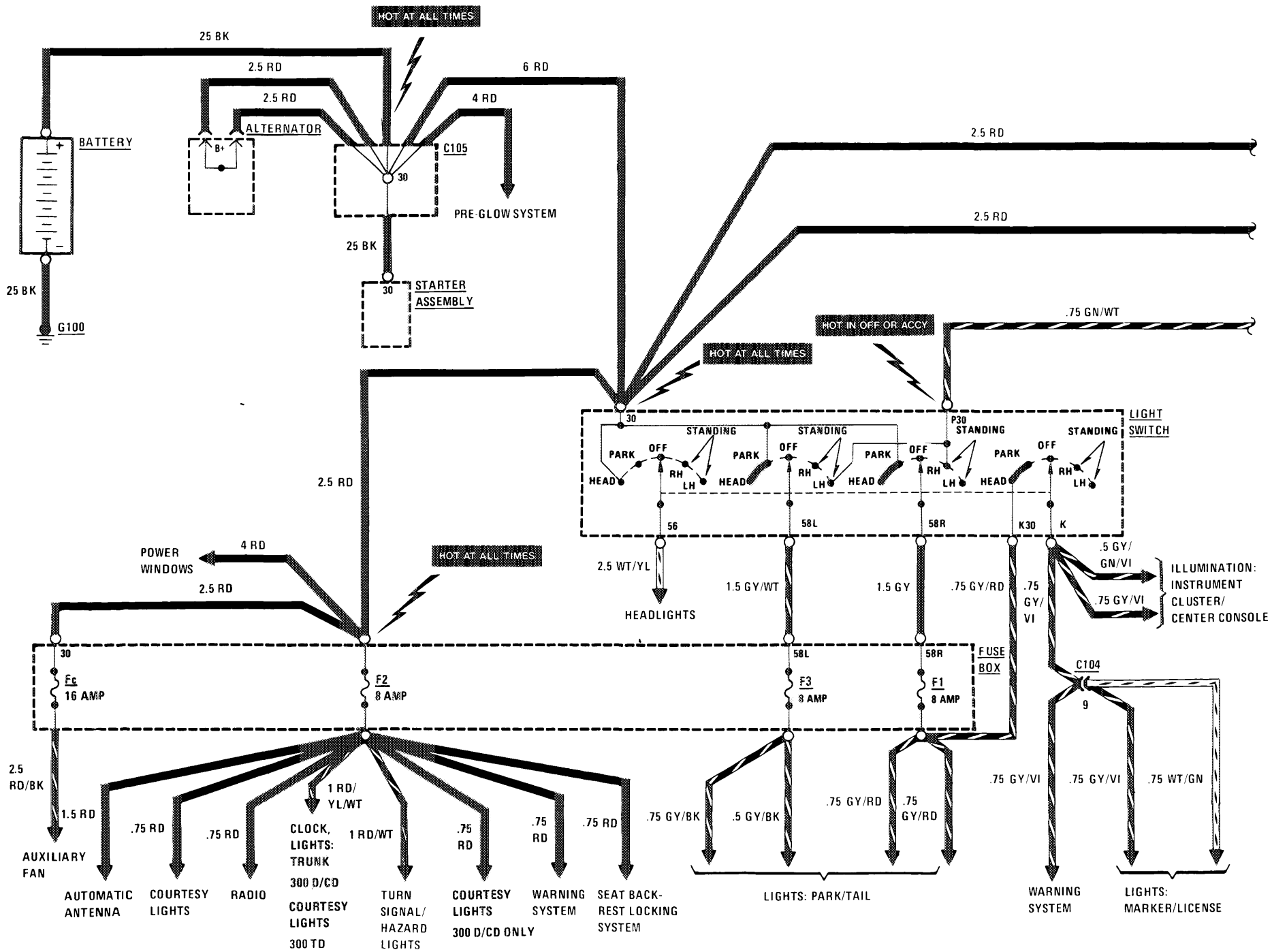

POWER DISTRIBUTION

(For Component Locations See Page 204)

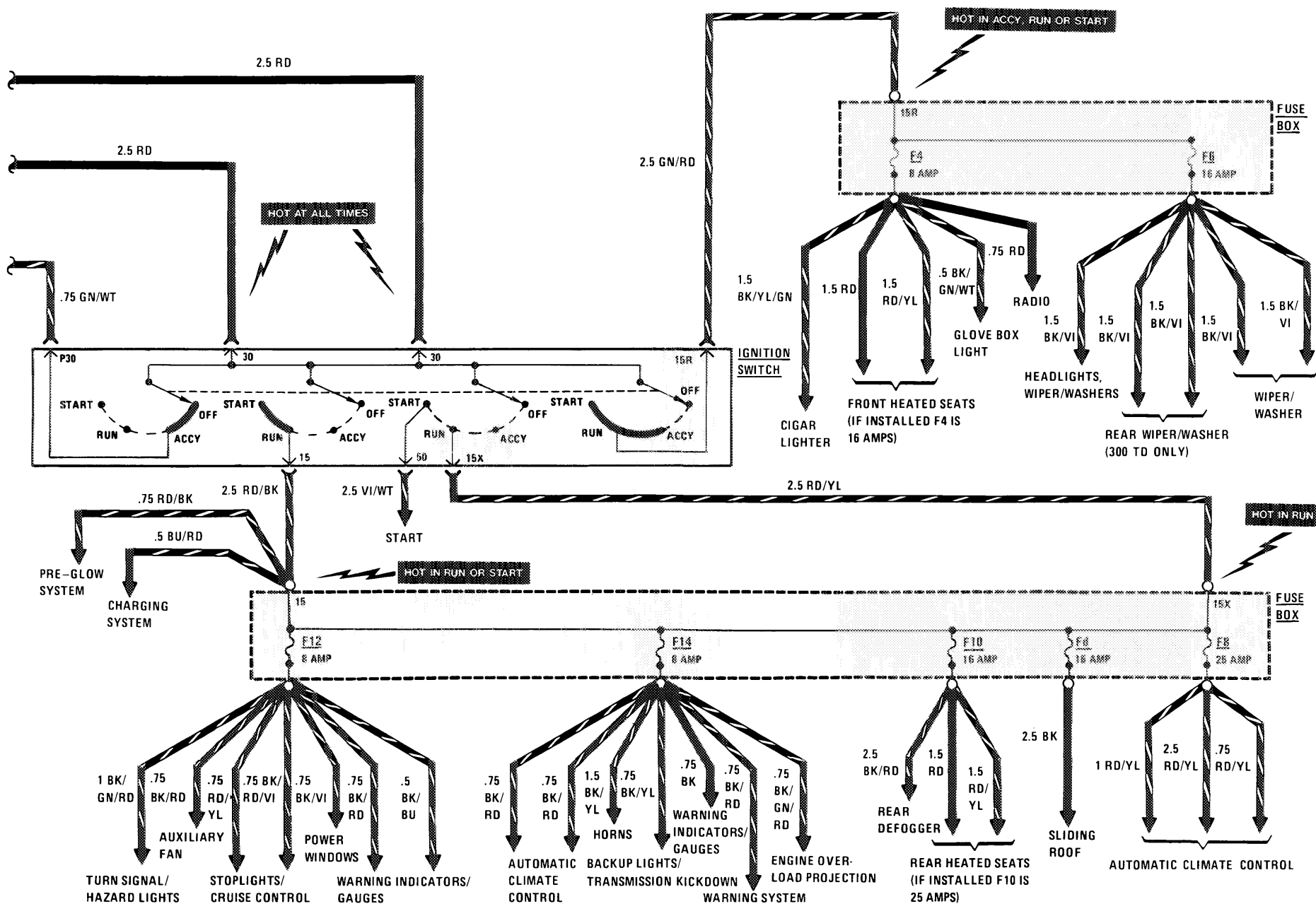

105
300
D/CD/TD
TURBO

PRE-GLOW SYSTEM

(For Component Locations See Page 205)

106
300
D/CD/TD
TURBO

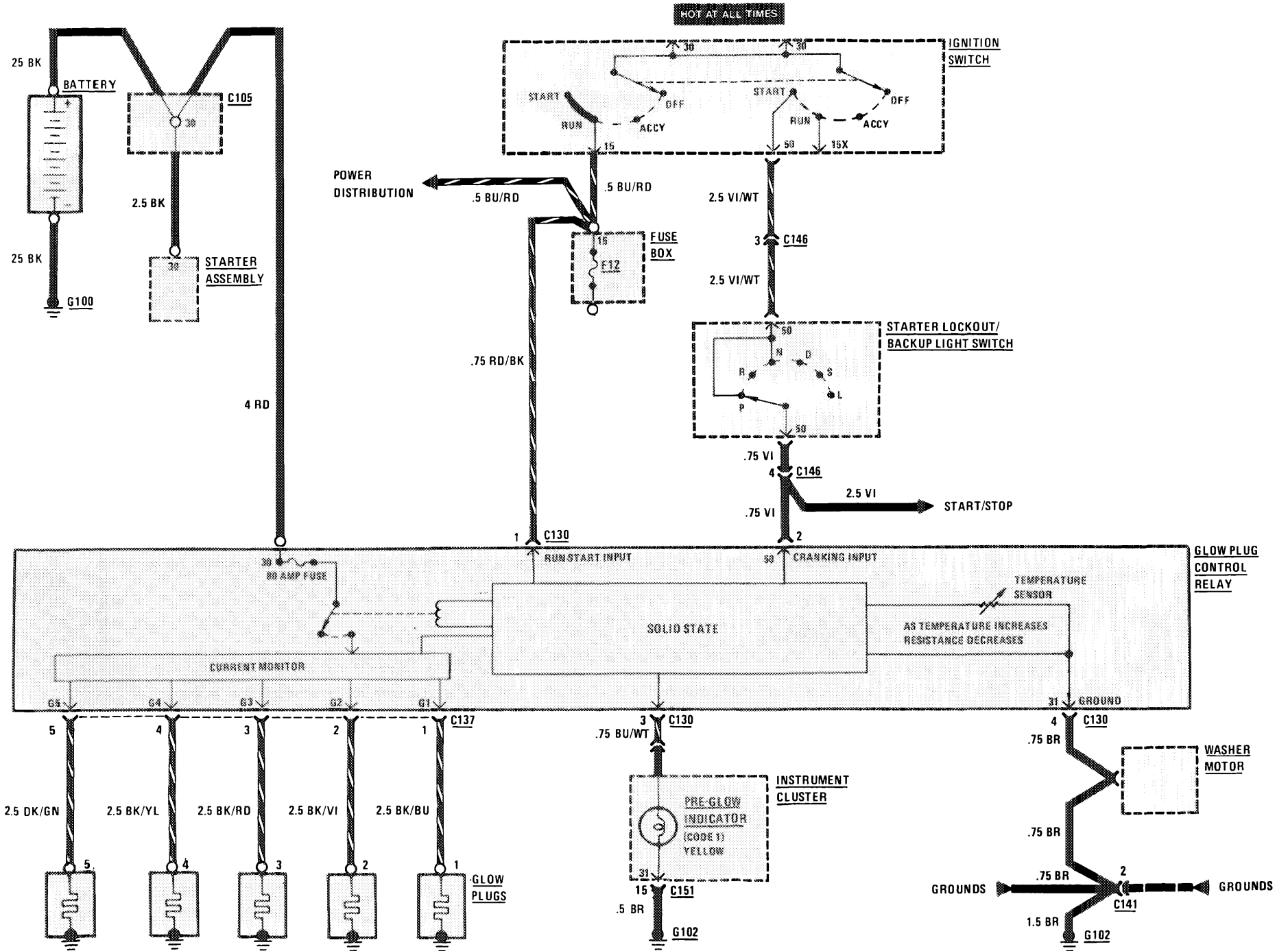

START/STOP (IGNITION SWITCH)

(For Component Locations See Page 206)

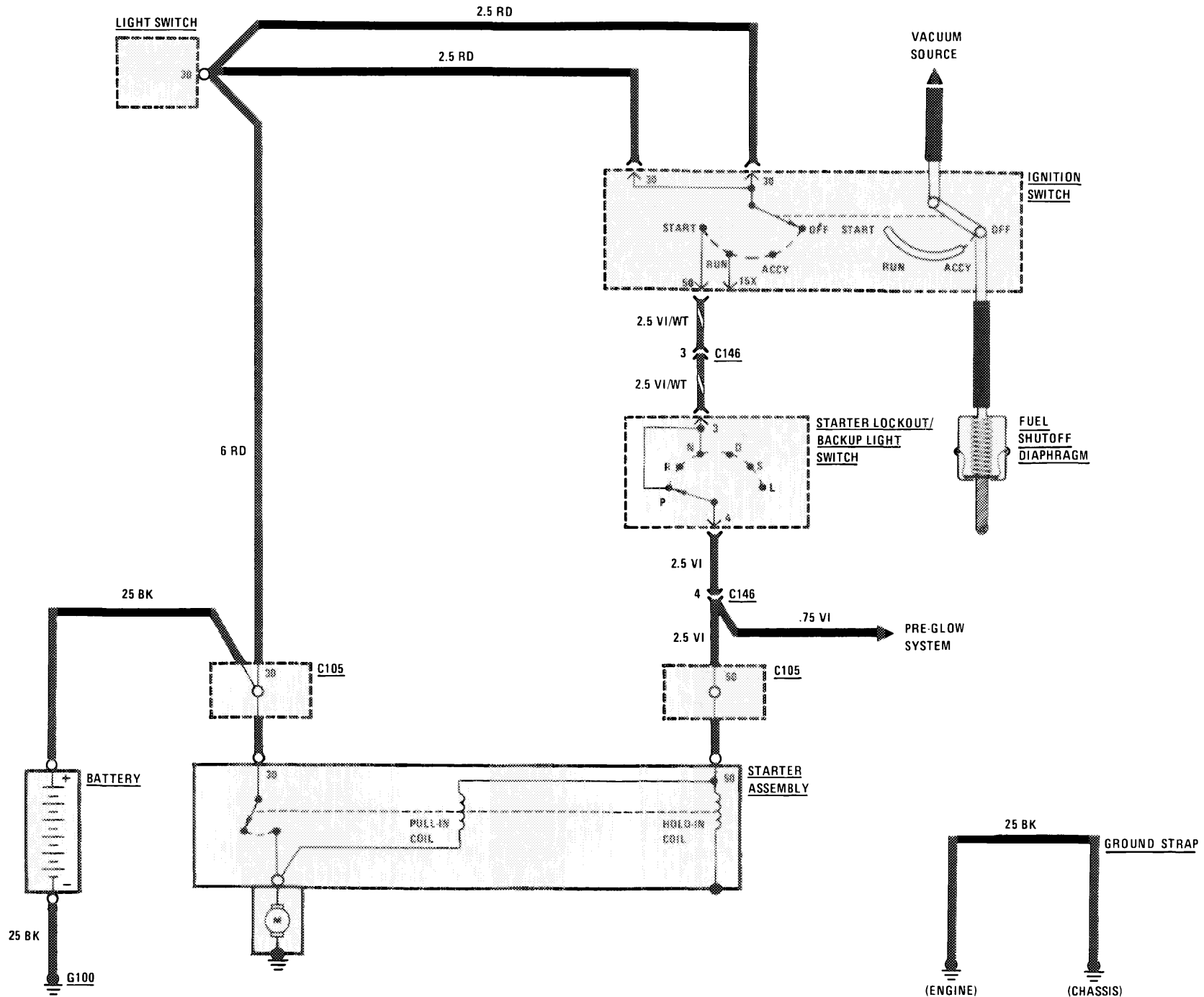

CHARGING SYSTEM

(For Component Locations See Page 202)

108
300
D/CD/TO
TURBO

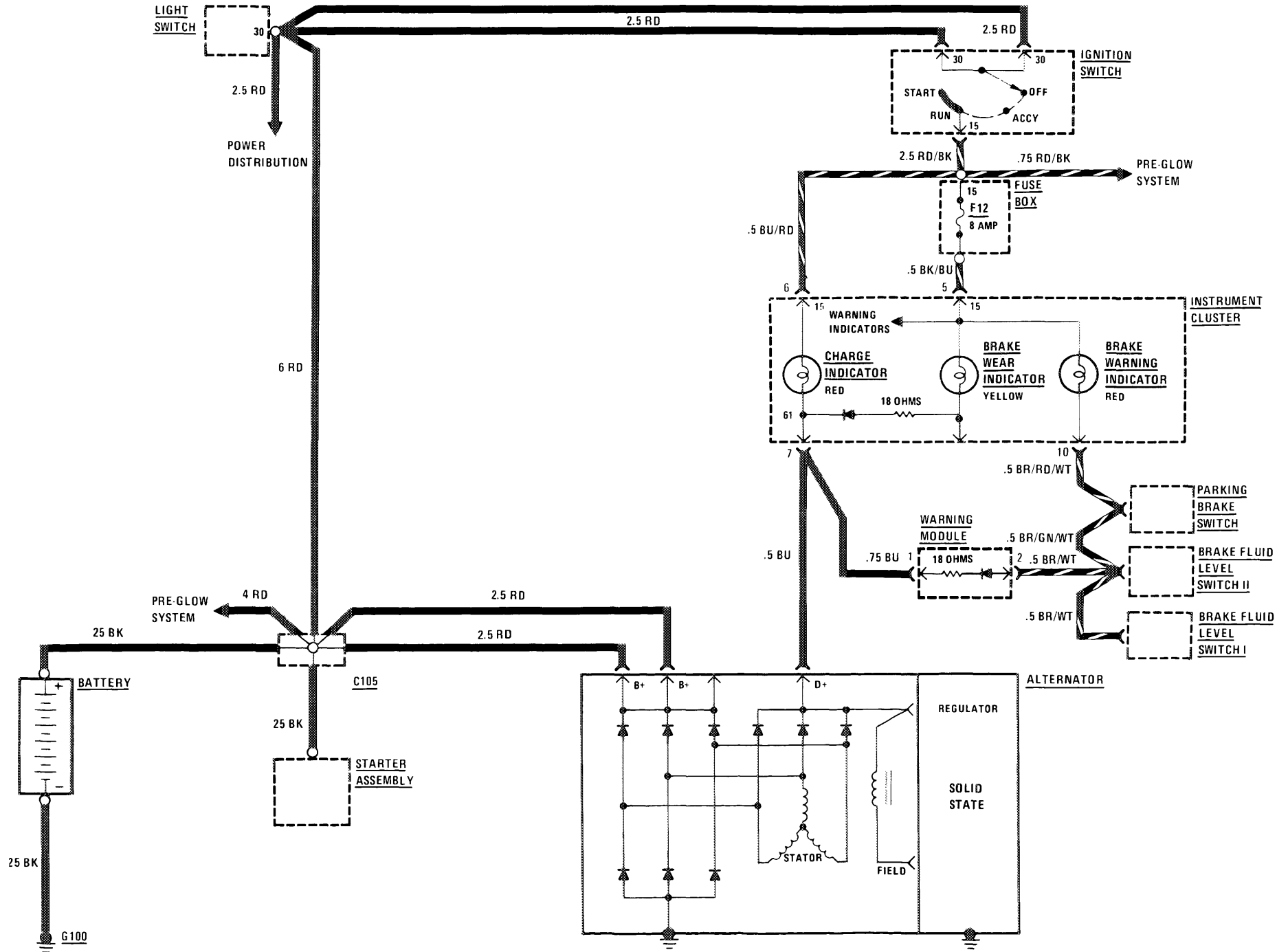

TRANSMISSION KICKDOWN/BACKUP LIGHTS

GLOVE BOX LIGHT

(For Component Locations See Page 201)

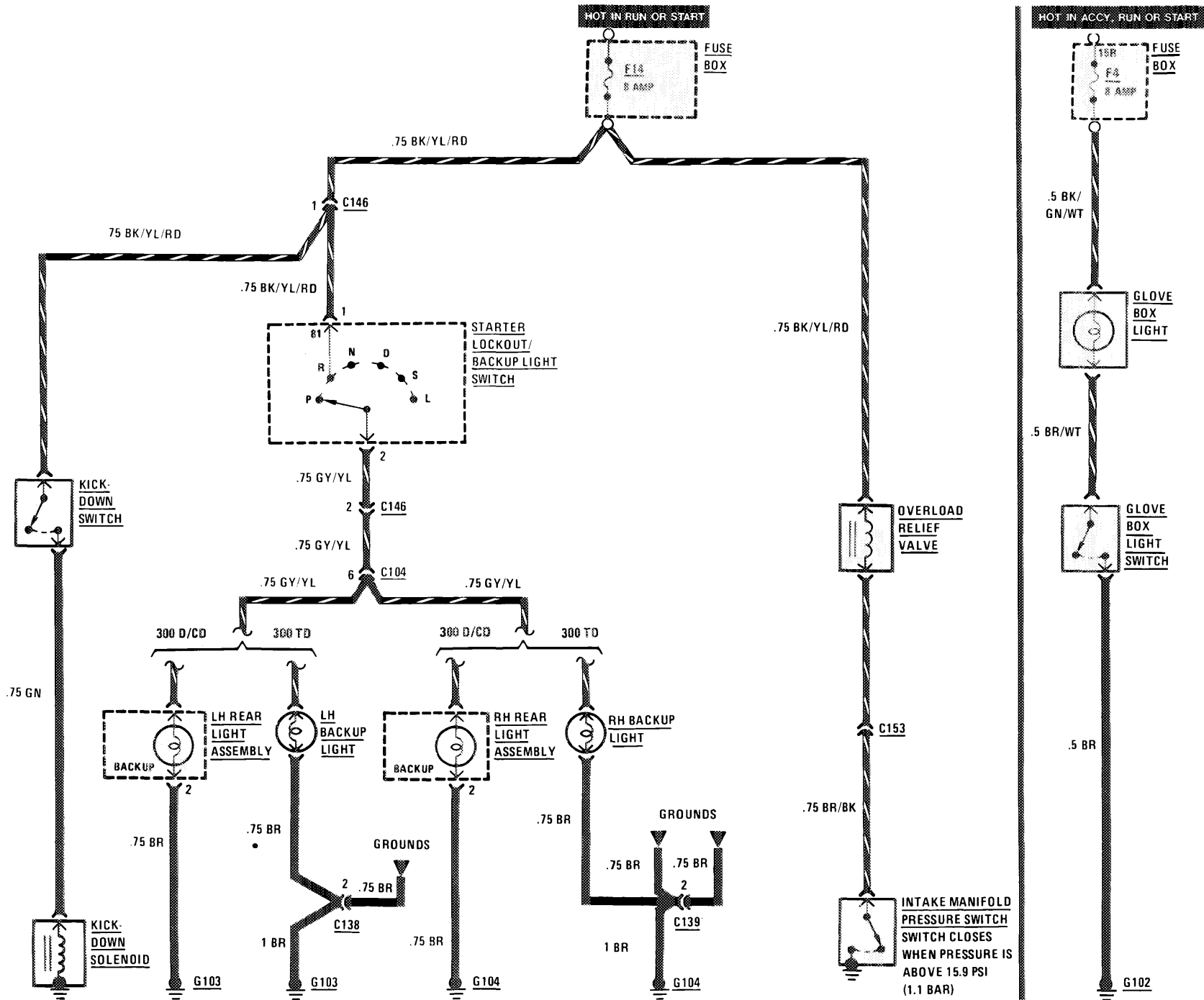

HEADLIGHTS/FOG LIGHTS

(For Component Locations See Page 203)

110
300
D/CO/TO
TURBO

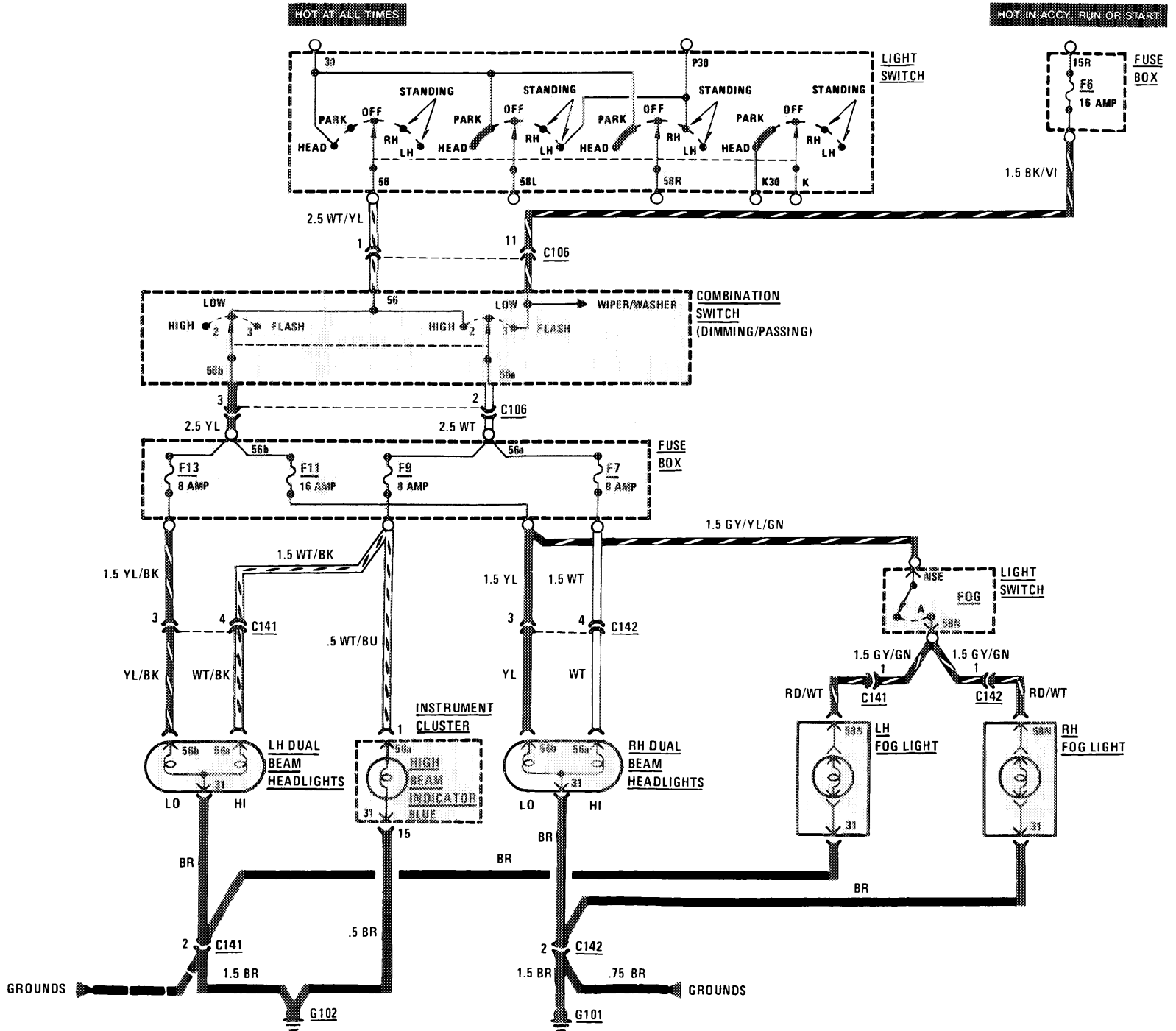

STOPLIGHTS/CRUISE CONTROL

(For Component Locations See Page 207)

300 TD

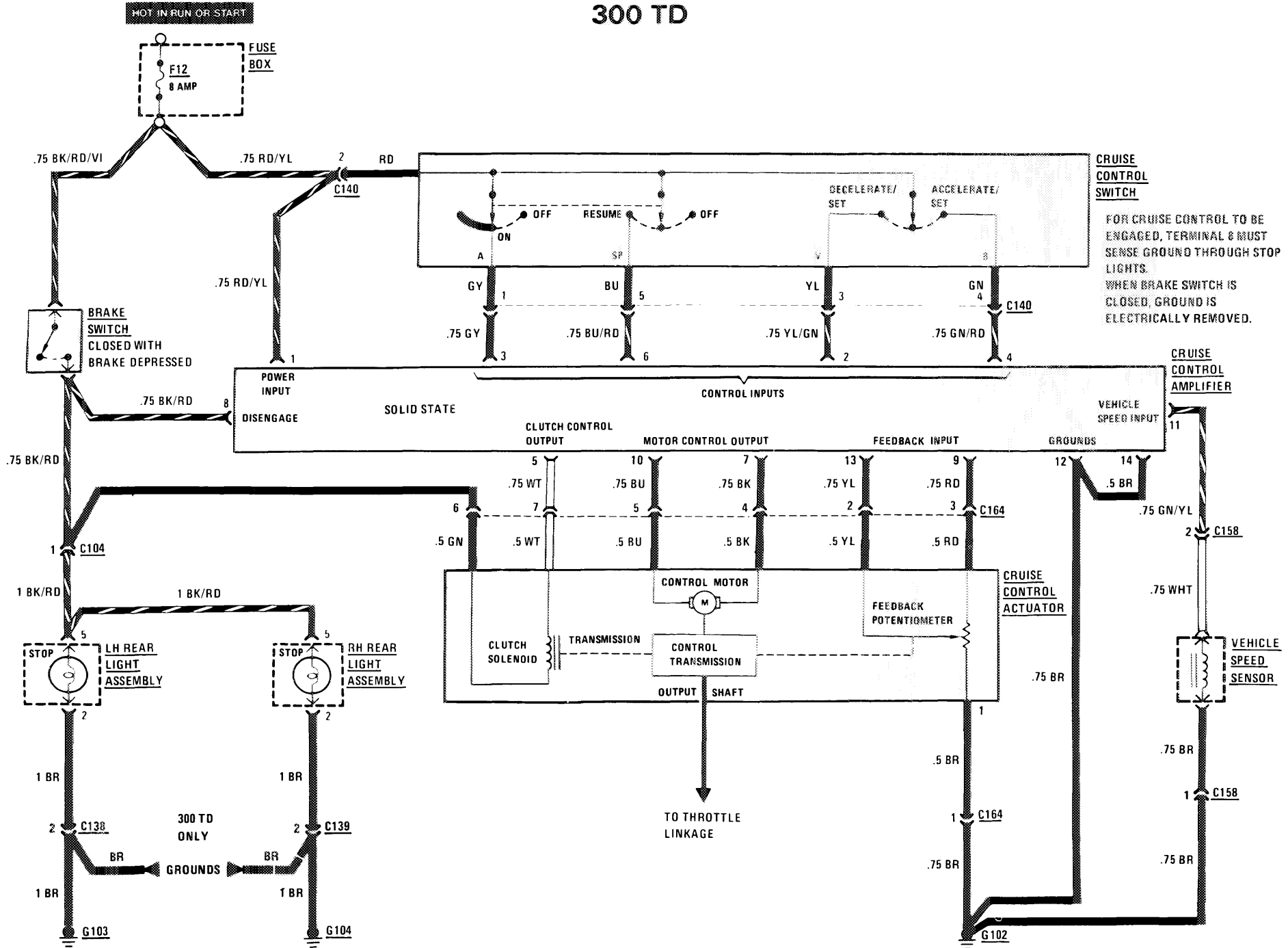

111
300
D/CD/TD
TURBO

LIGHTS: PARK/TAIL/LICENSE

(For Component Locations See Page 204)

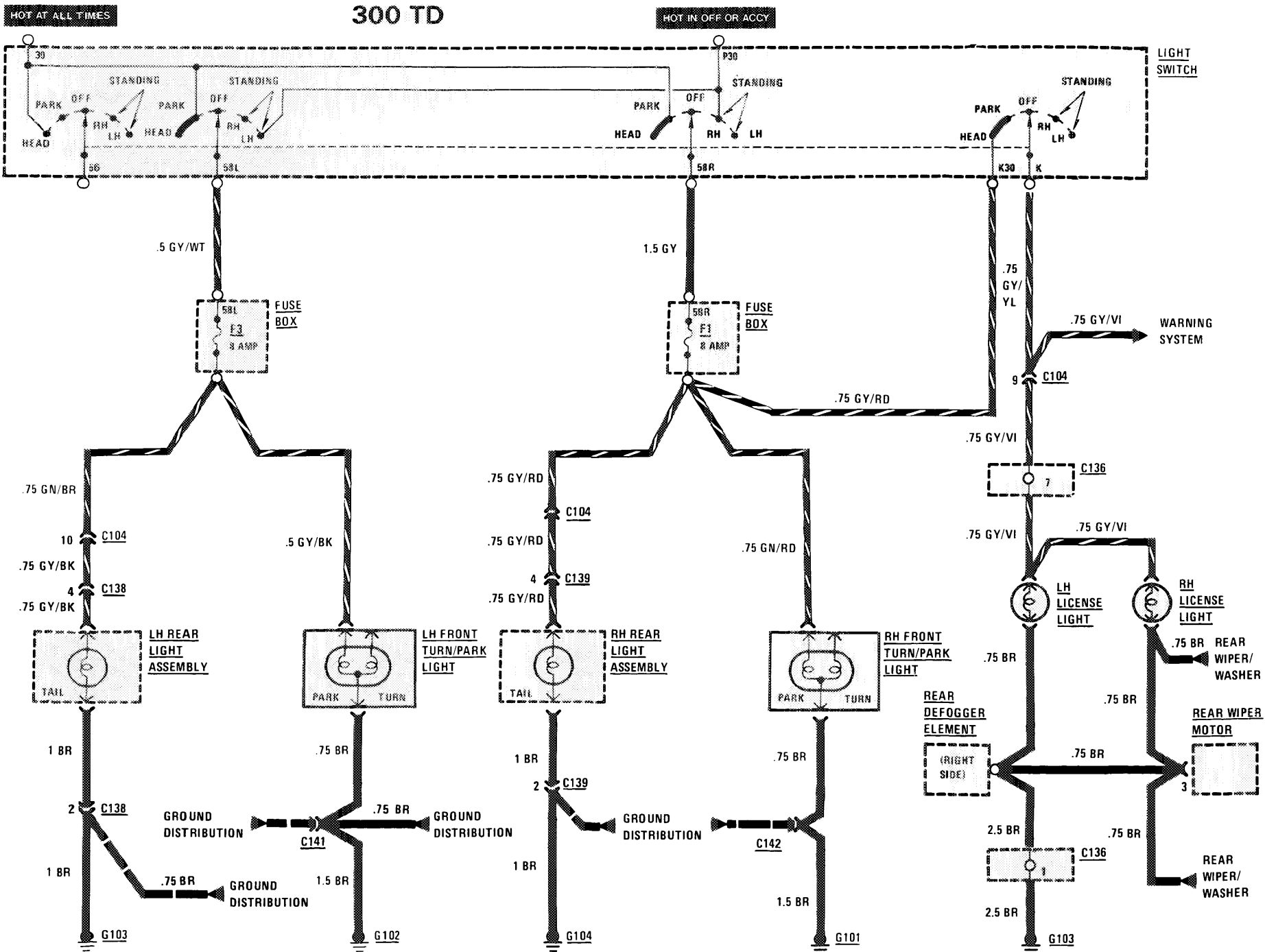

112
300
D/CO/TD
TURBO

LIGHTS: PARK/TAIL

(For Component Locations See Page 204)

HOT AT ALL TIMES

300 D/CD

HOT IN OFF OR ACCY

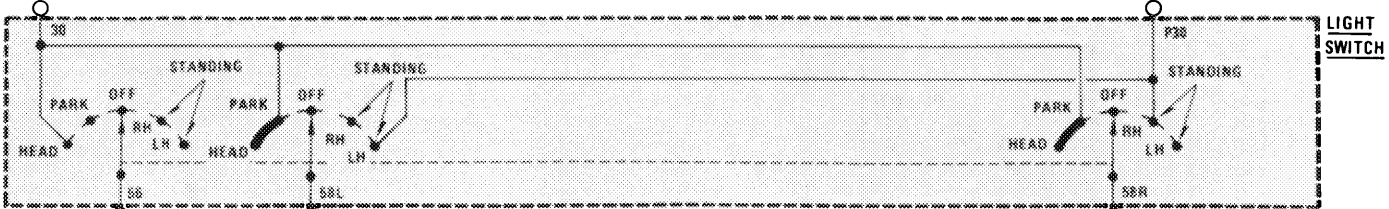

1.5 GY/WT

1.5 GY

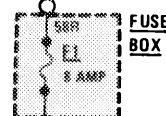
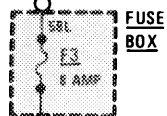

.75 GY/BK

10

C104

.75 GY/BK

6



.75 BR

G103

.5 GY/BK

4

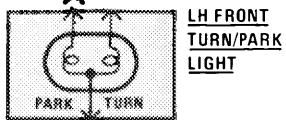

.75 BR

G102

GROUND

.75 BR

2

C141

GROUND

1.5 BR

.75 GY/RD

12

C104

.75 GY/RD

6

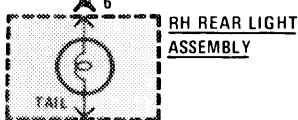

.75 BR

G104

.75 GY/RD

4

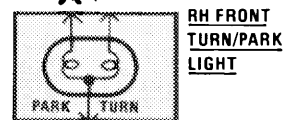

.75 BR

G101

GROUND

.75 BR

2

C142

GROUND

.75 GY/RD

113
300
D/CD/TD
TURBO

LIGHTS: MARKER/LICENSE/TRUNK

(For Component Locations See Page 203)

300 D/CD

114
300
D/CD/TO
TURBO

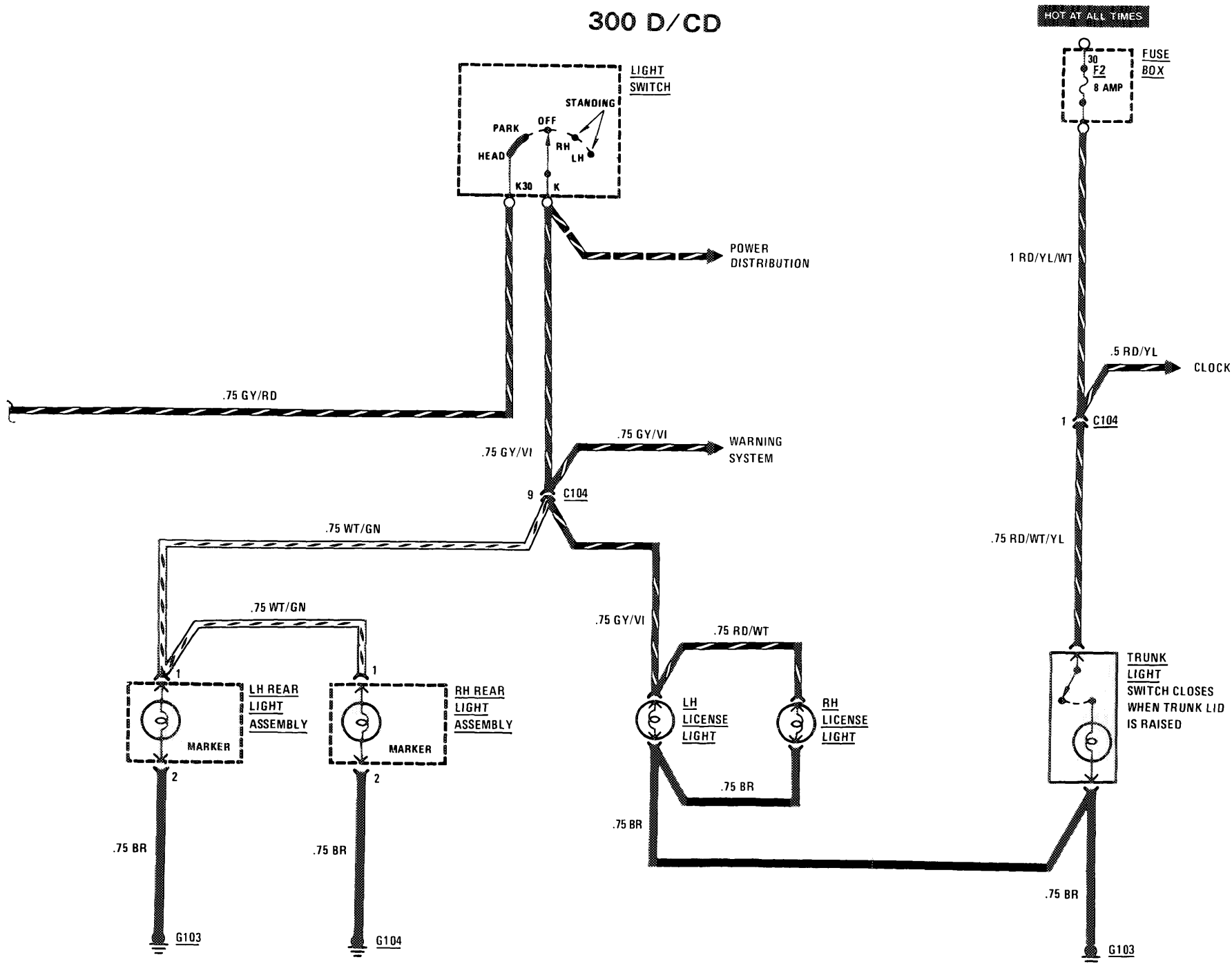

CIGAR LIGHTER/RADIO/AUTOMATIC ANTENNA

(For Component Locations See Page 202)

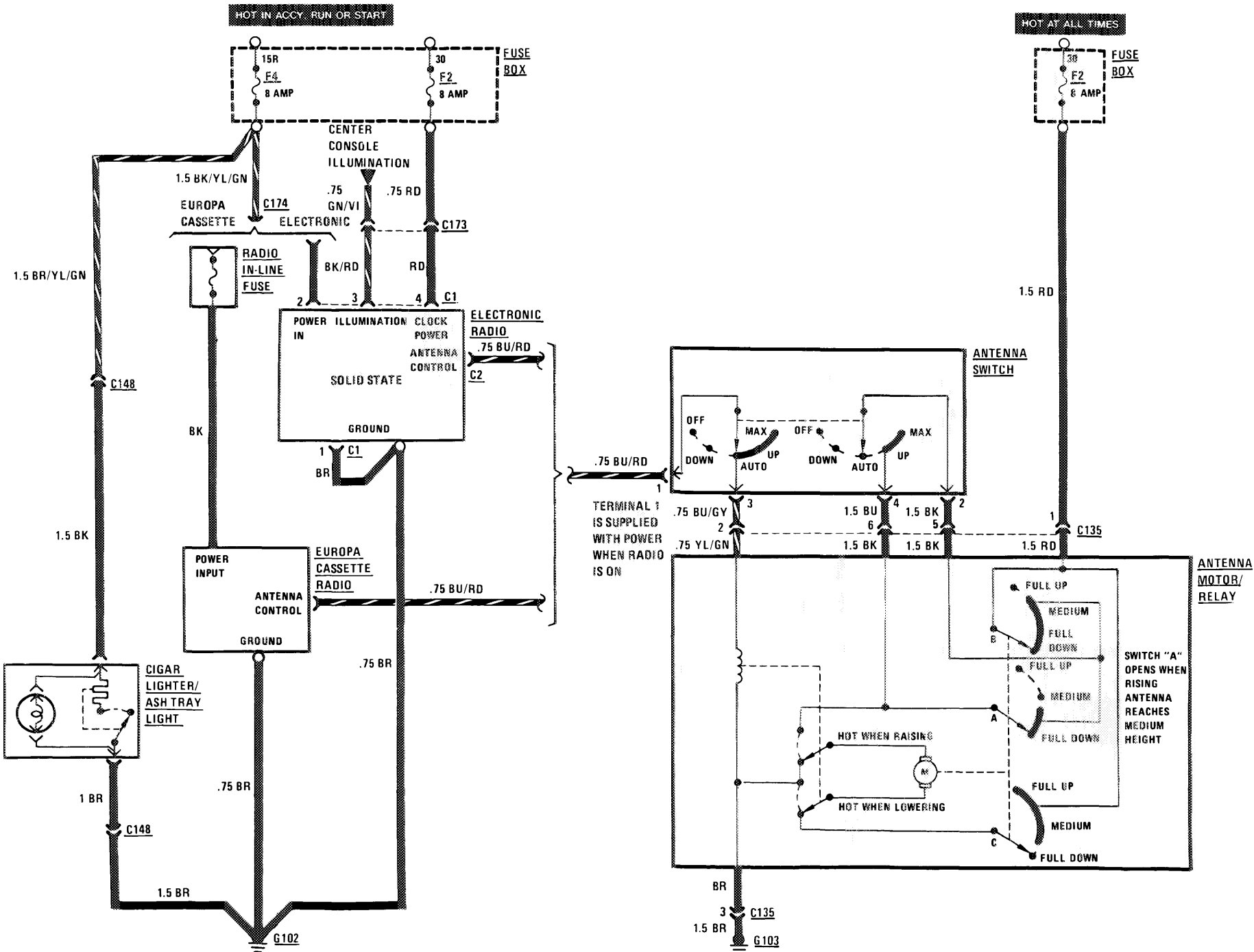

115
 300
 D/CD/TO
 TURBO

TURN SIGNAL/HAZARD LIGHTS

(For Component Locations See Page 207)

116
300
Q/CD/TD
TURBO

300 D/CD

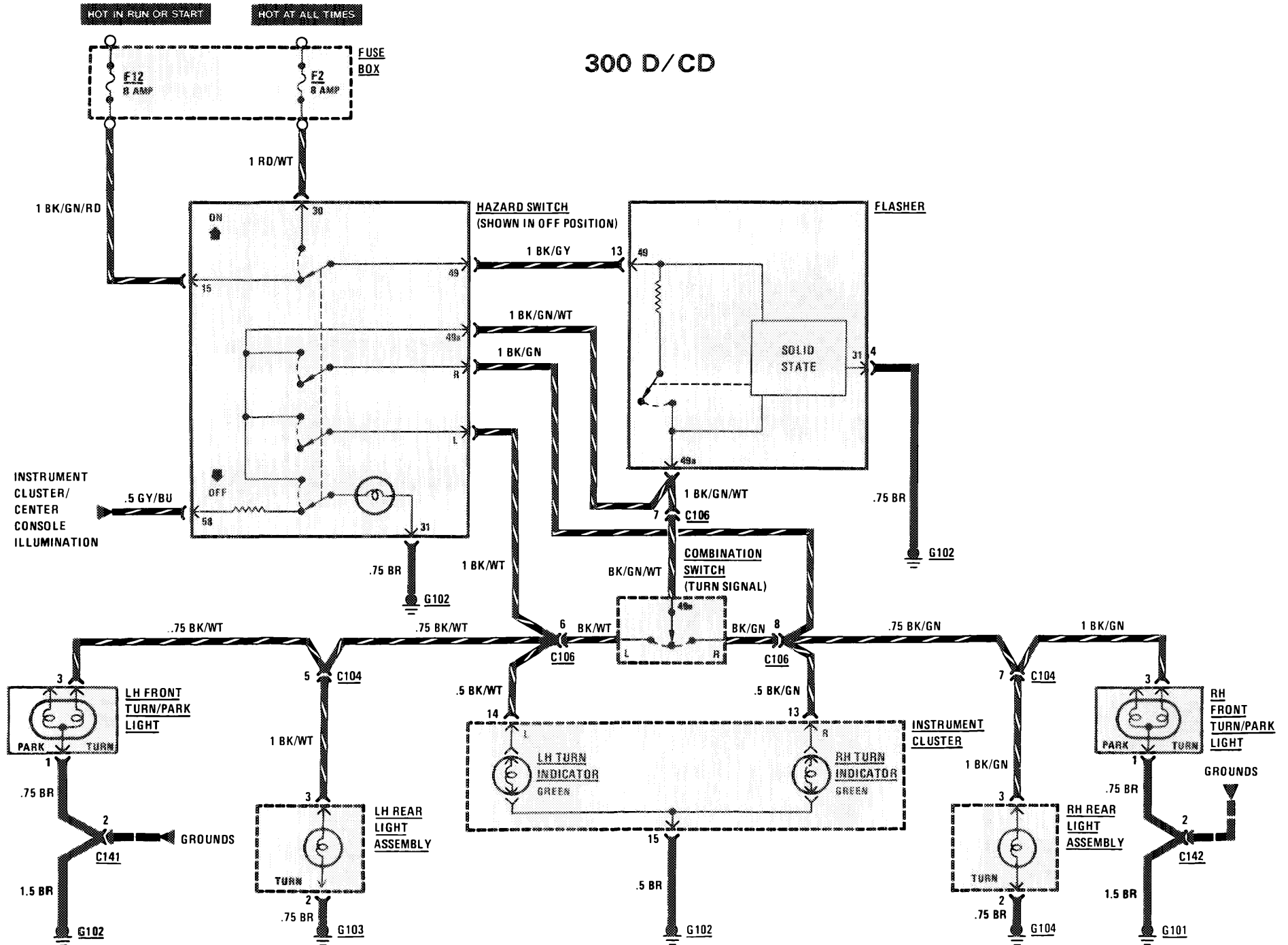

TURN SIGNAL/HAZARD LIGHTS

(For Component Locations See Page 207)

300 TD

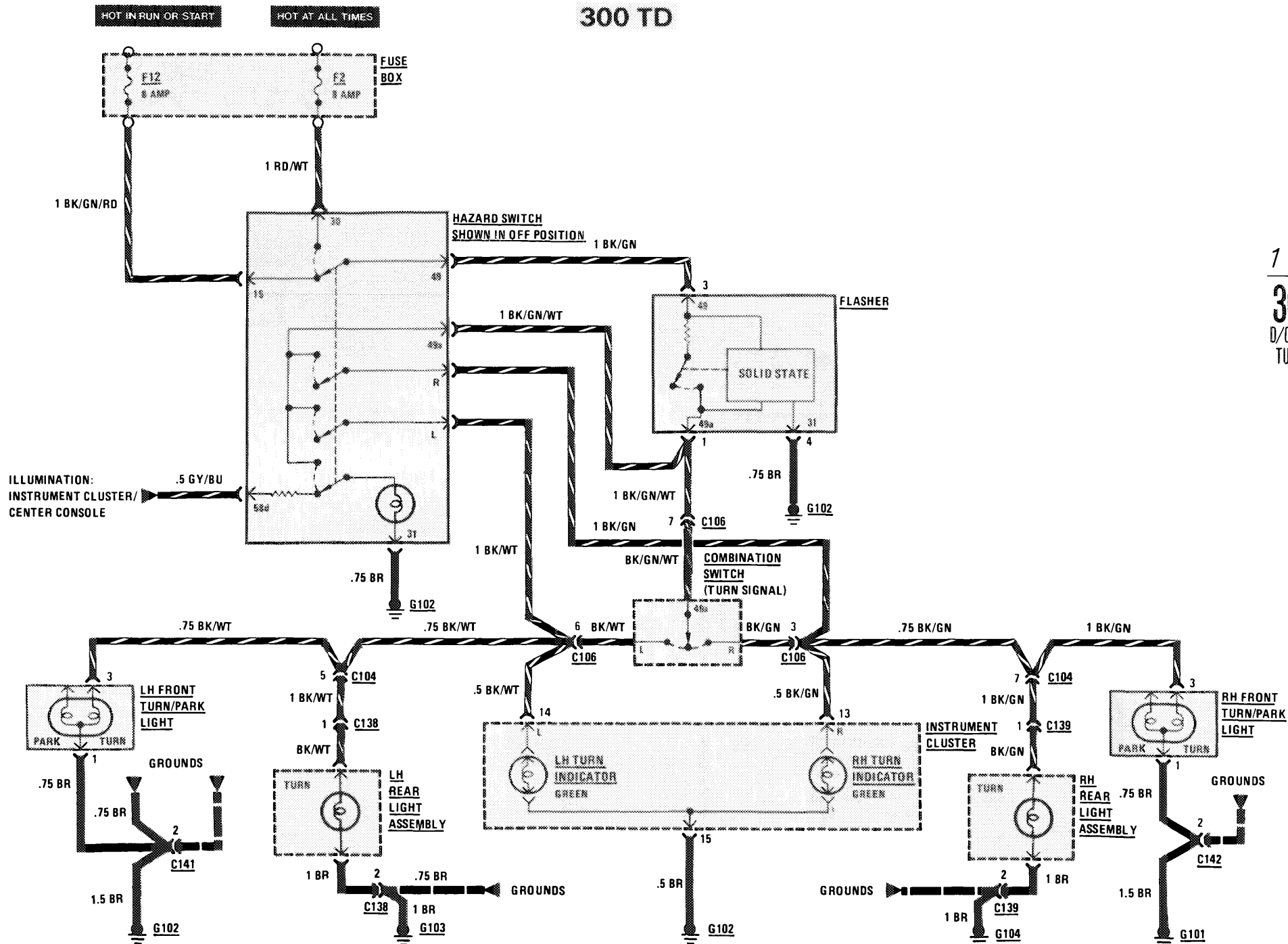

117
300
D/CD/TD
TURBO

WARNING SYSTEM

(For Component Locations See Page 208)

118
300
D/CD/TD
TURBO

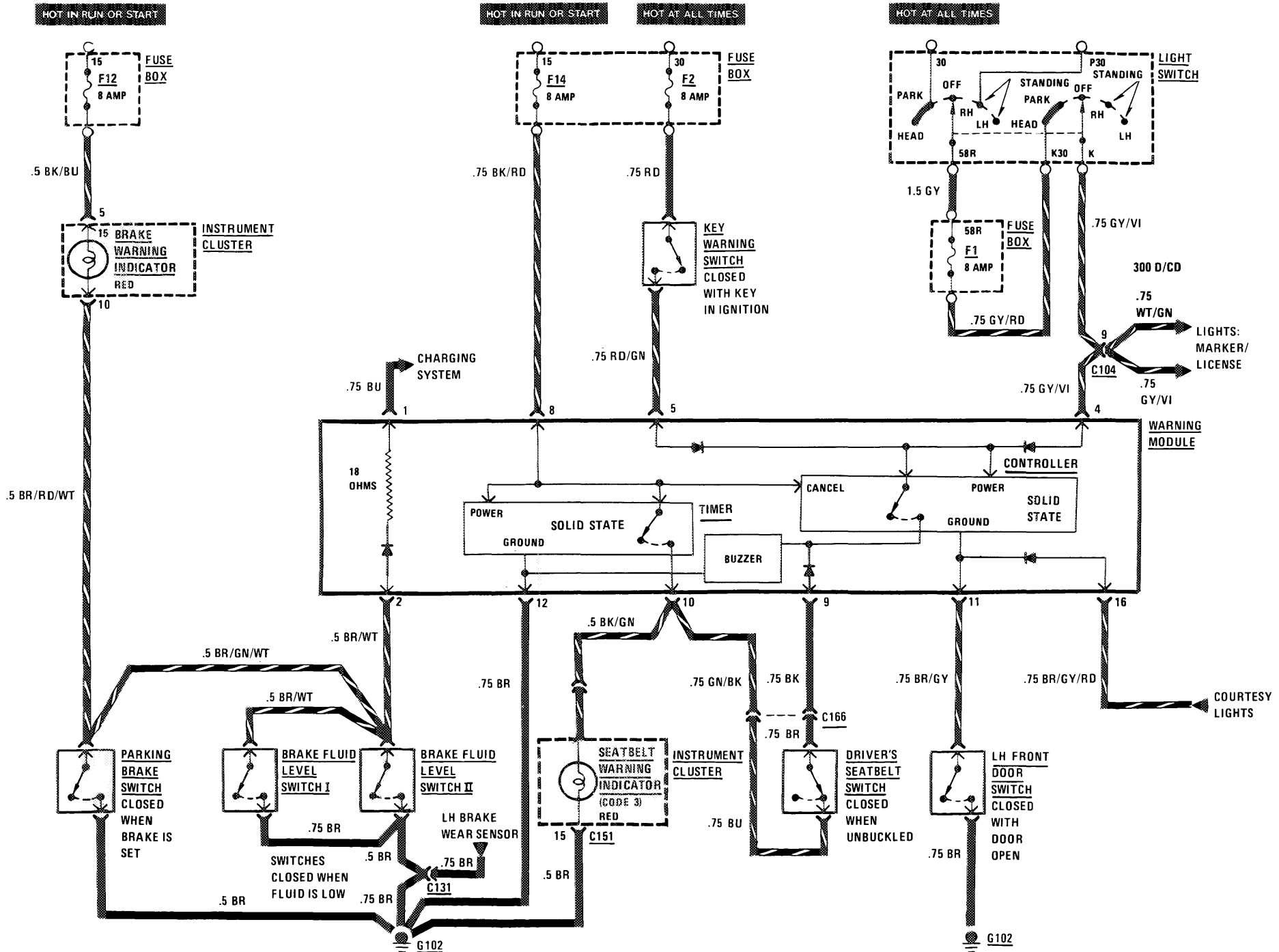

AUTOMATIC CLIMATE CONTROL (ACC) POWER AND GROUND DISTRIBUTION

(For Component Locations See Page 310)

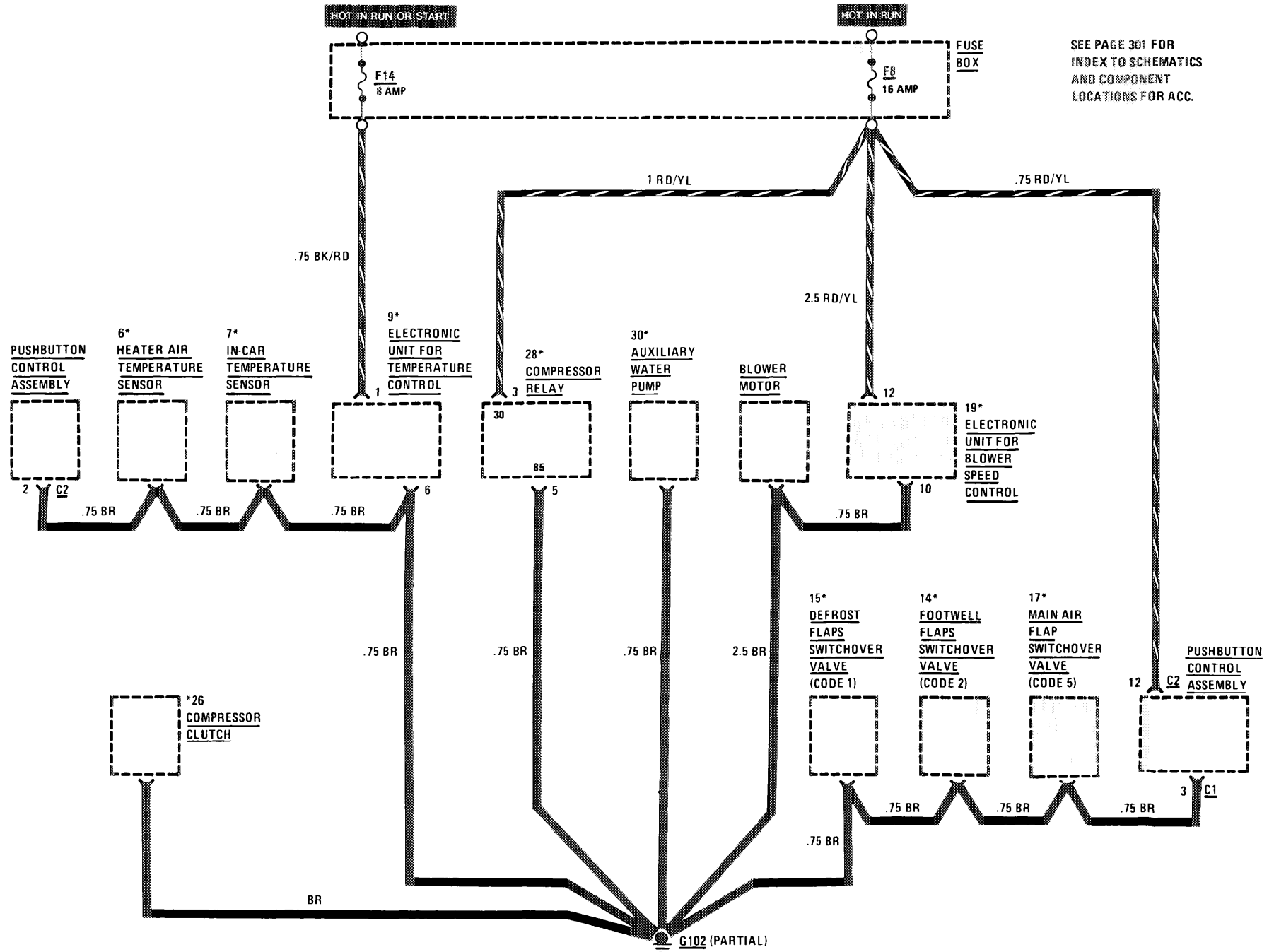

SEE PAGE 361 FOR INDEX TO SCHEMATICS AND COMPONENT LOCATIONS FOR ACC.

WARNING INDICATORS/GAUGES

(For Component Locations See Page 208)

120
300
D/CD/TD
TURBO

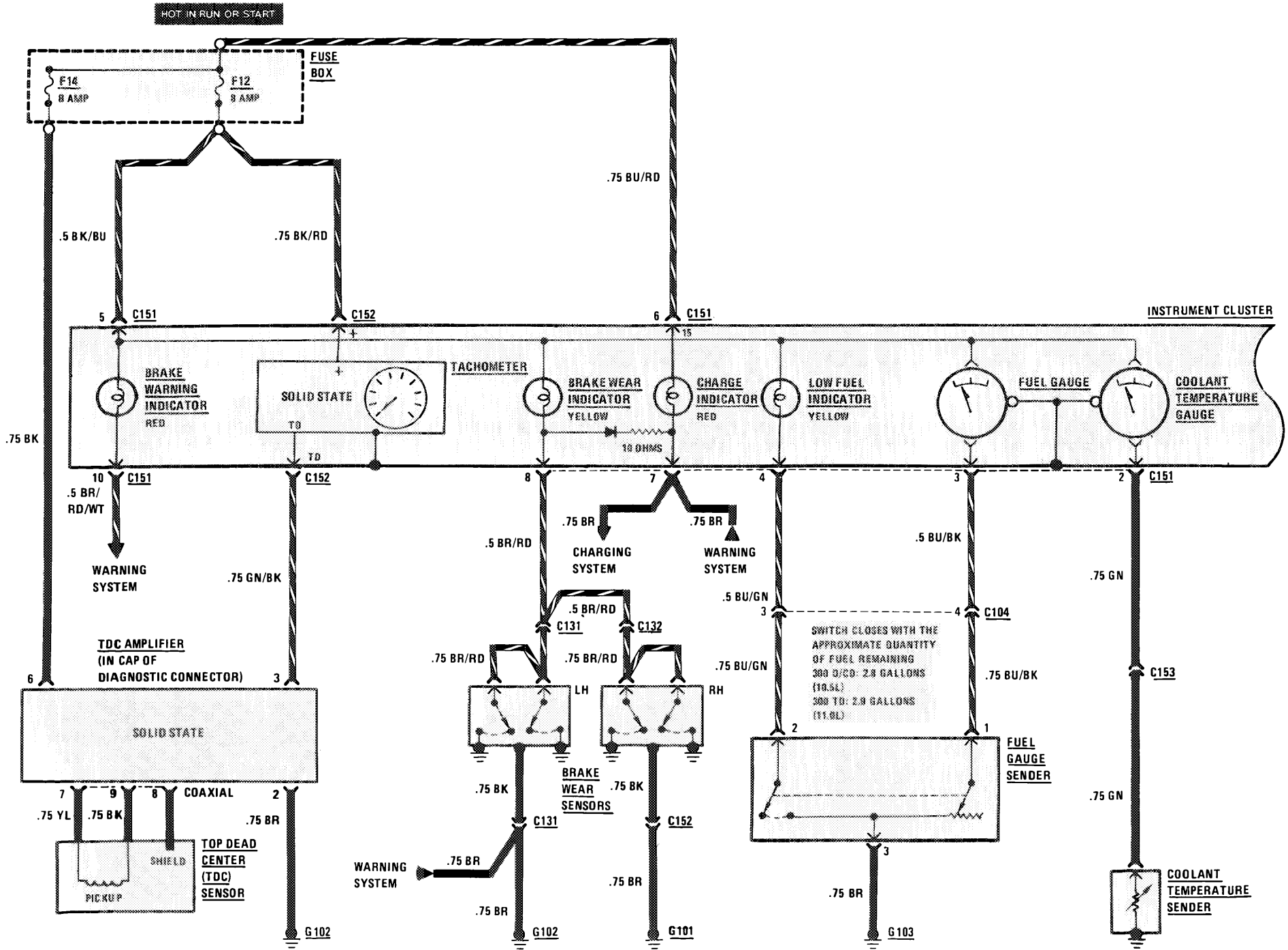

WARNING INDICATORS/GAUGES/CLOCK/INSTRUMENT CLUSTER ILLUMINATION

(For Component Locations See Page 208)

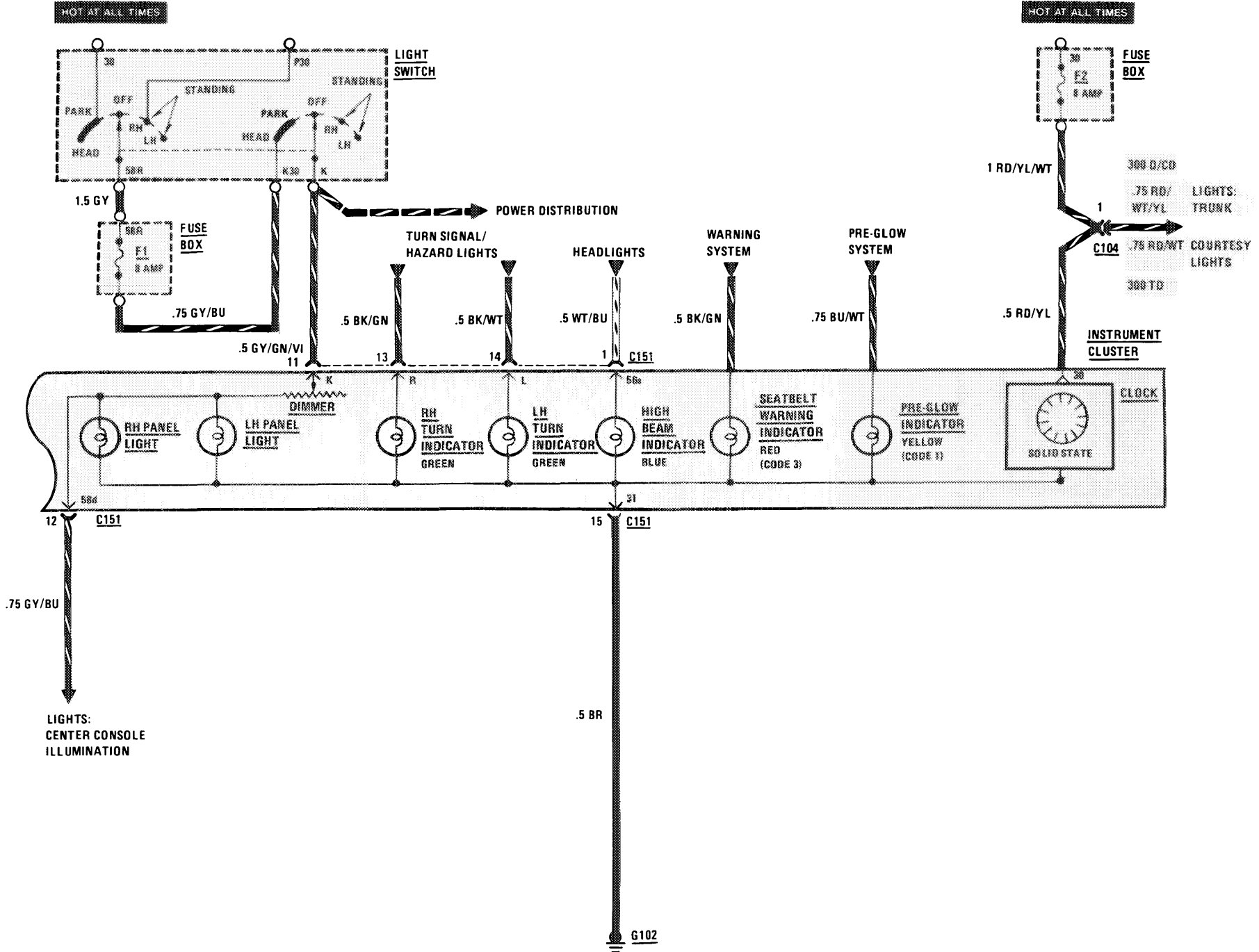

COURTESY LIGHTS

(For Component Locations See Page 202)

300 D/CD

122
300
D/CD/TD
TURBO

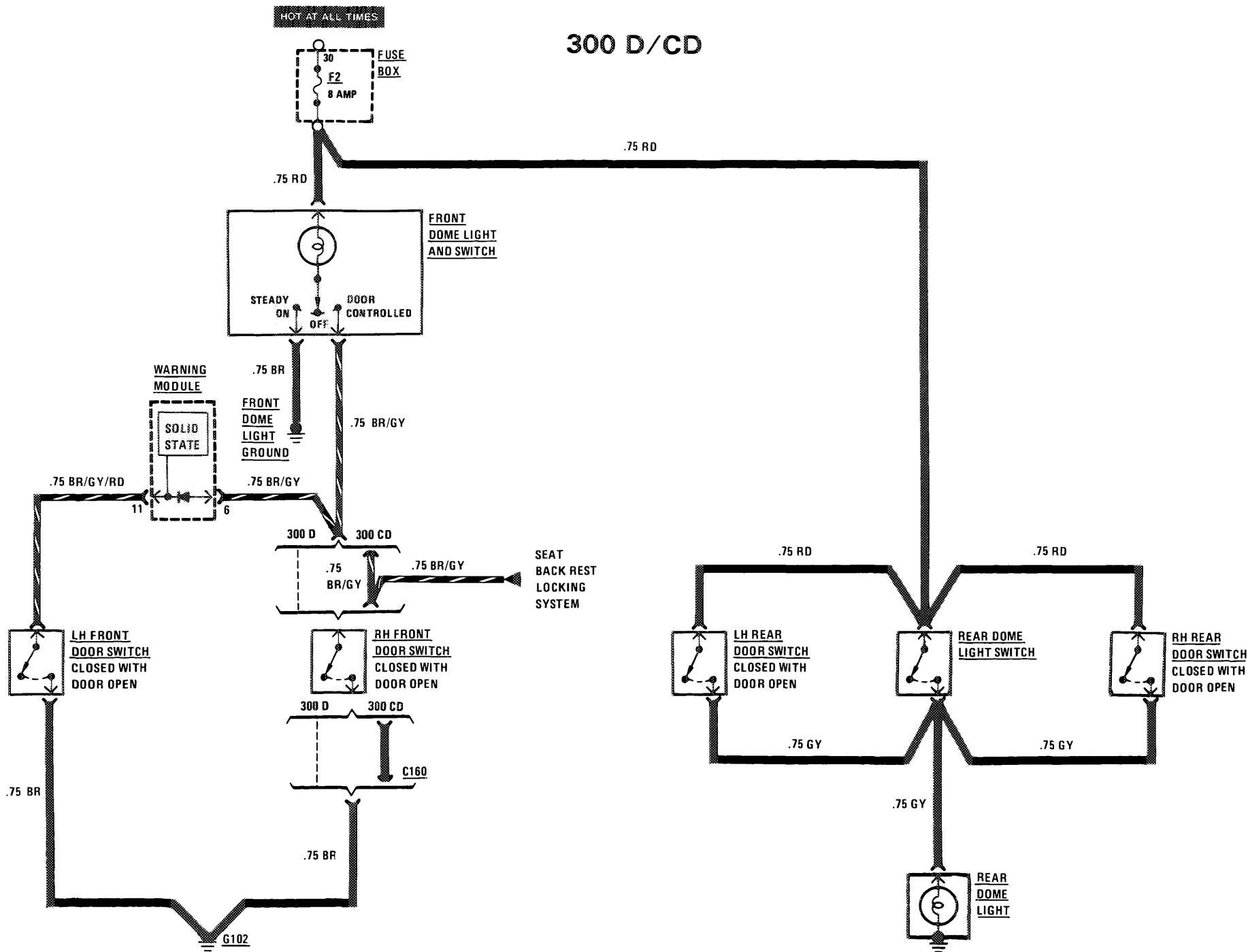

COURTESY LIGHTS

(For Component Locations See Page 203)

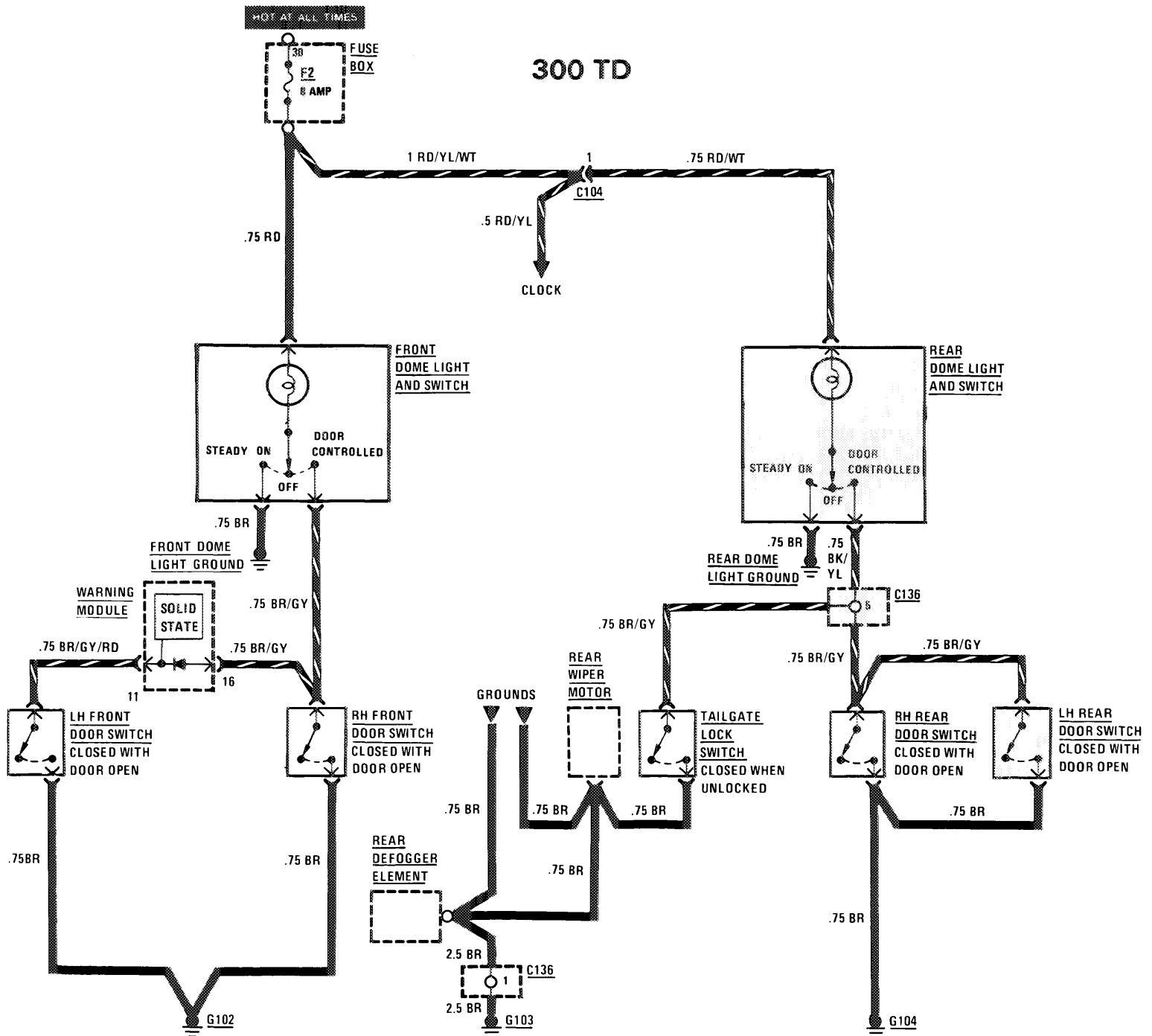

123
300
D/CD/TD
TURBO

ILLUMINATION: INSTRUMENT CLUSTER / CENTER CONSOLE

(For Component Locations See Page 201)

124
300
Q/CO/TD
TURBO

HOT AT ALL TIMES

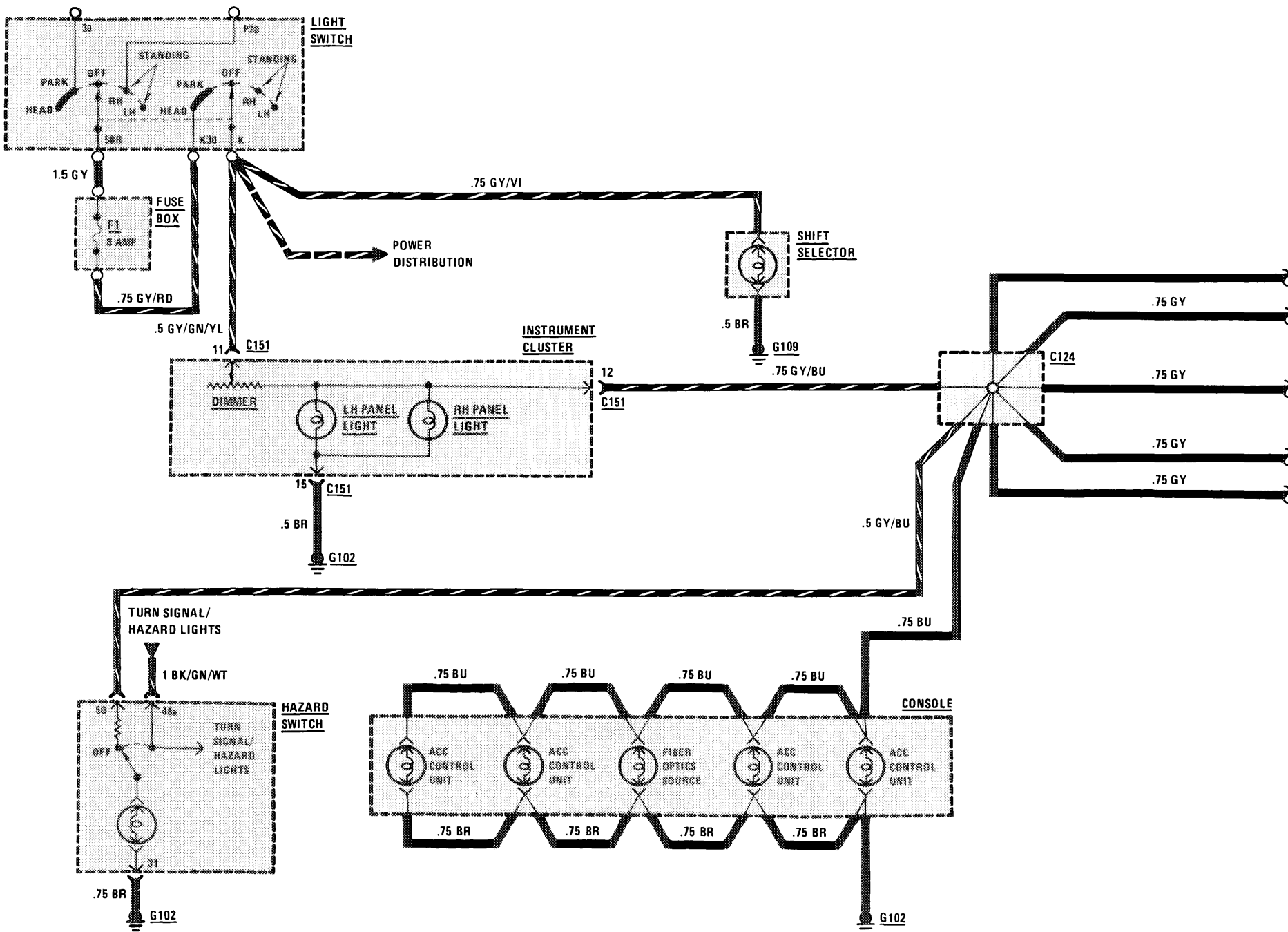

ILLUMINATION: CENTER CONSOLE

(For Component Locations See Page 201)

125
300
D/CD/TD
TURBO

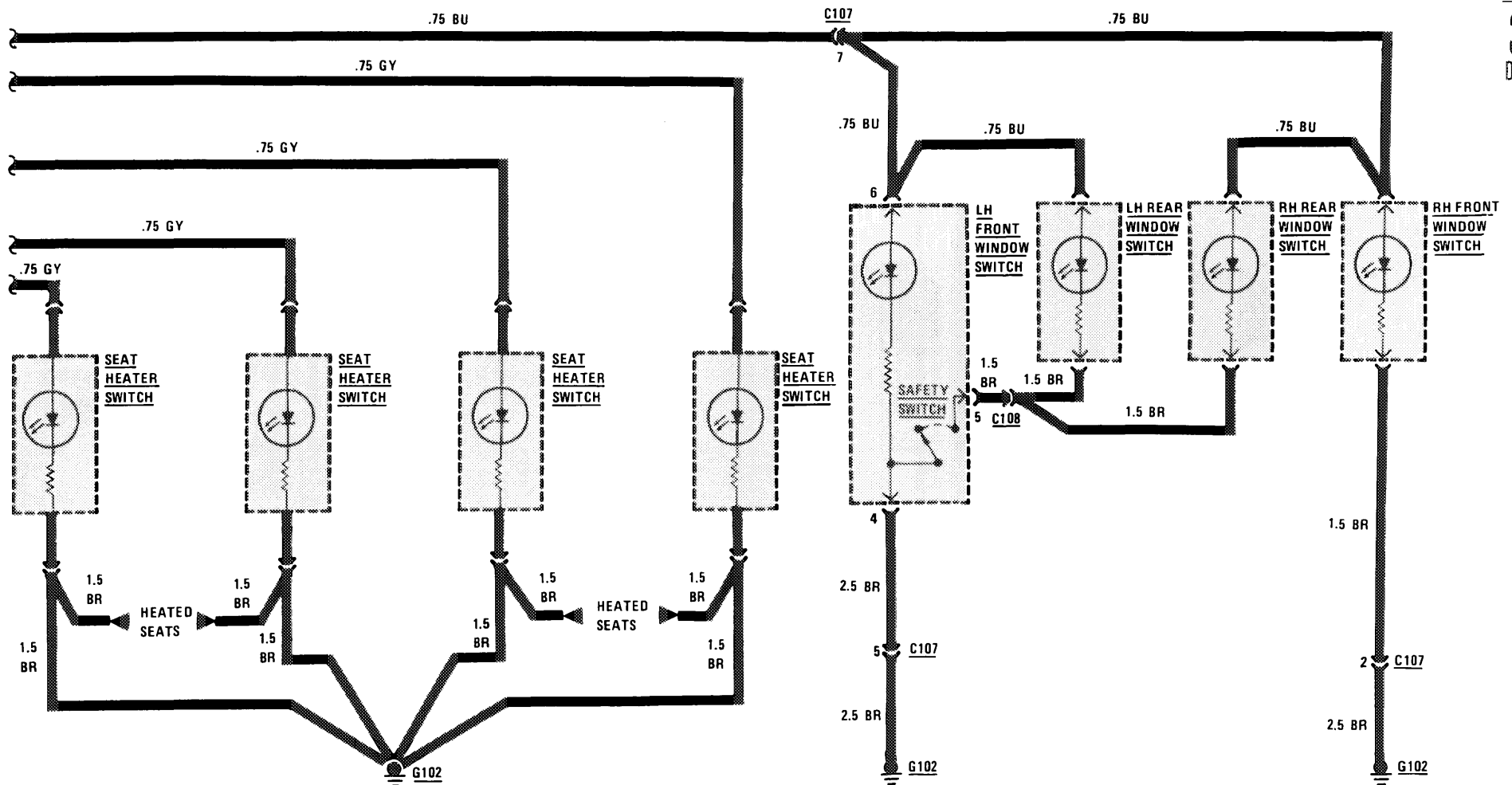

HORNS

(For Component Locations See Page 203)

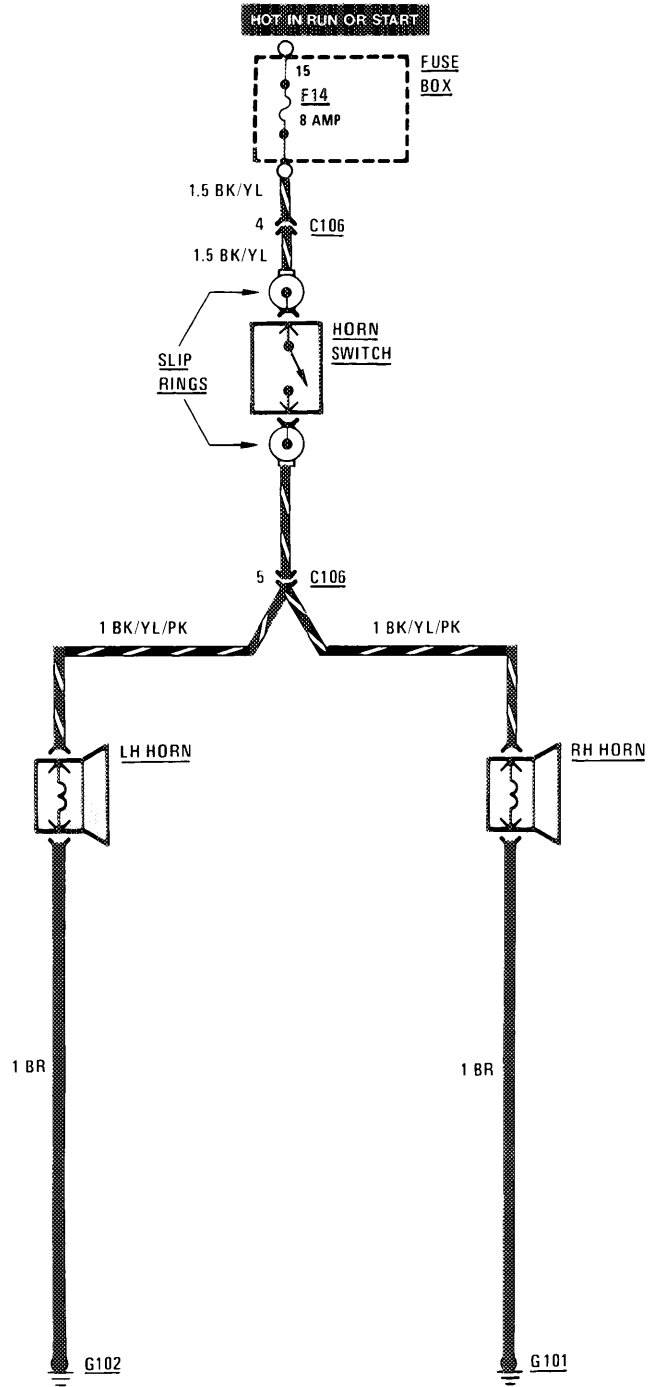

SLIDING ROOF

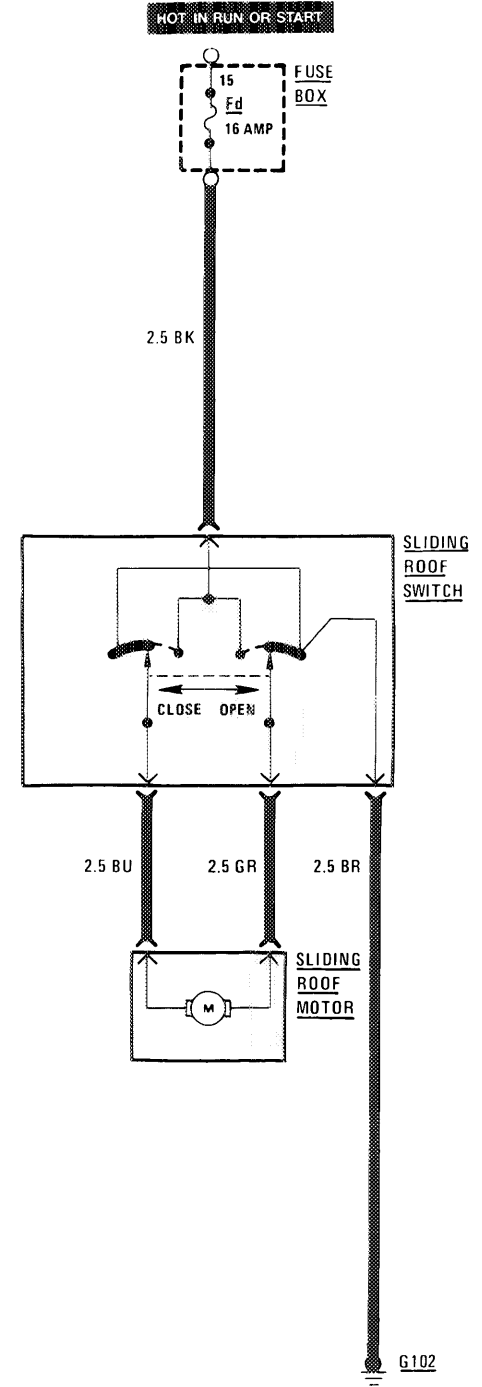

126
300
D/CD/TD
TURBO

AUXILIARY FAN

(For Component Locations See Page 201)

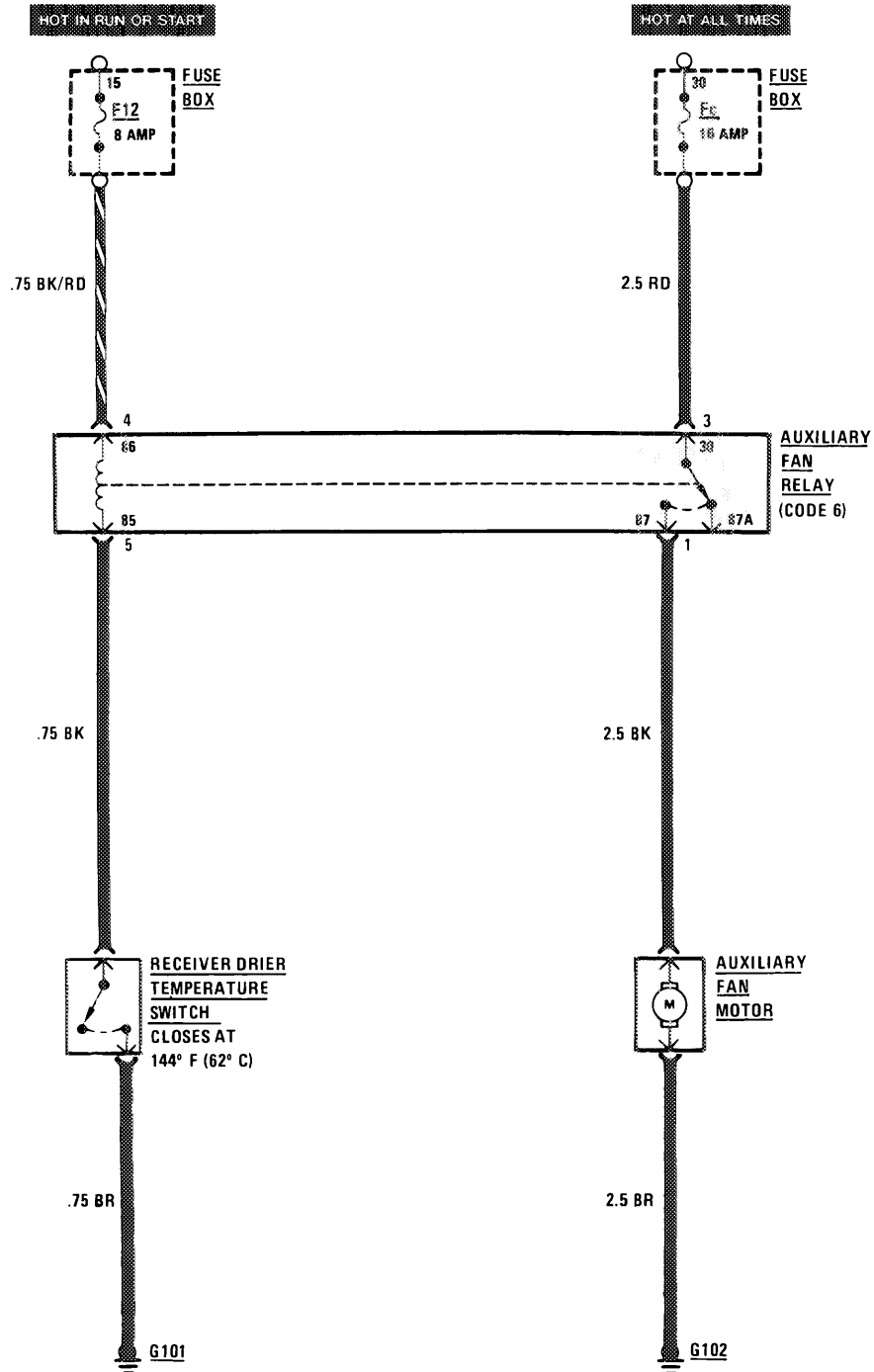

WIPER/WASHER

(For Component Locations See Page 208)

HOT IN ACCY. RUN OR START

128
300
D/CD/TO
TURBO

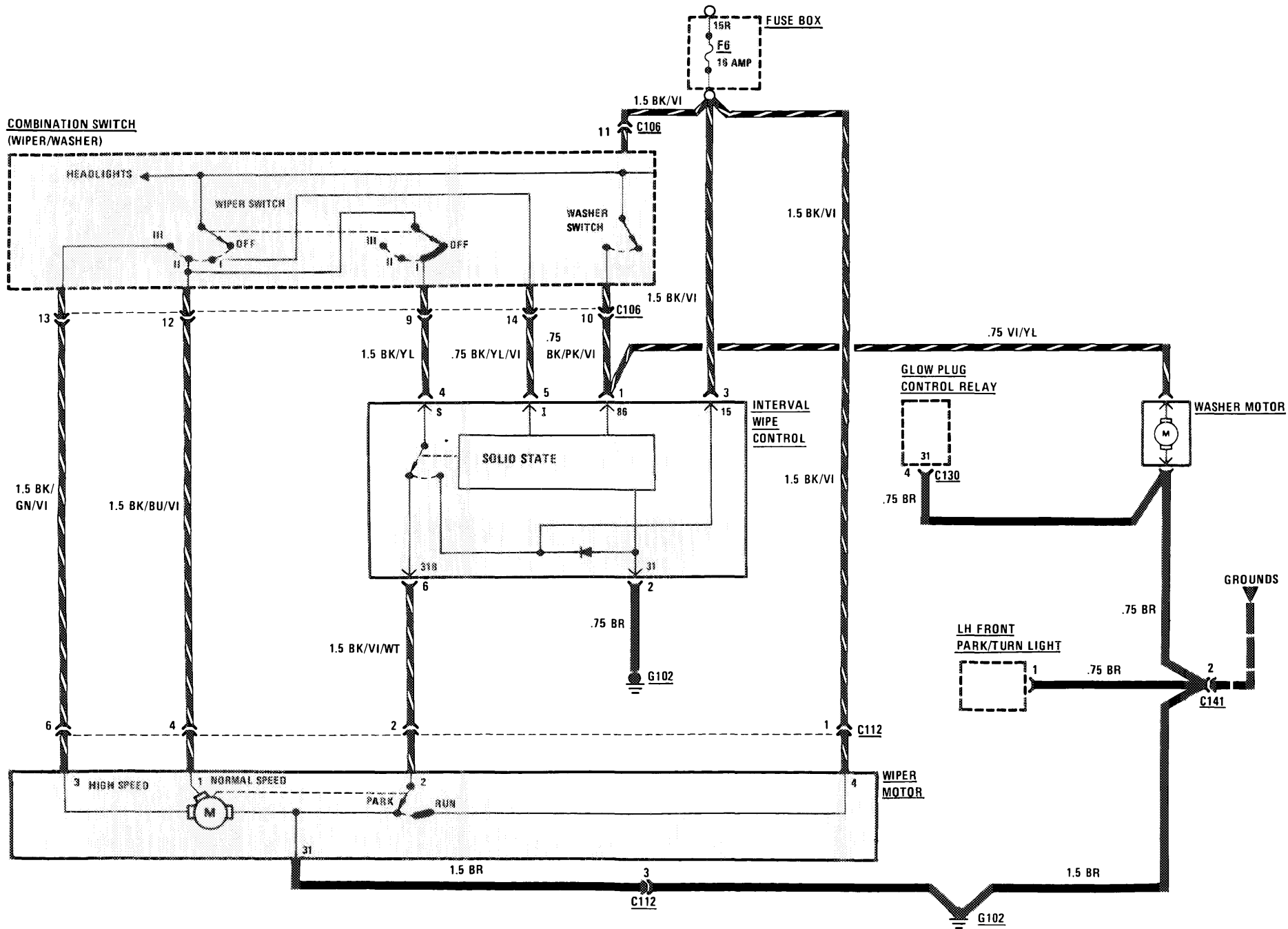

REAR WIPER/WASHER

(For Component Locations See Page 206)

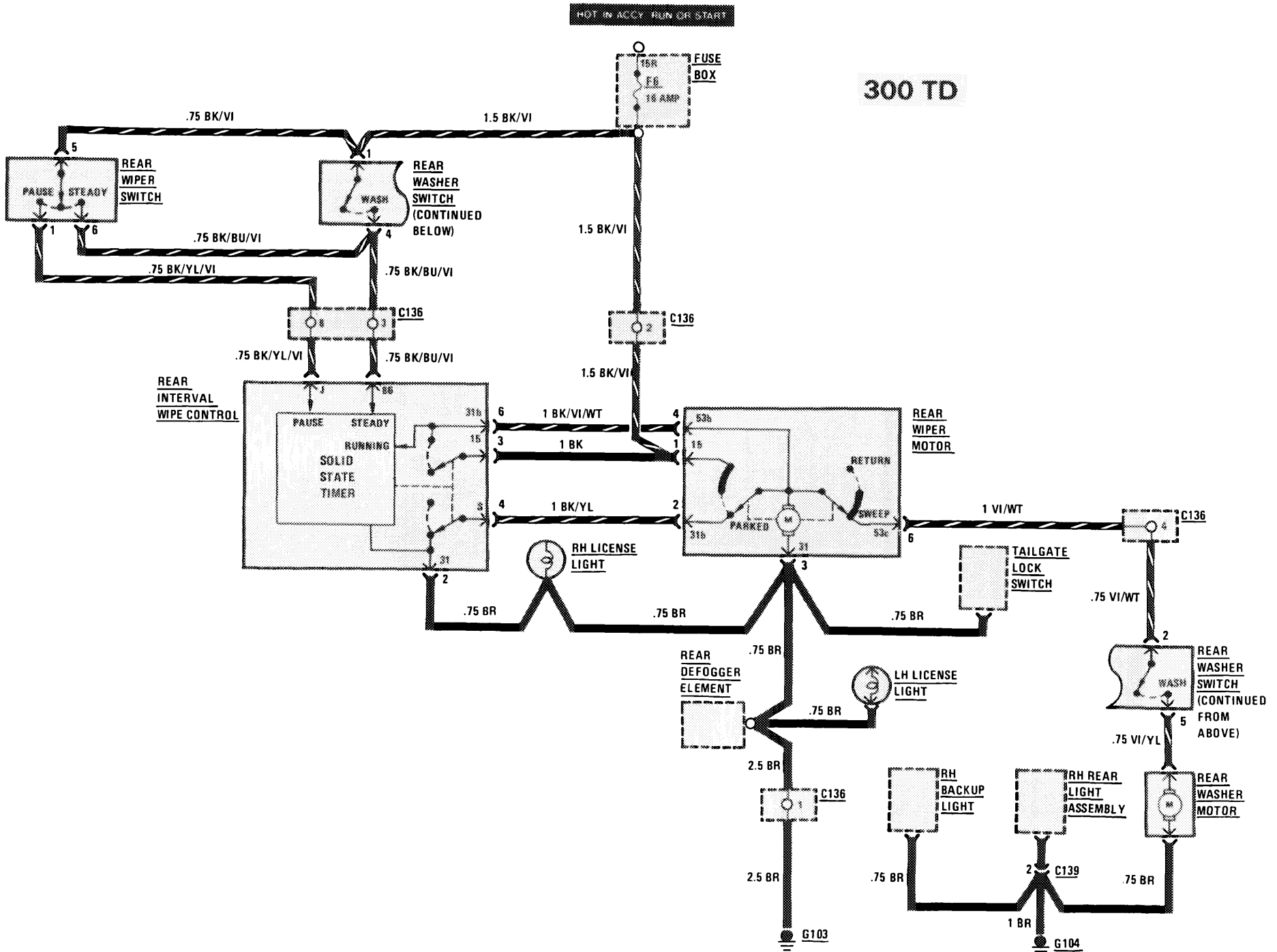

129
300
D/CD/TD
TURBO

REAR DEFOGGER

(For Component Locations See Page 205)

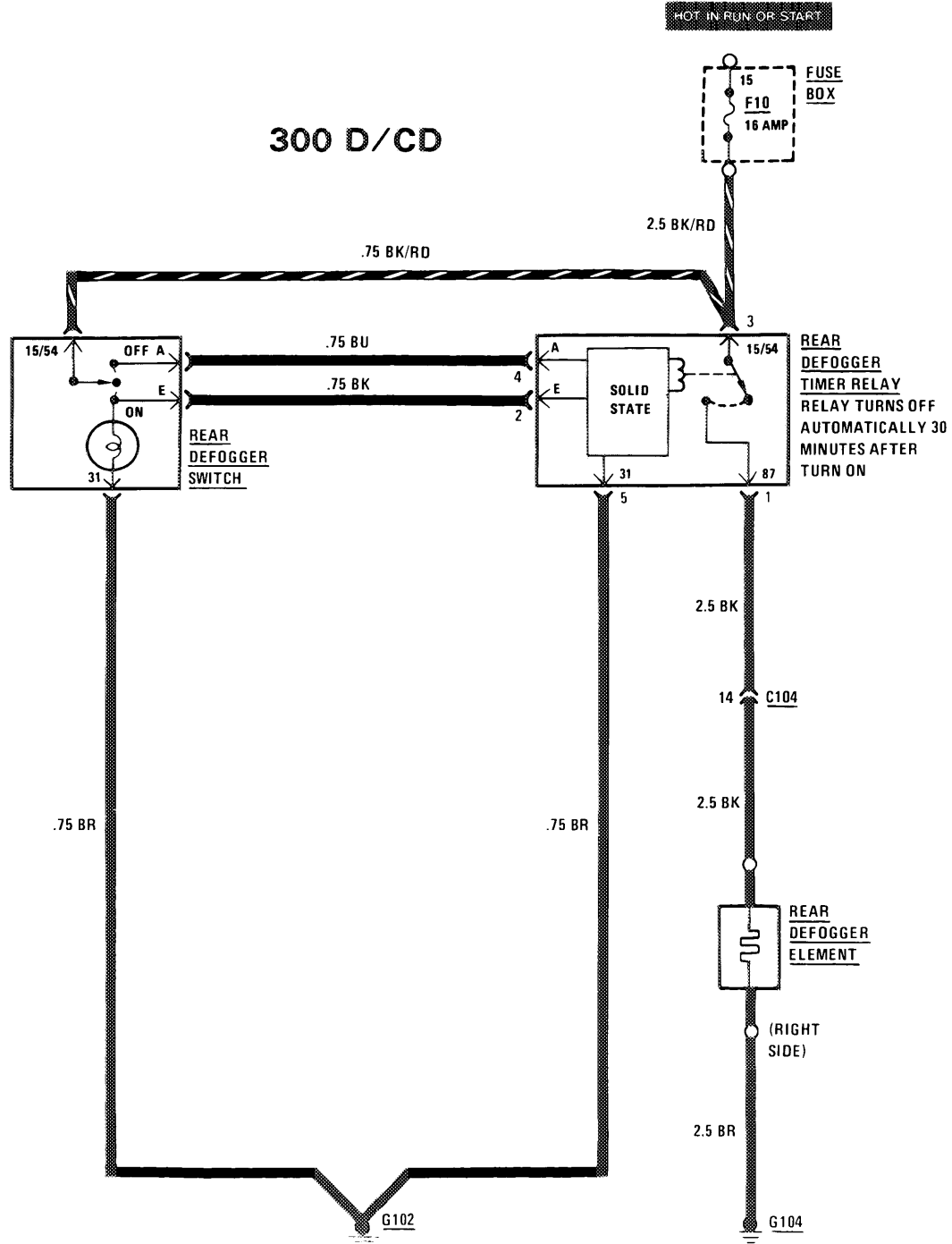

130
300
D/CD/TD
TURBO

REAR DEFOGGER

(For Component Locations See Page 205)

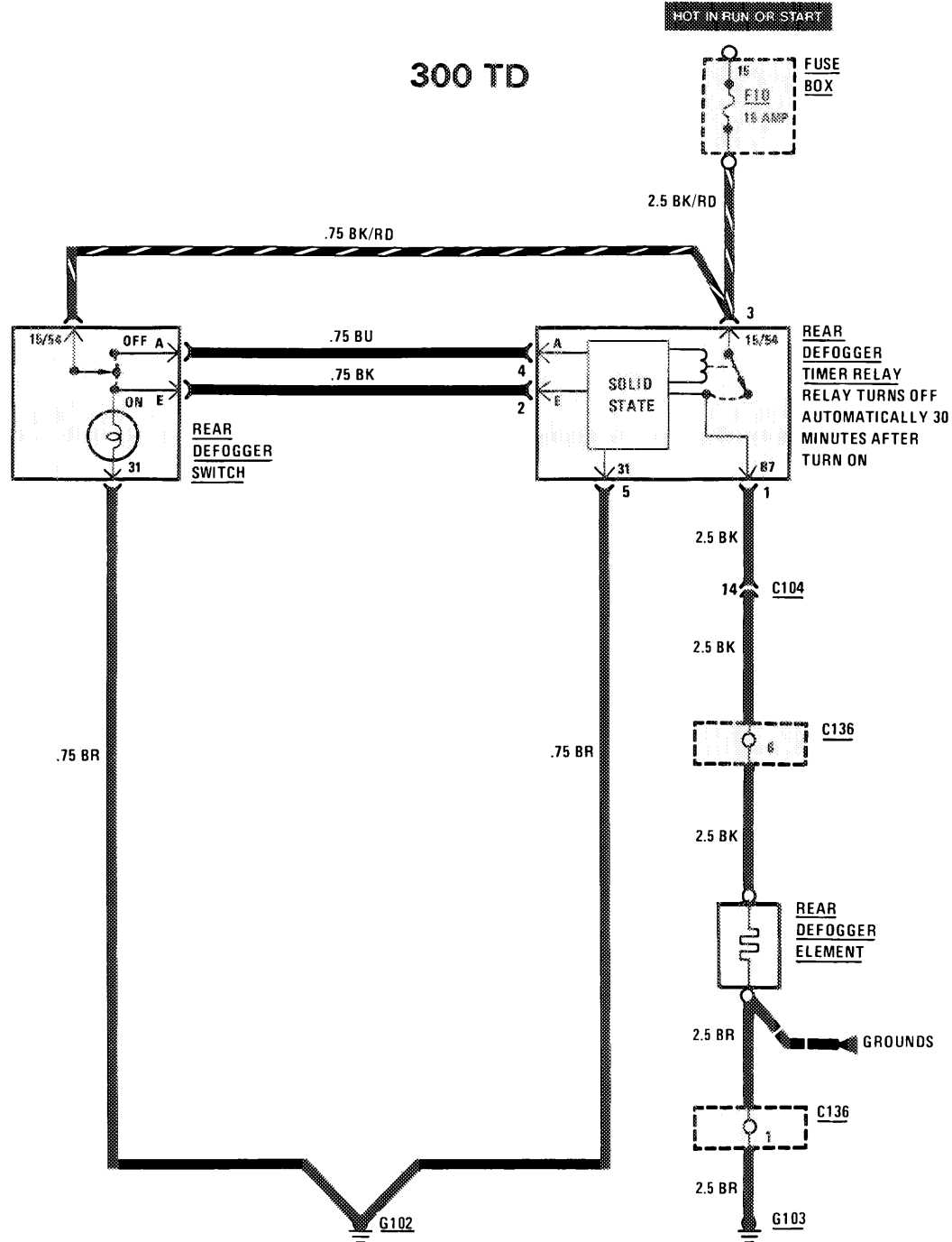

POWER WINDOWS

(For Component Locations See Page 205)

132
300
D/CD/TO
TURBO

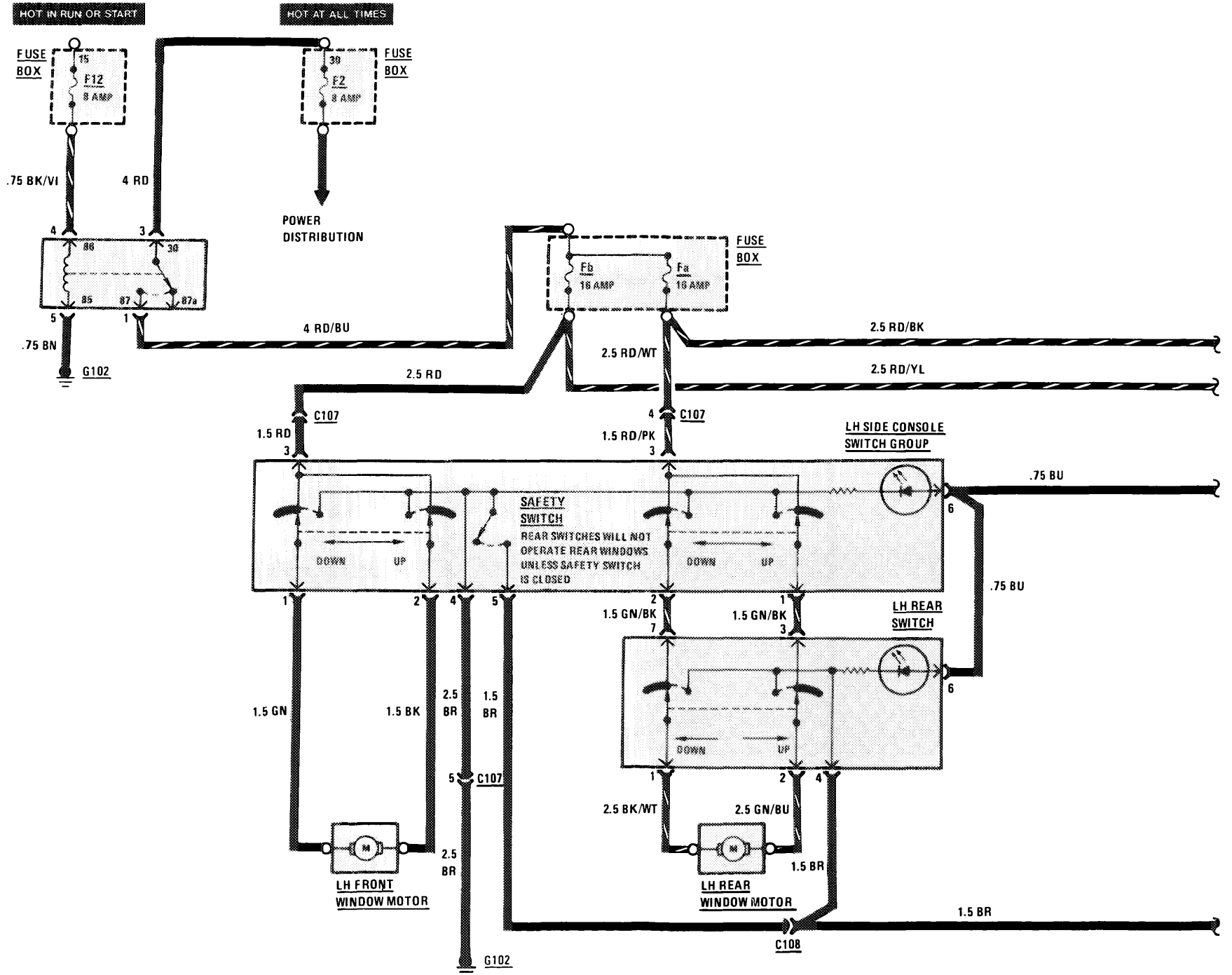

POWER WINDOWS

(For Component Locations See Page 205)

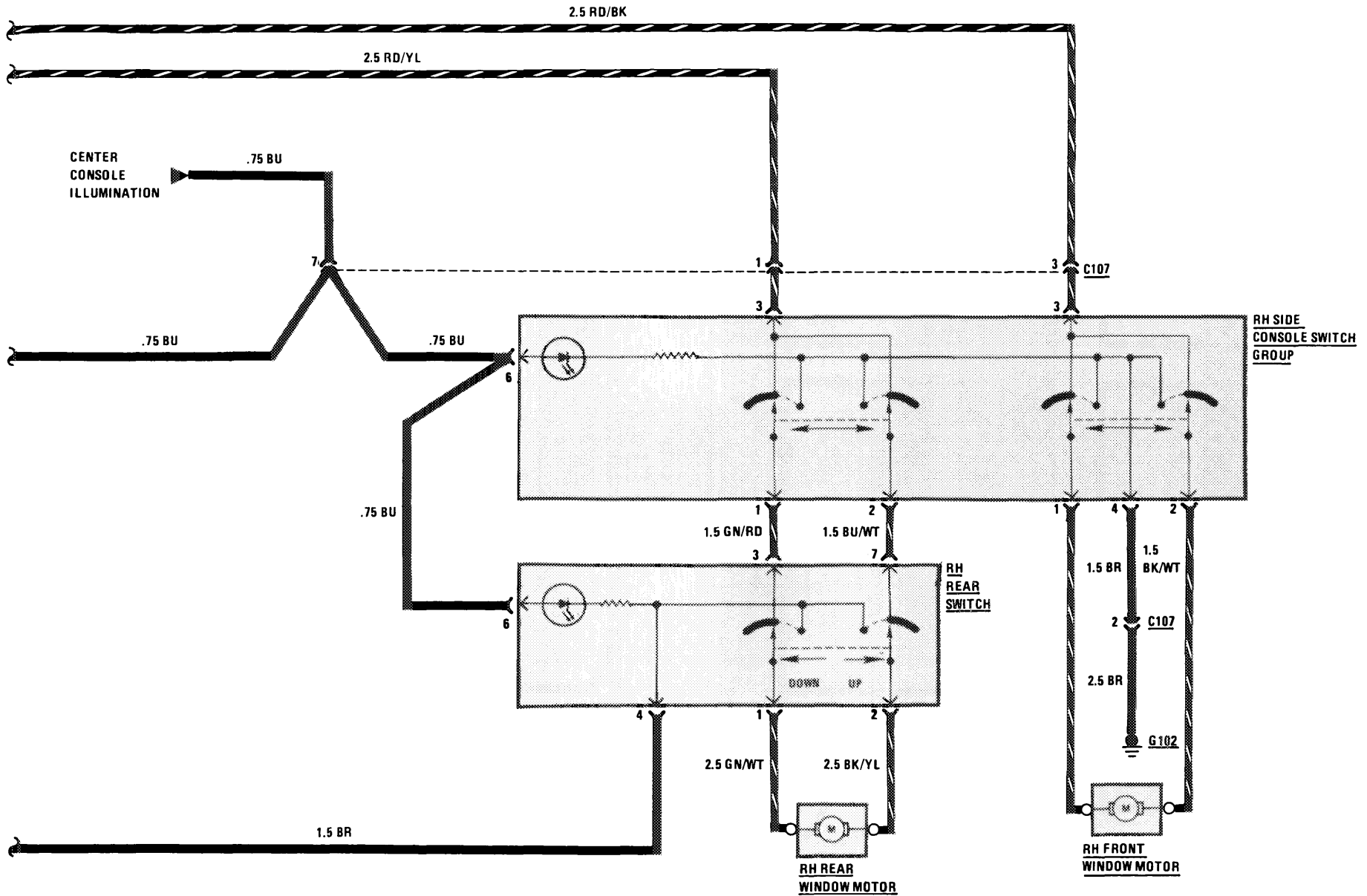

133
300
D/CD/TD
TURBO

HEATED SEATS

(For Component Locations See Page 203)

134
300
D/CD/TD
TURBO

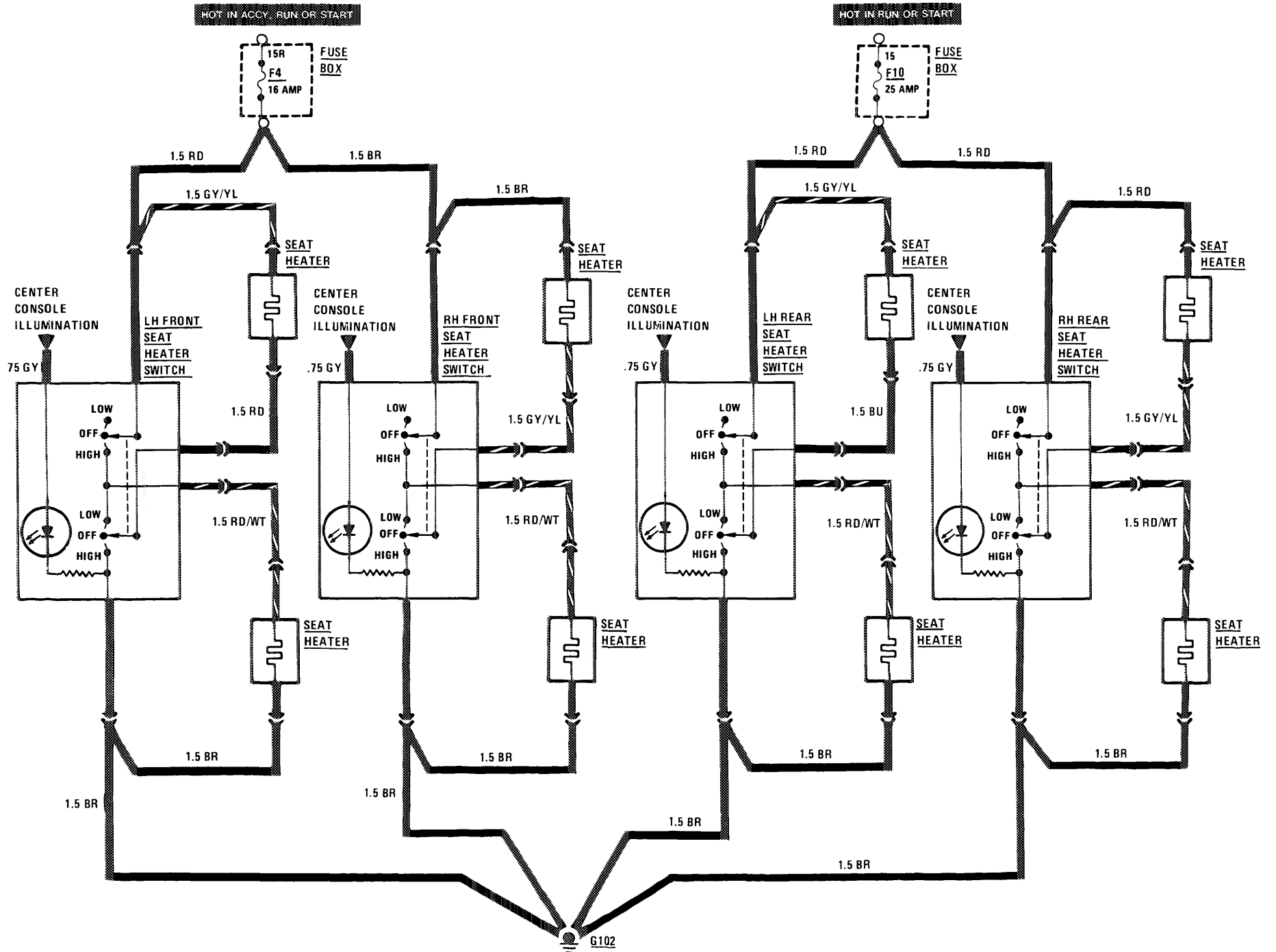

SEAT BACKREST LOCKING SYSTEM

(For Component Locations See Page 206)

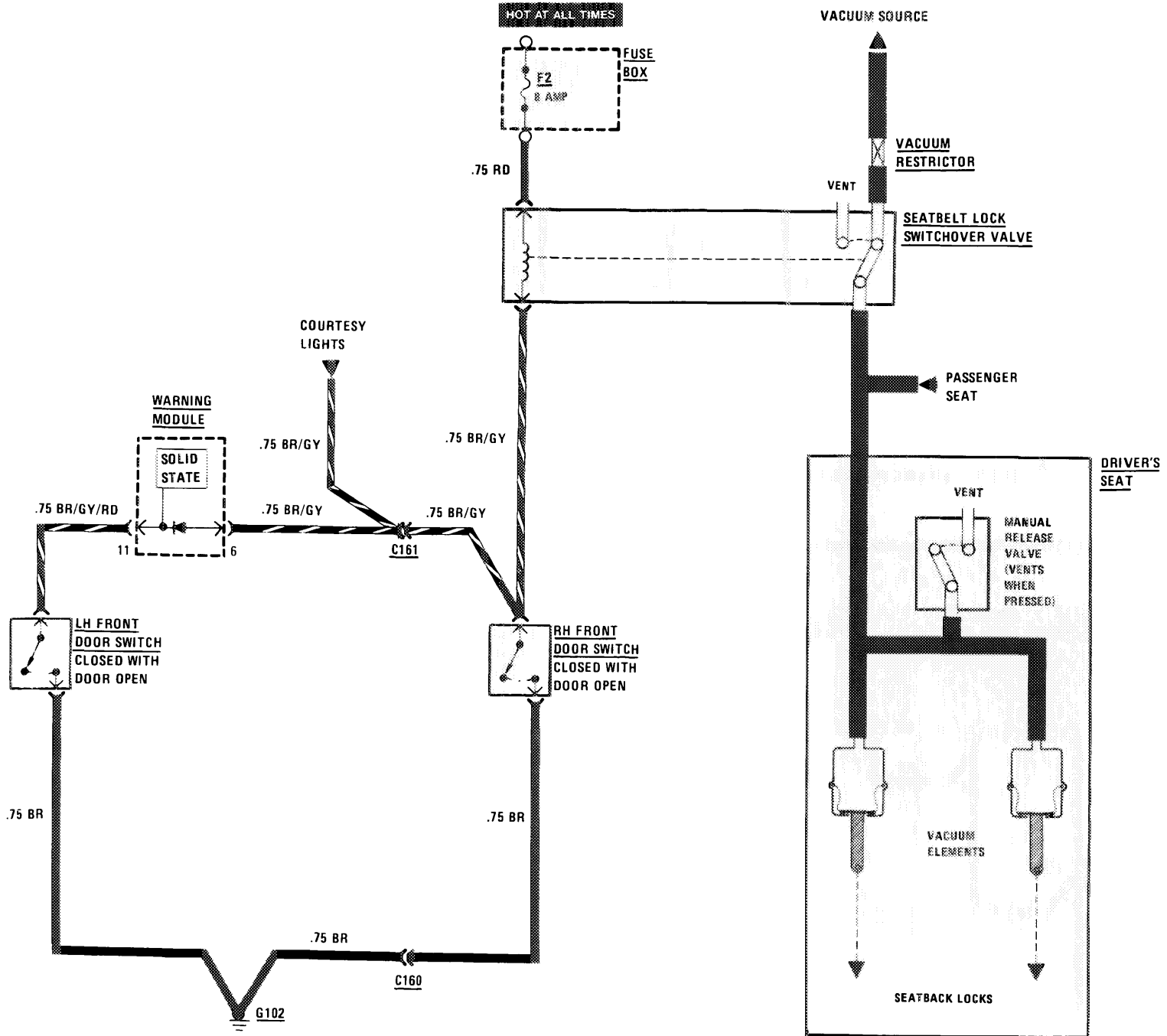

135
300
D/CD/TD
TURBO

GROUND DISTRIBUTION

136
300
Q/CD/TD
TURBO

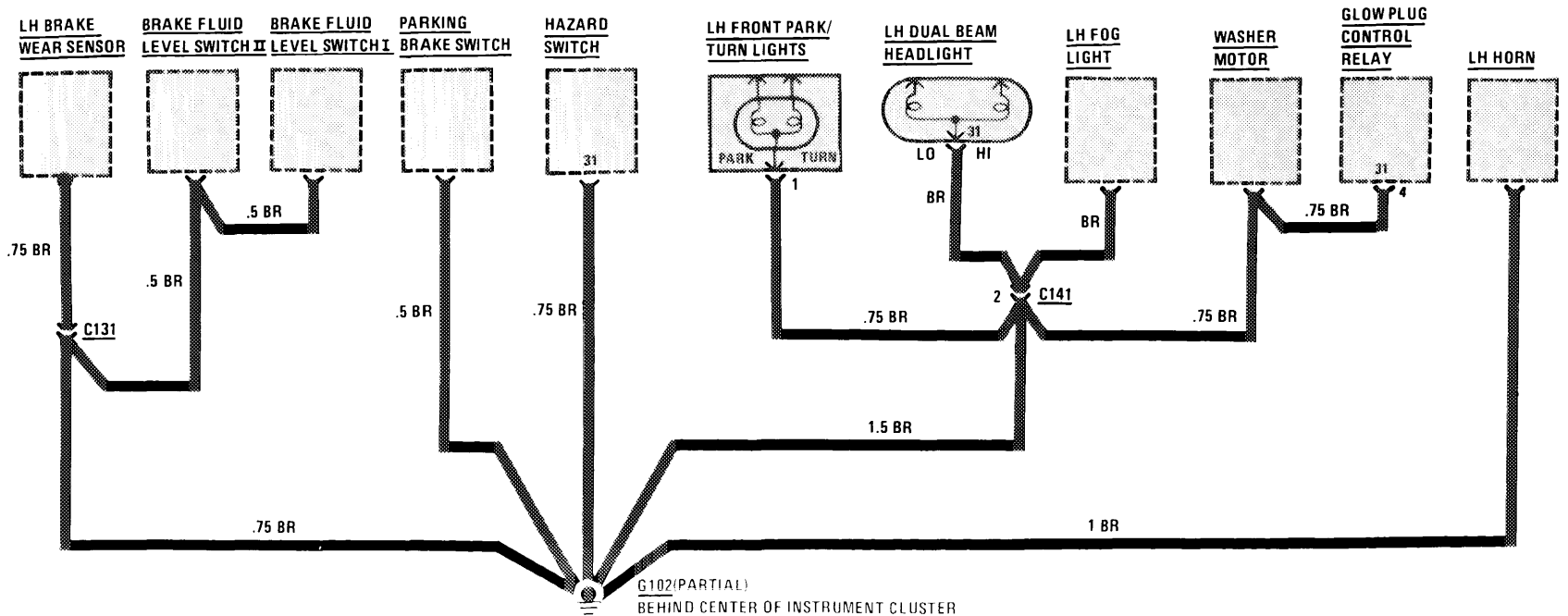
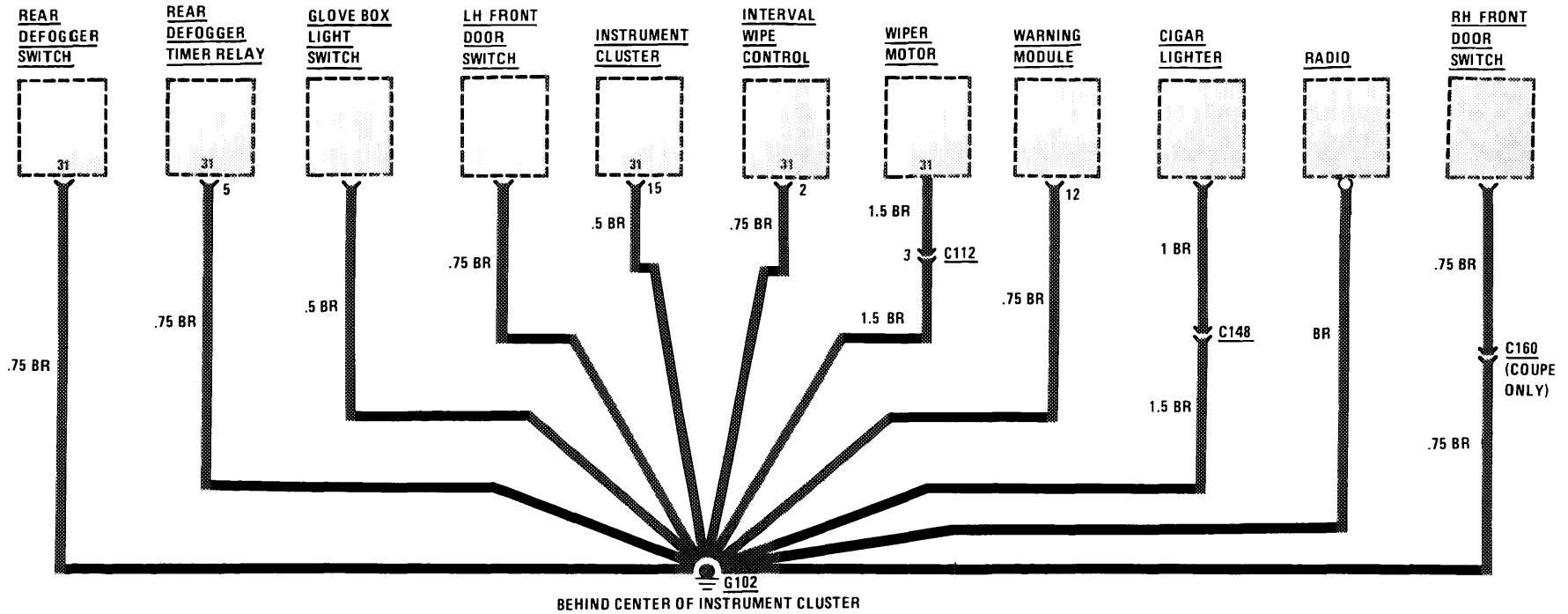

GROUND DISTRIBUTION

300 TD

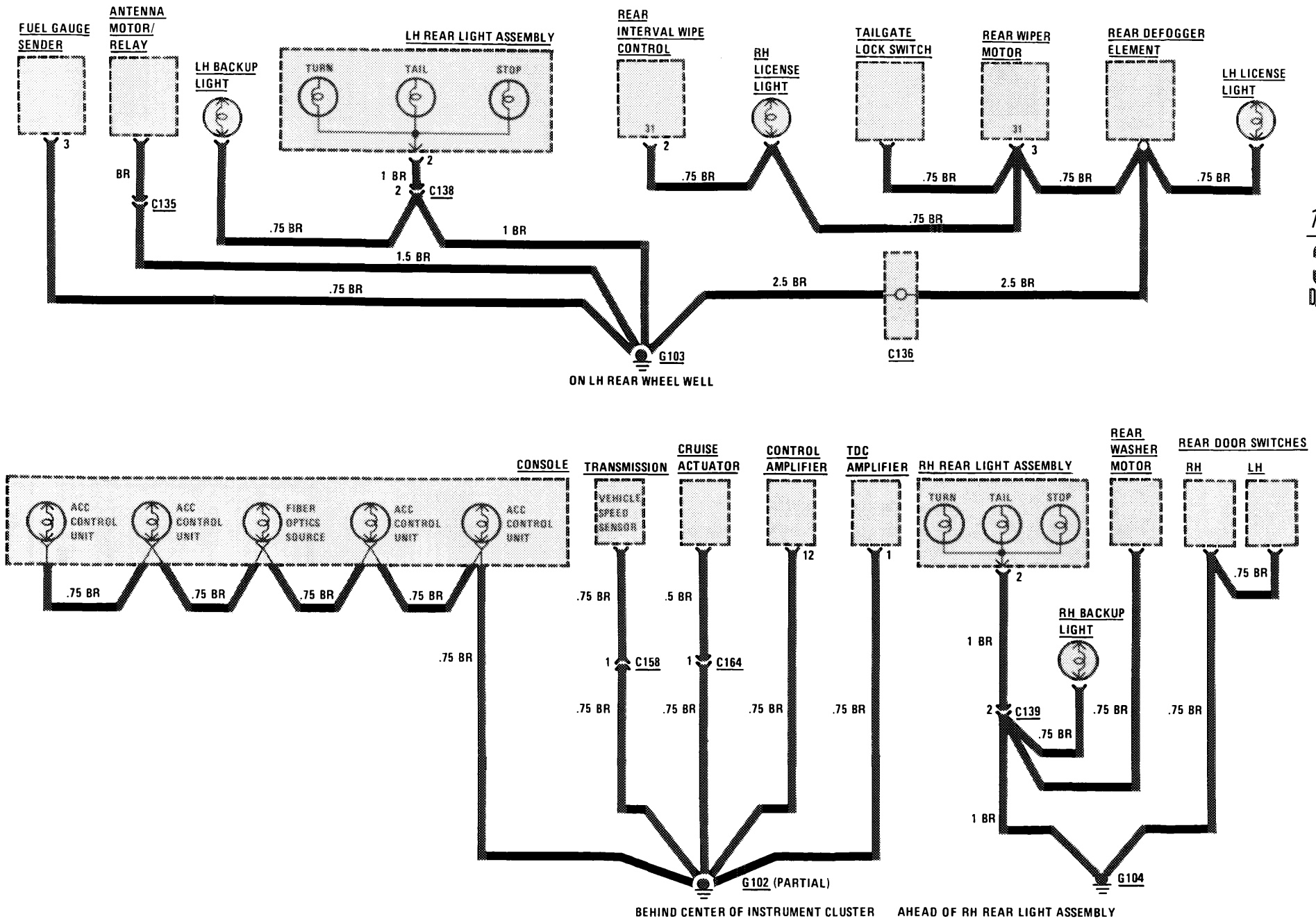

137
300
D/CO/TD
TURBO

GROUND DISTRIBUTION

300 D/CD/TD

138
300
D/CD/TD
TURBO

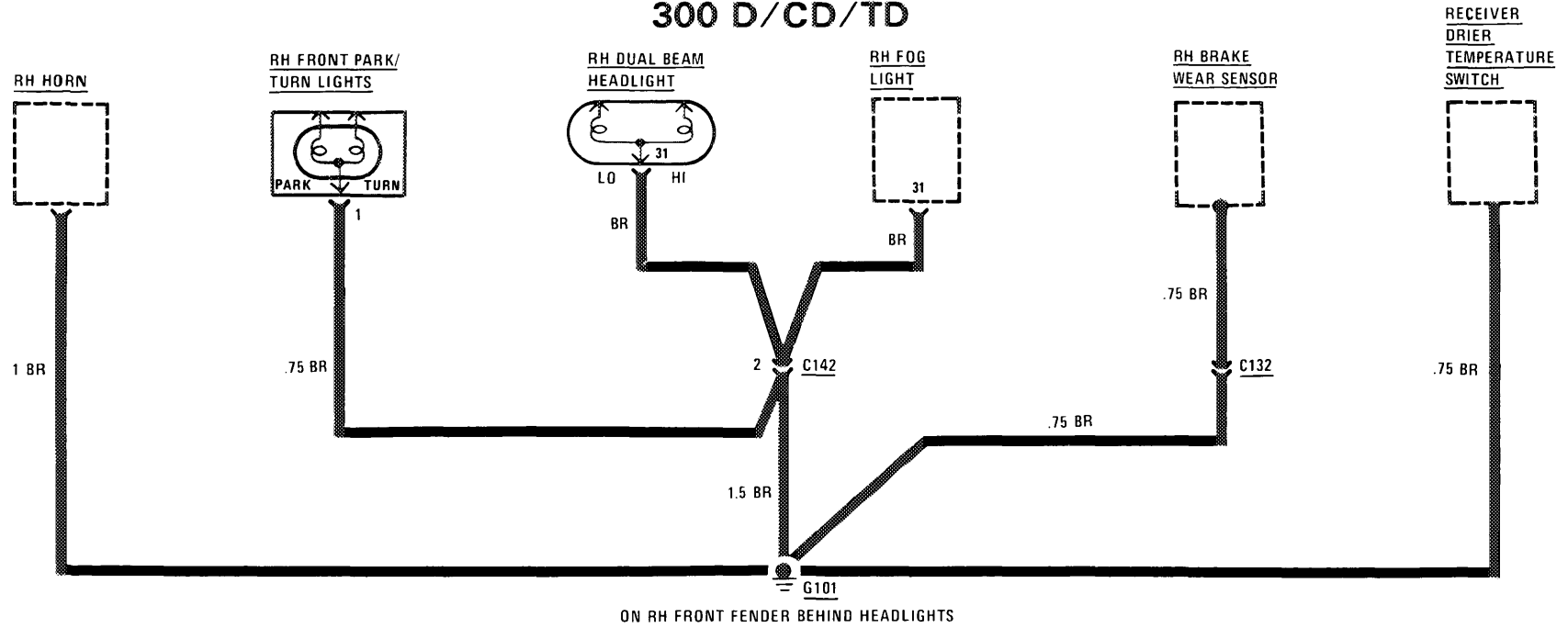

G101
ON RH FRONT FENDER BEHIND HEADLIGHTS

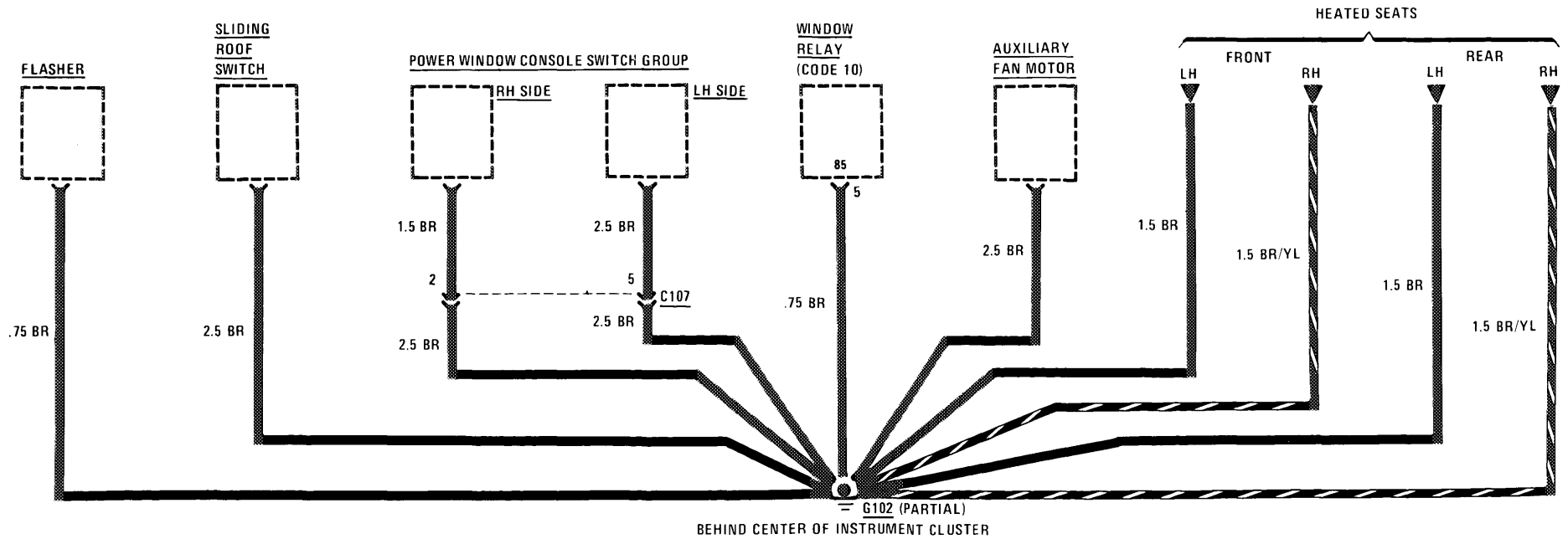

G102 (PARTIAL)
BEHIND CENTER OF INSTRUMENT CLUSTER

GROUND DISTRIBUTION

(300 D/CD)

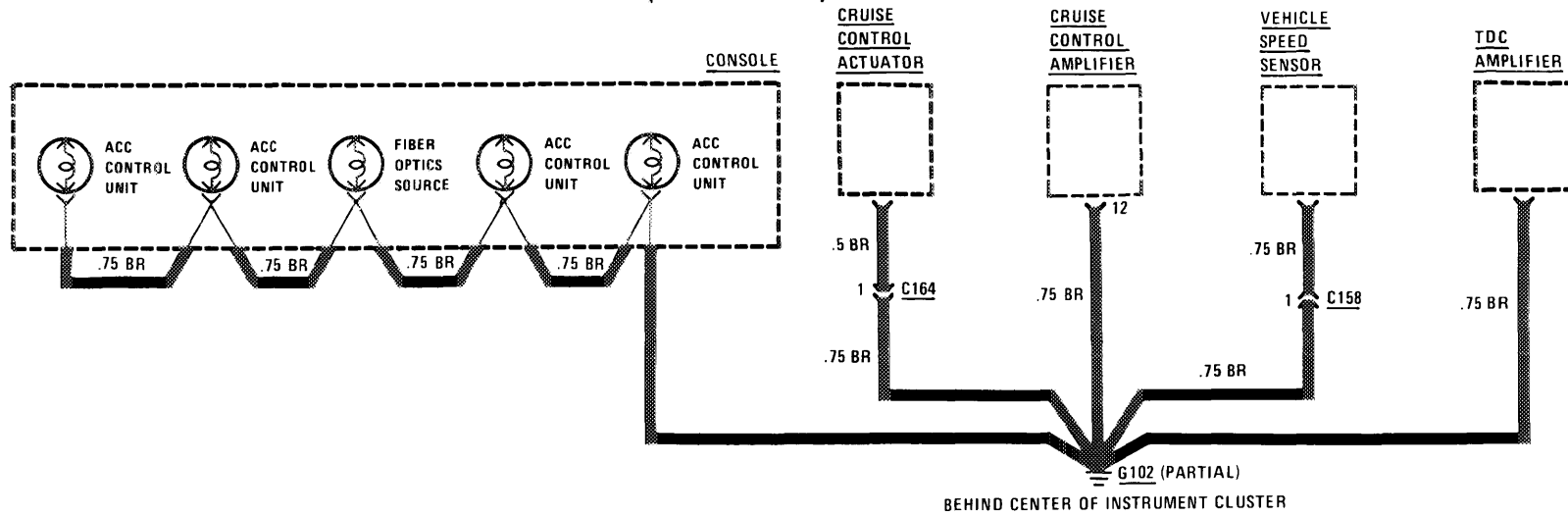

139
300
D/CD/TD
TURBO

