



00—241 Retrofitting engine shock absorber (engines 615, 616 in type 123.1)

Tightening torques		Nm	(kpm)
Bolts for engine bearer on engine mount front	M 12	70	(7)
	M 10	40	(4)
Adjusting screw for front engine mount		130	(13)
Adjusting screw for rear engine mount		40	(4)
Nut (transmission to engine mount — reference value)		70	(7)
Center bolt and nut for oil filter cover		20–25	(2–2.5)

Special tools

Torque wrench handle 20–100 Nm (2–10 kpm)		001 589 35 21 00
Torque wrench handle 50–200 Nm (5–20 kpm)		001 589 44 21 00
Attachable ratchet, 1/2" drive for torque wrench handle		001 589 42 09 00

Shop-made tool

Gauge to adjust front engine mount
(type 123.1)

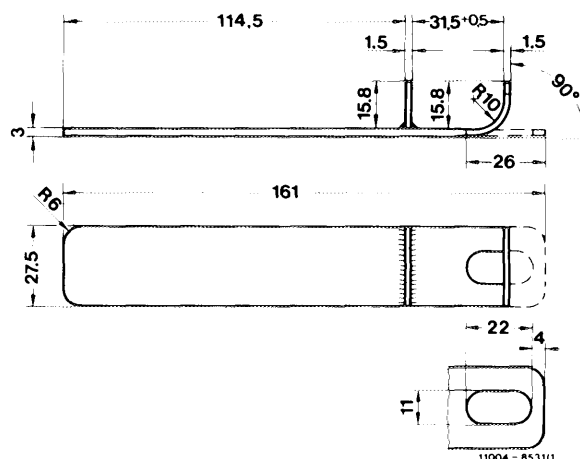

Note

Models with automatic transmissions have one engine shock absorber starting at the end chassis Nos. indicated below.

Type	End chassis No.
123.120	112 085
123.126	043 737
123 102/103/123/125	077 327
123.183	Series introduction

The engine shock absorber is located between the left-hand engine bearer (straight-ahead) and crossmember (arrow).

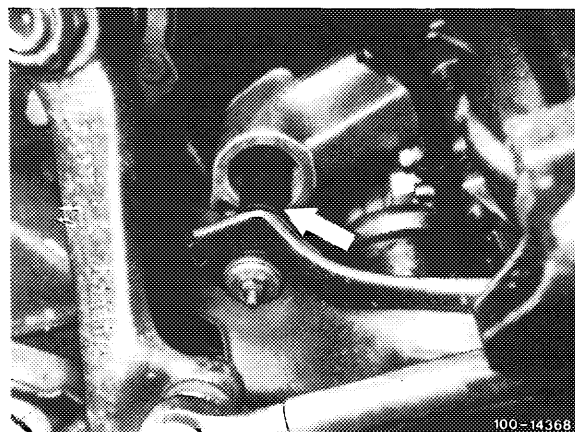

If a model which has a lower end chassis No. is brought in on account of vibrations (stuttering), it can be retrofitted with the engine shock absorber.

The engine shock absorber must not be used in models with manual transmissions.

Scope of parts

Qty.	Part	Part No.
1	Engine bearer	115 223 16 04
1	Engine shock absorber	123 240 05 48
1	Flange	123 241 00 45
2	Disk washer	115 241 07 12
1	Disk washer	123 241 02 12
2	Buffer	123 241 00 65
2	Buffer	123 241 03 65
2	Nut M 6	913002 006002
2	Screw assembly M 6 x 15	914004 006001
1	Screw assembly	123 990 02 12
1	Shield	123 241 07 34

Installation

- 1 Turn steering to full left or right lock.
- 2 Remove engine bearer bolts at engine mount, working from below.

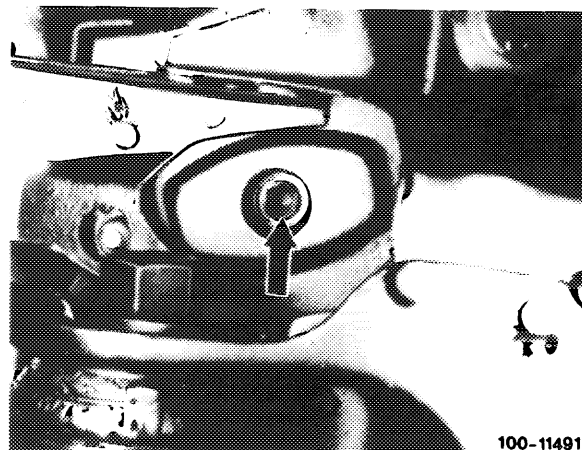

3 Lift up retainer (30) at front engine mount, swing away to one side and remove adjusting screw (31).

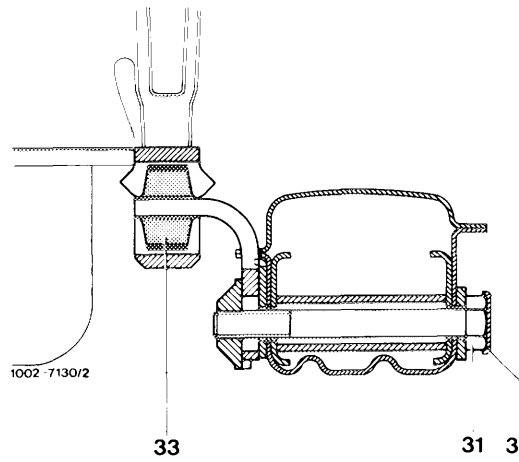

- 30 Retainer
- 31 Adjusting screw
- 33 Engine stop

4 Unscrew support on transmission bracket at exhaust side (arrow).

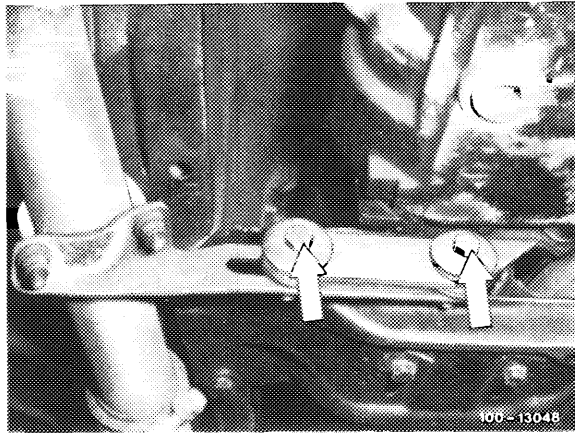

5 Release adjusting screw at rear engine mount (arrow).

6 On engine models 615, 616 featuring injection pumps with pneumatic governors, release and remove rubber gaiter at throttle body.

7 For models with power steering, remove oil from power steering pump reservoir and unscrew or release oil hoses at power steering.

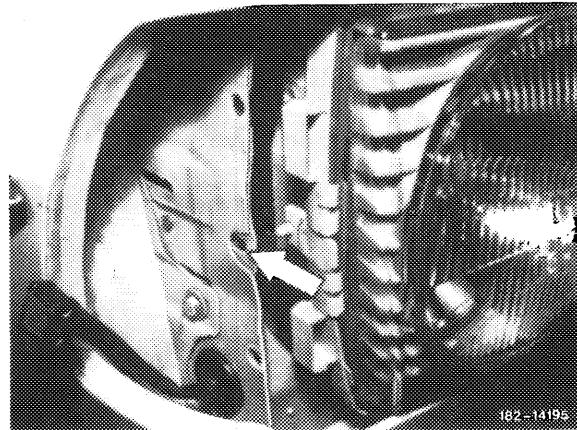

8 For engine models 615, 616 with air-conditioners and engine model 617 in general, unscrew and remove oil filter cover.

Unscrew oil cooler lines at oil filter housing (arrows) and unscrew clamp (1).

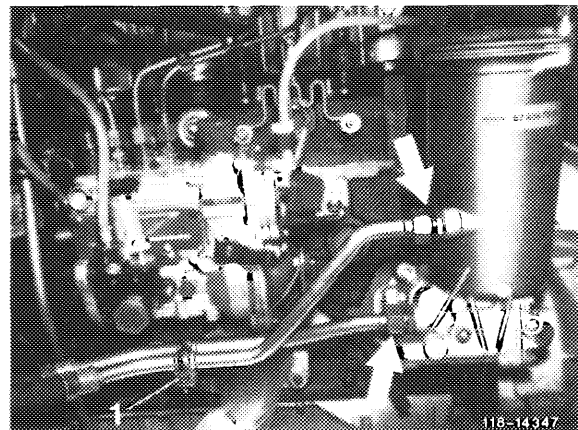

9 Raise engine, applying inspection pit lift to oil pan.

Note: Insert wood support to avoid damage to oil pan.

10 Withdraw left-hand shield at engine mount (straight-ahead).

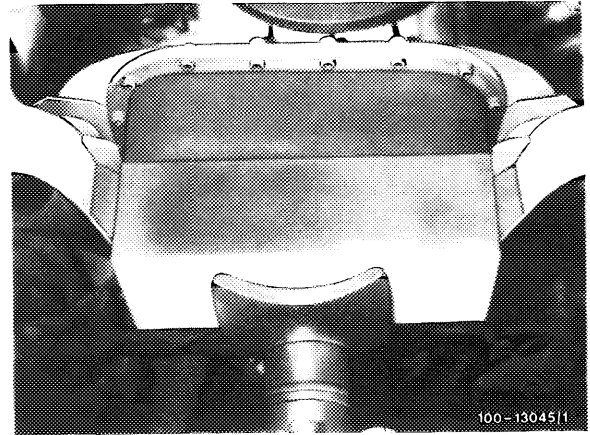

11 Unscrew and remove left-hand engine bearer (straight-ahead).

Note: To remove engine bearer, tilt slightly upward.

12 Insert and fasten new engine bearer. The nut tightening torque is 55 Nm (5.5 kpm). Fit engine bearer from above and slide onto studs.

Note: This engine bearer has an M 10 thread (formerly M 12) for fastening to engine mount. Therefore use screw assembly M 10 x 40 (formerly M 12 x 35).

13 Position new shield on engine mount.

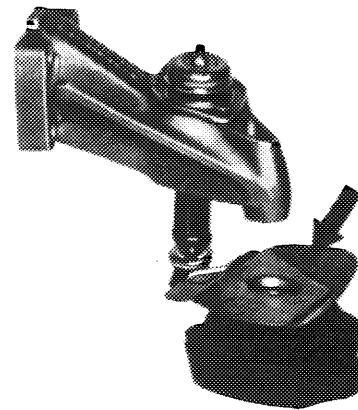

Shield, left

14 Lower engine, noting position of shields.

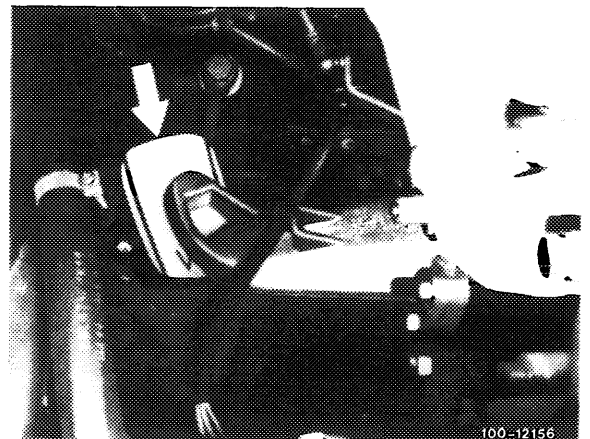

Shield, right

15 Place engine bearer bolts on engine mount and torque to 70 Nm (7 kpm) or 40 Nm (4 kpm).

Caution:

The thread in the engine bearer has been modified from M 12 to M 10. The engine bearer also has an M 10 thread.

In older models, therefore, substitute screw assembly M 10 x 40 for screw assembly M 12 X 35.

16 Insert engine shock absorber so that piston rod passes through hole in engine bearer from top to bottom.

17 Slightly lift engine shock absorber from below and position upper disk washer (46) and upper rubber buffer (47) on piston rod.

- | | |
|-------------------|--------------------------|
| 40 Nut M 6 | 45 Engine shock absorber |
| 41 Disk washer | 46 Disk washer |
| 42 Rubber buffer | 47 Rubber buffer |
| 43 Flange | 48 Crossmember |
| 43a Engine bearer | |

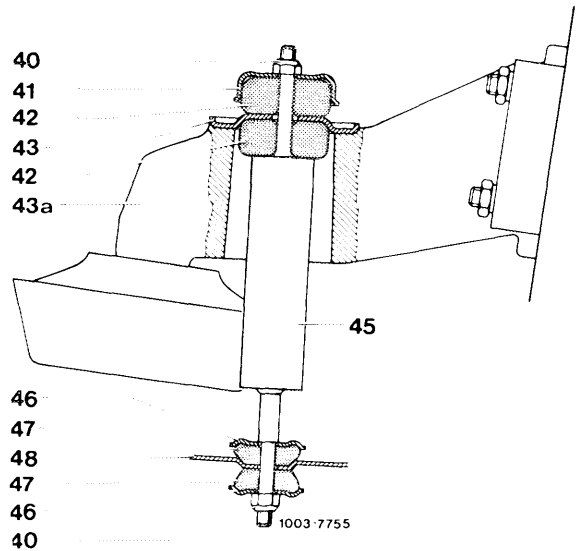

18 Pass piston rod through hole in crossmember (arrow).

19 Place lower rubber buffer (47) and lower disk washer (46) in position.

20 Apply lower nut (40).

21 Position lower rubber buffer (42) on engine shock absorber.

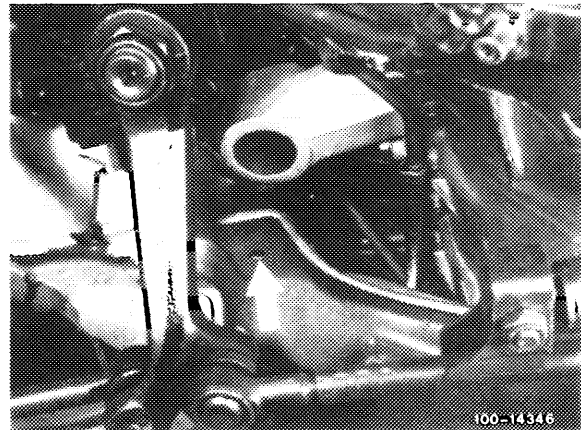

22 Place flange (43) on engine bearer (43a) and fasten with two screw assemblies M 6 x 15.

23 Place upper rubber buffer (42) and upper disk washer (41) in position.

24 Position and tighten upper nut (40). To do so, secure engine shock absorber.

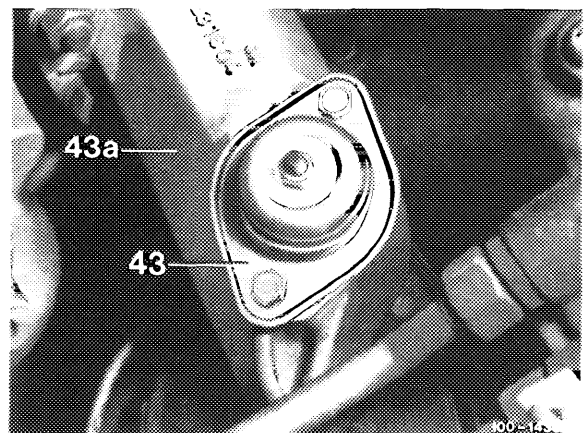

25 Tighten lower nut (40). To do so, secure piston rod at place provided for this purpose (arrow), using a wrench.

Caution:

The engine shock absorber must be mounted in holes without touching sides of holes.

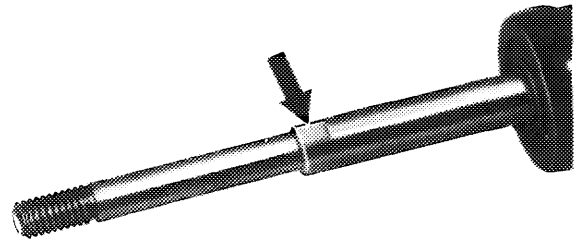

100 - 13099

26 Move engine by gently rocking from side to side with your hands.

27 Position shop-made gauge (01) on front engine stop.

28 Tighten adjusting screw at rear engine mount to correct torque setting.

29 Insert adjusting screw at front engine stop and tighten to correct torque setting.

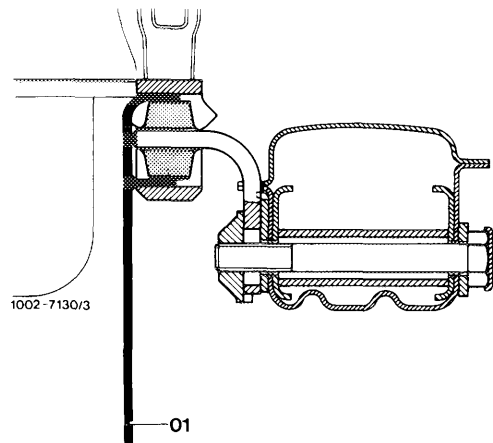

Place retainer on screw head.

30 Withdraw gauge.

31 Attach support to transmission bracket at exhaust side.

32 Slip rubber gaiter onto throttle body.

33 On engine models 615, 616 with air-conditioners and engine model 617 in general, fit oil filter cover. Screw oil cooler lines to oil filter housing. Insert and fasten clamp. Place oil filter cover in position and tighten to correct torque setting.

34 On models with power steering, connect hoses to power steering system.

Fill reservoir with oil, turning steering to left and right lock several times.