

## 03-440 Balancing flywheel statically

---

### Data

Flywheel for	Engine	Balancing holes max. depth	Drill dia.	Hole circle dia.
Manual transmission	615,616	25	11 9	270 and 242 270
Manual transmission	617	30	11	270
Automatic transmission	all	through-holes	11 9	251 252

### Special tool

Balancing drift  
(flywheel for automatic and manual transmissions)

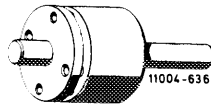

617 589 00 63 00

### Commercially available tool

Roller type EO for static balacing

Trebel, 4030 Ratingen

### Note

For engines 615 and 616 the crankshaft, balance plate and flywheel are balanced as one assembly.

In contrast, engine 617 is balanced as a whole, i.e. the entire engine is balanced on a balancing machine (03-450).

Since this balancing operation cannot be executed in a repair shop, and as engine balance has to be maintained as well as possible, it is necessary to adjust the balance of a new flywheel to that of the old one. This applies equally well to new flywheels for engines 615 and 616.

## Static balancing

- 1 Lay old and new flywheels on one another so that all holes agree and both clutch surfaces are pointing in the same direction.
- 2 Insert balancing drift and bolt new flywheel to old one, set off exactly by  $180^\circ$ .

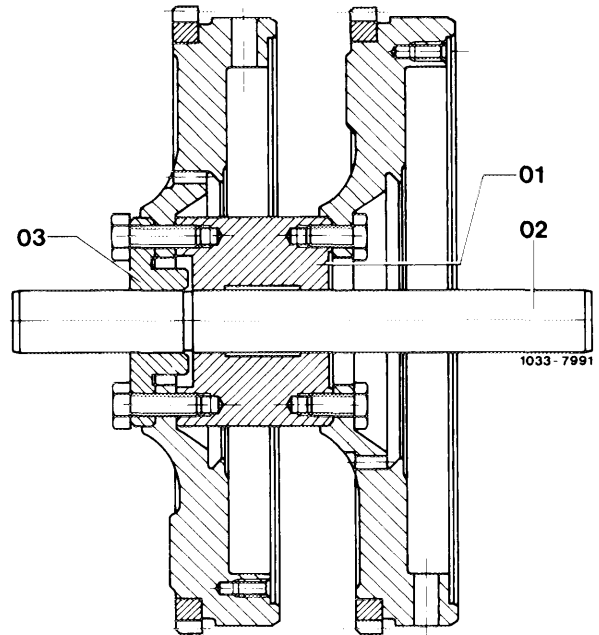

- 01 Mounting
- 02 Shaft
- 03 Centering plate

- 3 Allow balancing drift with two flywheels to settle down on roller.

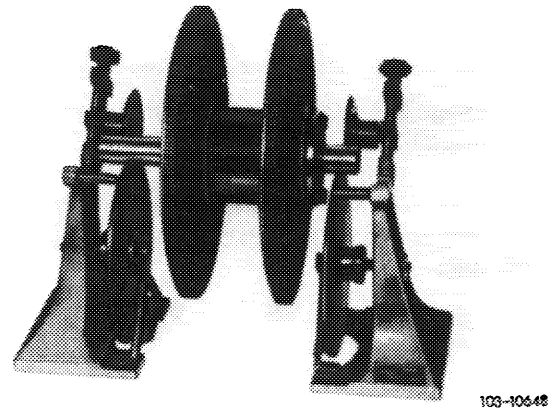

- 4 Any unbalance can be corrected by drilling holes in the "heavy" side of new flywheel until both flywheels stop at any position without swinging backward or forward.

### Caution:

Be sure to observe hole circle diameter, drill diameter and maximum drilling depth.

The dust holes (arrows) must not be drilled open.

