





## 05—110 Retightening hexagon socket cylinder head bolts

Tightening torques at operating temperature	Nm	(kpm)
Cylinder head bolts	100	(10)
Bolts for cylinder head cover (engine 615)	5	(0.5)
Nuts for cylinder head cover (engines 615, 616, 617)	15	(1.5)

### Special tools

Screw driver socket 10 mm, 1/2" drive, 140 mm long		000 589 05 07 00
Screwdriver with tommy bar for hexagon socket bolts 6 mm, 440 mm long		116 589 03 07 00
Torque wrench handle 50–200 Nm (5–20 kpm)		001 589 44 21 00
Attachable ratchet, 1/2" drive for torque wrench handle		001 589 42 09 00

### Note

Hexagon socket cylinder head bolts must be retightened after 500–1000 km (with the exception of (AUS), (J), (S) and (USA) versions starting 1977).

Twelve-point socket cylinder head bolts need not be retightened after 500–1000 km.

Warm up engine to operating temperature.

### Retightening

- 1 Referring to tightening diagram, slacken each cylinder head bolt in turn by about 90° and then tighten to 100 Nm (10 kpm).
- 2 Retighten M 8 bolts using key wrench.

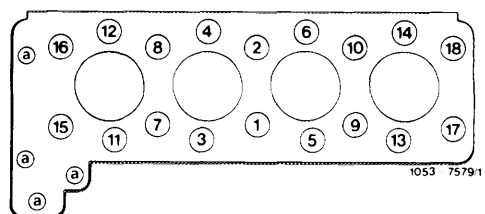

Engines 615, 616

**Note:** The M 8 bolt beneath the old tension rail version (steel rail with rubber backing) cannot be retightened.

It is not necessary to check valve clearance after re-tightening cylinder head bolts.

Engine 617

