

05—115 Removal and installation of cylinder head

Valve clearance	engine cold (approx. 20 °C)	engine hot (approx. 60 °C ± 15 °C)
Intake	0.10 ¹⁾	0.15 ¹⁾
Exhaust	0.30	0.35



¹⁾ 0.05 mm greater for steady ambient temperatures below -20 °C.





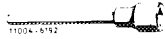
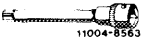
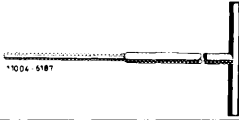
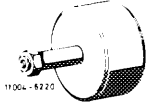

Timing for 2 mm valve lift

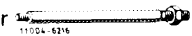
Engine	Camshaft code ¹⁾	Intake valve opens after TDC	closes after BDC	Exhaust valve opens before BDC	closes before TDC
615.912/913 615.940 (40 kW) 615.941 616.916	02 06 ²⁾	with new timing chain			
		11.5°	13.5°	21°	19°
		with used timing chain (from about 20.000 km)			
		13.5°	15.5°	19°	17°
615.940 (44 kW) 616.912 (53 kW)	10 ²⁾	with new timing chain			
		9°	15°	27°	16°
		with used timing chain (from about 20.000 km)			
		11°	17°	25°	14°
617.910 617.912 (59 kW)	00 08 ²⁾	with new timing chain			
		11.5°	13.5°	21°	19°
		with used timing chain (from about 20.000 km)			
		13.5°	15.5°	19°	17°
		with new timing chain			
		with used timing chain (from about 20.000 km)			

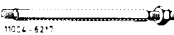
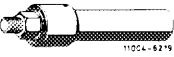
¹⁾ The camshaft code is stamped in the aft end of the camshaft.

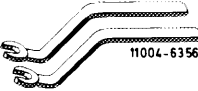
²⁾ Camshaft made of chilled casting.

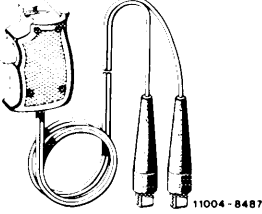
Tightening torques		Nm	(kpm)
Bolts for cylinder head cover (engine 615)		5	(0.5)
Nuts for cylinder head cover (engines 615, 616, 617)		15	(1.5)
Hexagon socket cylinder head bolts (engine cold)	1st step	70	(7)
	2nd step	90	(9)
	Settling time	10 min	
	3rd step	100	(10)
Twelve-point socket cylinder head bolts (engine cold)	1st step	40	(4)
	2nd step	70	(7)
	Settling time	10 min	
	3rd step	90°	
	4th step	90°	
Waisted bolt for camshaft sprocket		80	(8)
Nozzle holder in precombustion chamber		70–80	(7–8)
Bolts for rocker arm brackets on cylinder head		40	(4)
Special tools			
Socket 27 mm, 1/2" drive to crank engine		001 589 65 09 00	
Screwdriver socket 10 mm, 1/2" drive, 140 mm long for hexagon socket cylinder head bolts		000 589 05 07 00	
Screwdriver socket, 1/2" drive, 140 mm long for twelve-point socket cylinder head bolts		617 589 00 10 00	
Screwdriver with tommy bar for hexagon socket bolts 6 mm, 440 mm long		116 589 03 07 00	
Impact extractor for bearing pin (basic unit)		116 589 20 33 00	
Stud for impact extractor M 6, 50 mm long		116 589 01 34 00	
Threaded stud M 6, 150 mm long for impact extractor		116 589 02 34 00	

Threaded stud M 8, 150 mm long for impact extractor		616 589 00 34 00
Extractor for tension rail bearing pin (basic unit)		115 589 20 33 00
Threaded stud M 6, 30 mm long for extractor		115 589 01 34 00
Threaded stud M 8, 30 mm long for extractor		115 589 00 34 00
Valve adjusting wrench 14 mm (two)		615 589 00 01 00
Holding wrench for valve spring cap		615 589 00 03 00
Remote starter switch for cranking engine (individual component of compression pressure recorder 001 589 46 21 00)		001 589 46 21 08
Torque wrench handle 50–200 Nm (5–20 kpm)		001 589 44 21 00
Attachable ratchet, 1/2" drive for torque wrench handle		001 589 42 09 00

Note

Cylinder head must only be removed when engine is cold. Remove together with exhaust manifold and intake pipe.

Twelve-point socket cylinder head bolts (B) no longer need retorquing at the 1st inspection (500–1000 km) or after 500–1000 km following repairs.

In contrast, hexagon socket cylinder head bolts (A) need retorquing after 500–1000 km following repairs (05–105). This does not apply to (AUS), (J), (S) and (USA) versions starting 1977.

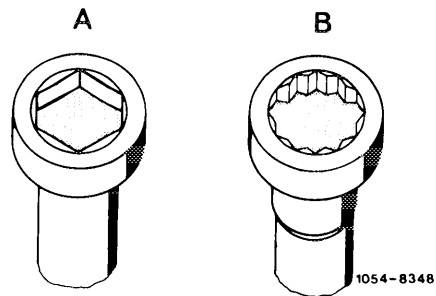

A Hexagon socket cylinder head bolt
B Twelve-point socket cylinder head bolt

Make sure that the correct cylinder head gasket is selected (05–100).

When using new cylinder heads, fit appropriate connections and screw plugs (05–100).

Cylinder head gaskets are supplied in welded film from which they must not be removed until just before use, because they are affected by light and ozone.

Removal

- 1 Fully drain coolant.

Drain plug in crankcase

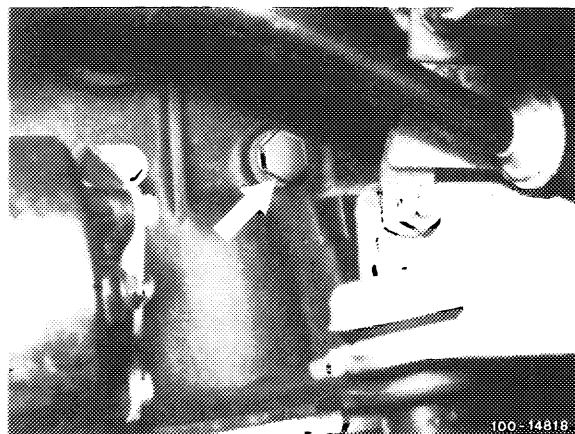

- 2 For type 123.1 move engine hood to 90° position and lock at left-hand latch (arrow).

- 3 Remove dry air cleaner. For oil bath air cleaner, release and detach rubber gaiter from throttle valve housing.

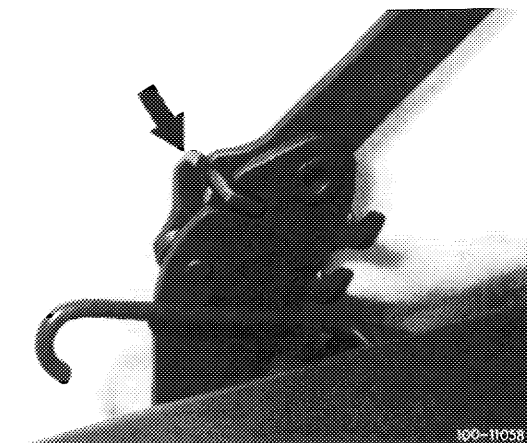

- 4 On vehicles with air conditioners, detach Yord refrigeration compressor with bracket and connected lines, depositing on one side.

First remove fan and water pump pulley; on engines with oil bath air cleaners, remember to remove air cleaner cover.

On engine 617.912 remove adapter at air cleaner (arrow).

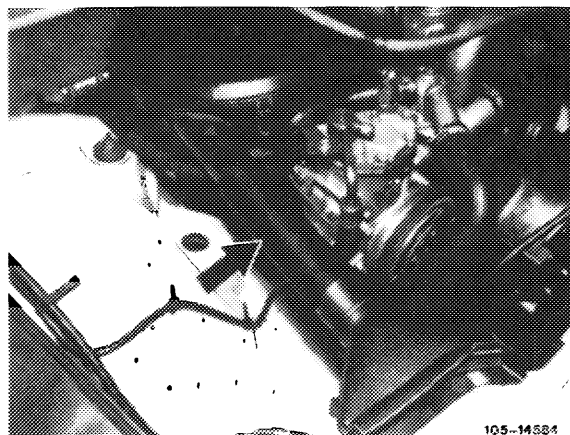

5 On vehicles with level control, unscrew delivery oil pump with connected lines, depositing on one side. Remove driver.

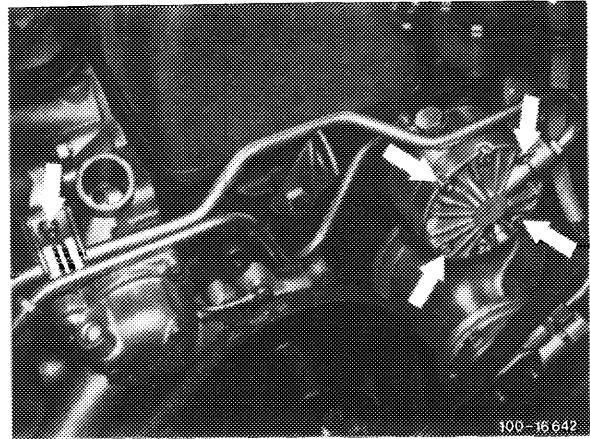

6 In type 123.1 with power steering remove power steering pump together with bracket and fuel filter. For this purpose suck oil off, remove bolts (arrows) and unscrew bracket of oil dipstick guide tube (arrow).

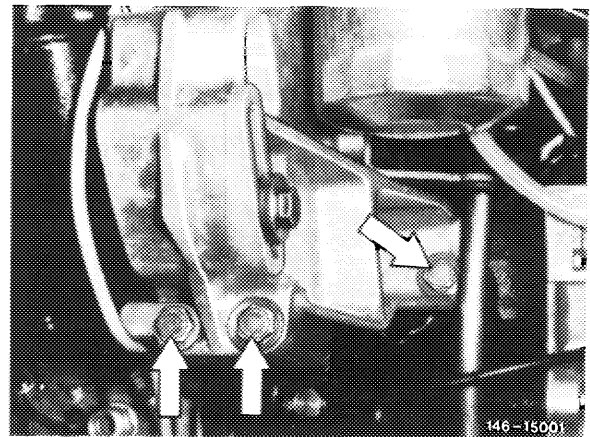

7 Detach all electric connections, hot water, fuel and vacuum lines from cylinder head and intake pipe.

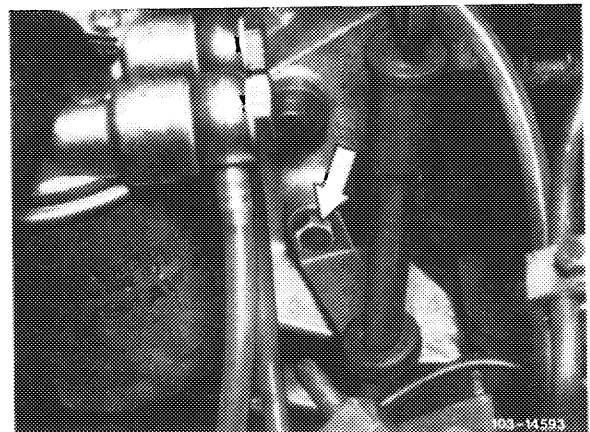
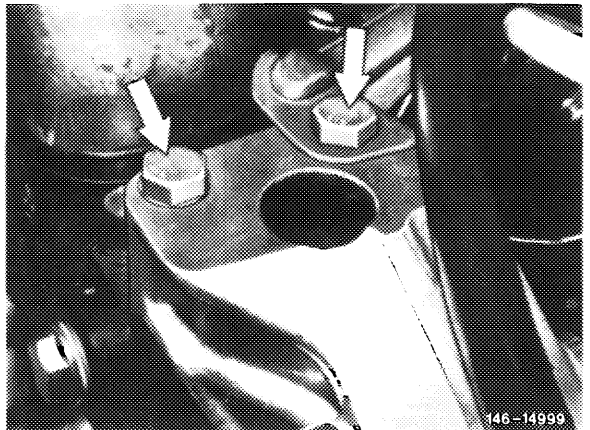

8 In type 123.1 without power steering, detach fuel filter together with connected hoses. For this purpose remove both bolts (arrows) and detach hose running to 1st injection nozzle.

In type 115.1 detach fuel filter together with connected hoses.

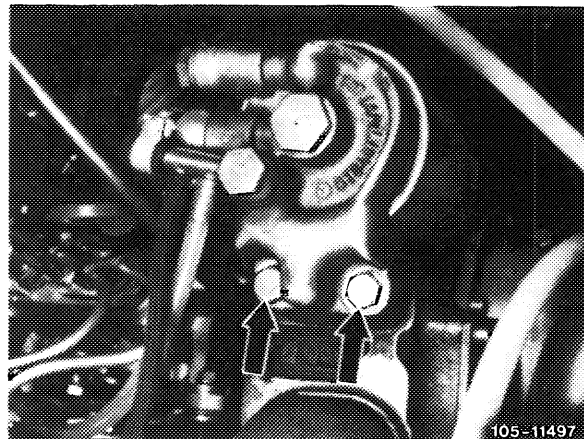

9 Unscrew oil dipstick guide tube of automatic transmission at intake pipe (arrow).

10 Unscrew exhaust line at exhaust manifold and transmission.

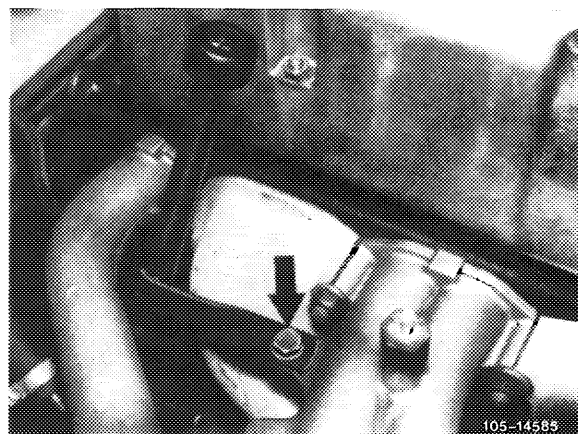

11 On engine 616.912 with dry air cleaner unscrew intake pipe support on intake pipe (arrow).

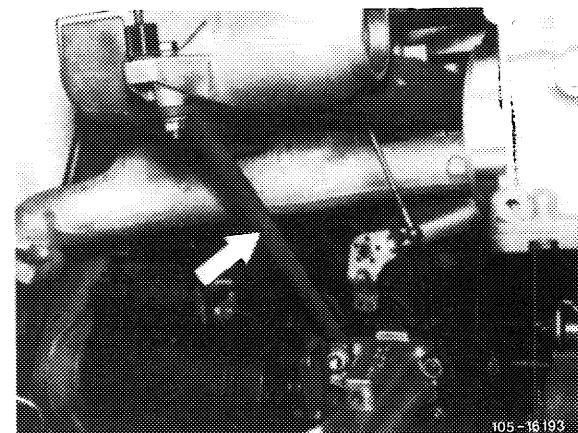

12 Detach throttle linkage and remove longitudinal control spindle.

Detach all control rods. Withdraw retainer (arrow) and force longitudinal control spindle in aft direction. Unscrew bracket (1) and unclip idle control cable (2) with plastic sleeve (3).

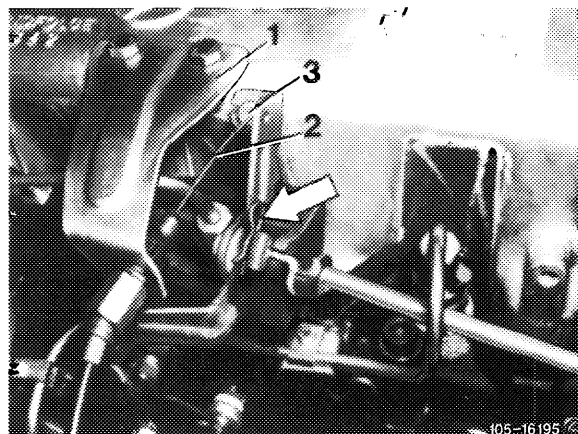

13 Remove injection lines and cover connections.

14 Close three water hoses at thermostat housing (arrows).

15 Unscrew ventilation line between cylinder head and water pump housing.

16 Remove cylinder head cover.

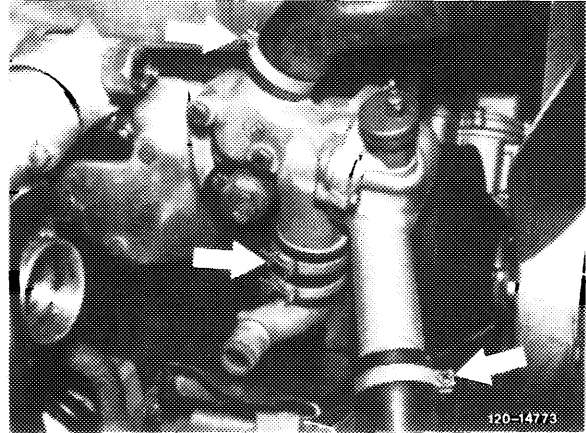

17 On engines with tension rail version (A) remove chain tensioner. Detach thermostat housing for this purpose.

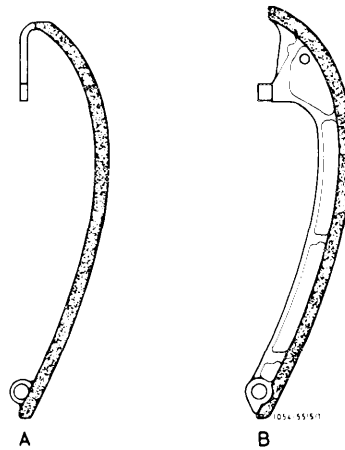

18 Release waisted bolt holding camshaft sprocket; do not remove.

In order to release camshaft sprocket, secure with screwdriver or steel pin.

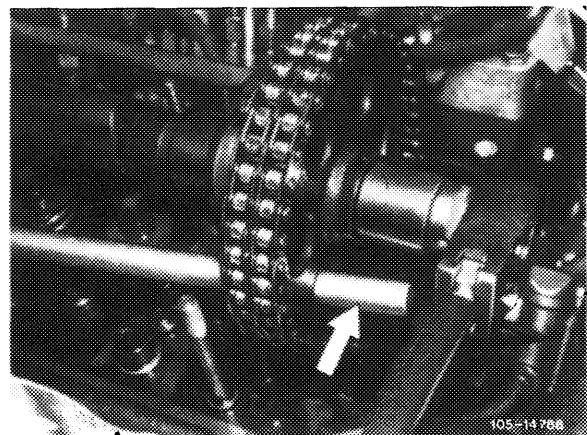

19 Remove both rocker arm assemblies. For this purpose position camshaft so that rocker arms are free.

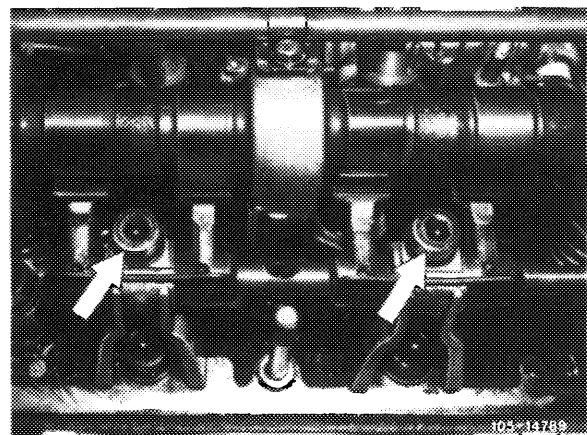

20 Move No. 1 cylinder piston to TDC. For this purpose turn engine at crankshaft, using tool combination.

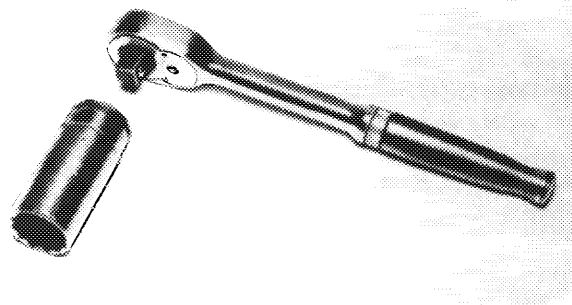

R 100/6498

21 Mark camshaft sprocket and timing chain to show how they fit together.

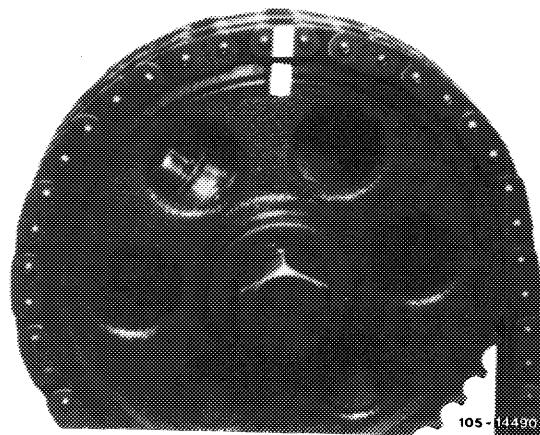

105-14490

22 Remove slide rail from cylinder head. Withdraw bearing pin using impact extractor.

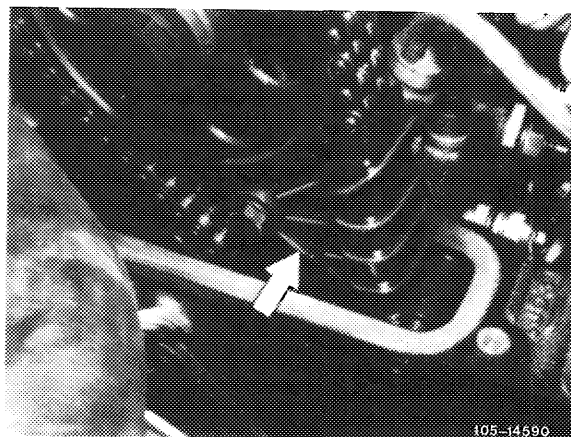

105-14590

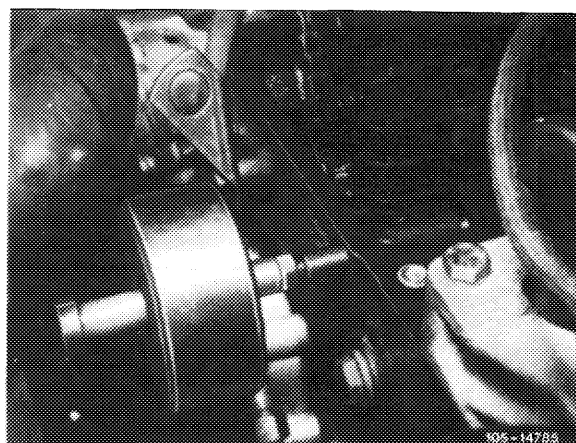

105-14784

23 On engines with lightweight tension rail version (B) slacken thrust pin of chain tensioner.

24 Remove camshaft sprocket.

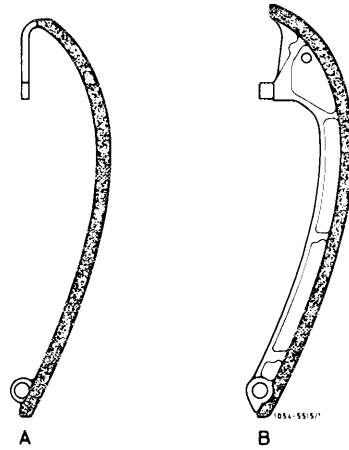

25 On engines with tension rail version (A), attach remover and installer, part No. 115 589 14 61 00, to tension rail.

Caution:

This tool is suitable only for engines with tension rail version (A).

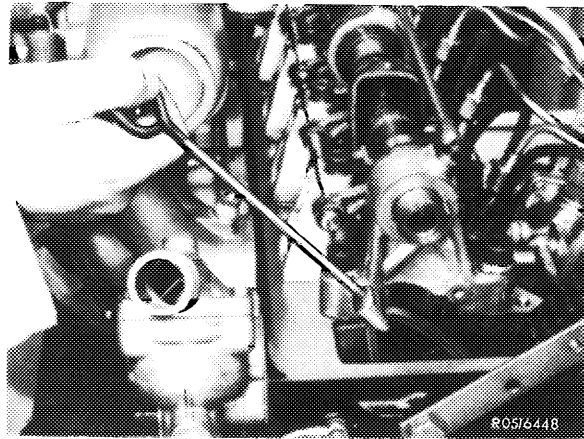

26 For tension rail version (A) drive out bearing pin using impact extractor. When dealing with engine 616.916 remove pulley for this purpose.

On engines with tension rail version (B) do not remove tension rail.

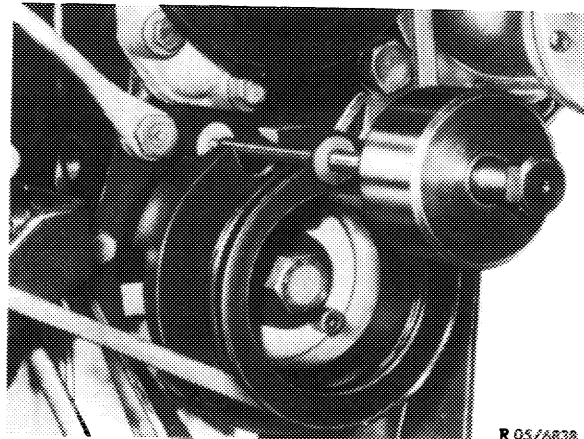

Caution:

If bearing pin is so firmly seated that it cannot be driven out with impact extractor, use extractor as per part No. 115 589 20 33 00. For this purpose unscrew pulley.

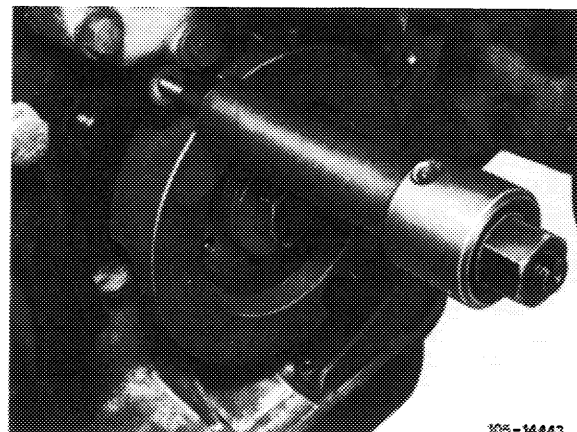

27 Using screwdriver socket, release and unscrew cylinder head bolts in reverse order to tightening diagram.

Unscrew M 8 bolts using 440 mm long/6 mm key wrench.

Engines 615, 616

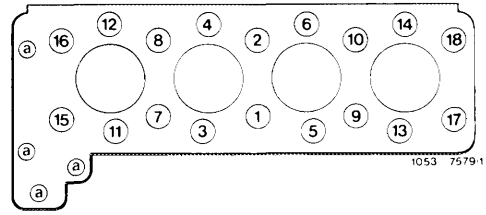

28 In order to unscrew 4/5 cylinder head bolts adjacent to injection nozzles, remove the nozzles.

Engine 617

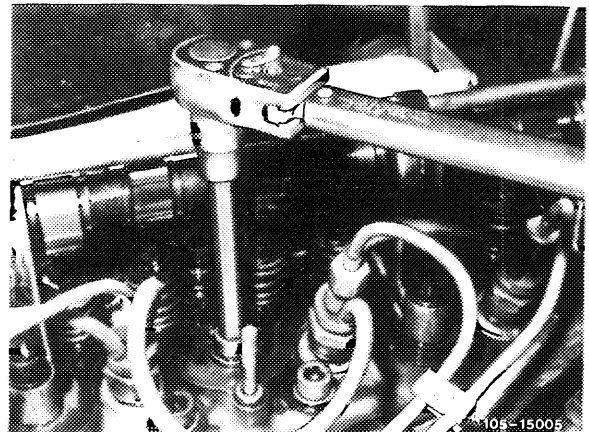
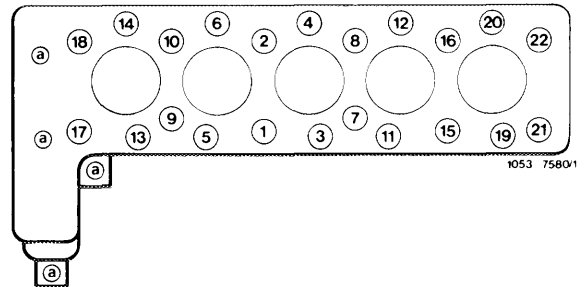

29 Lift cylinder head up and out. In type 123.1 this operation can be executed with a crane and engine hoist. The ropes are to be attached to the three suspension lugs for this purpose.

Suspension lug front

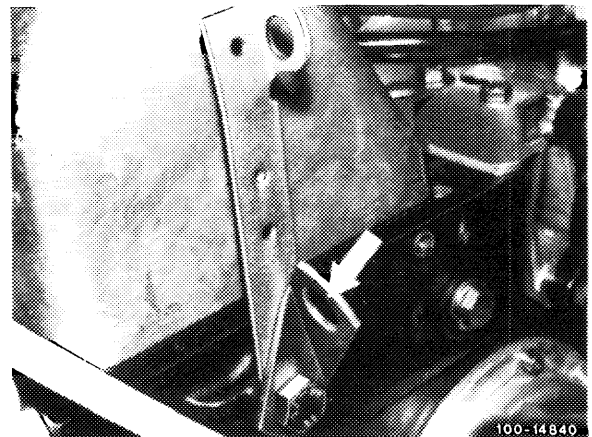

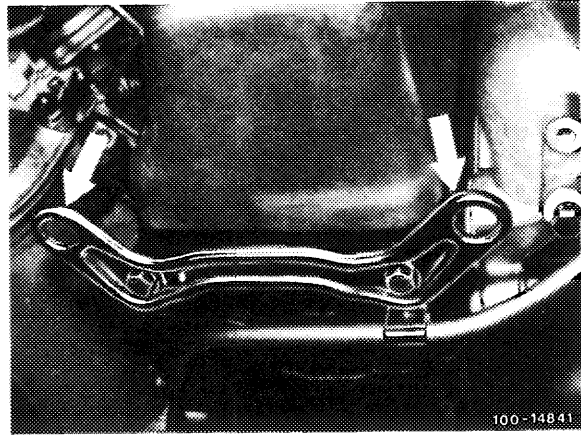

Suspension lugs rear

30 Thoroughly clean crankcase and cylinder head parting surfaces.

Installation

31 Fit new cylinder head gasket (05–100).

32 Place cylinder head in position, noting the locating sleeves for cylinder head.

33 Twelve-point socket cylinder head bolts are to be measured for length (L). Use new cylinder head bolts if dimension according to table is exceeded (05–105).

Thread dia.	Length (L) as new	Max. length (L) (replace)
M 12	104	105.5
M 12	119	120.5
M 12	144	145.0

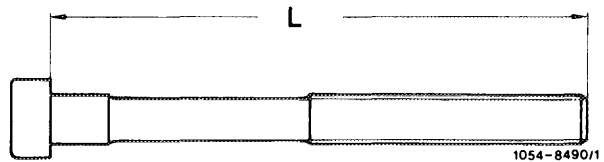

34 Oil threads and head supporting surfaces of cylinder head bolts, and then insert.

35 Tighten cylinder head bolts step by step in the order of the tightening diagram, beginning at bolt No. 1.

Engines 615, 616

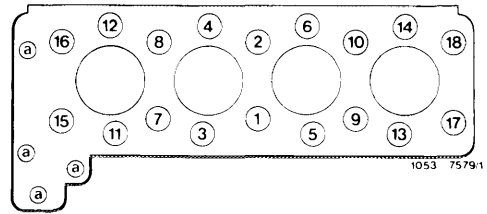

Caution:

Hexagon socket cylinder head bolts are to be tightened by torque, and twelve-point socket cylinder head bolts by initial torque and torquing angle (05–105).

Engine 617

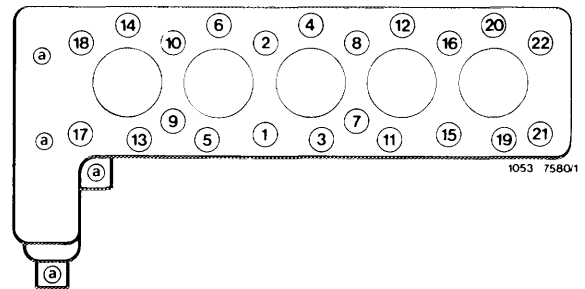

Estimate torquing angle. For this purpose position adjustable torque wrench handle in ratchet at **released position** (locked). Apply adjustable torque wrench handle and ratchet parallel to center line of engine, and turn until it is at right-angles to engine.

Do not use a torque-limiting wrench for applying the torquing angle.

Hexagon socket cylinder head bolts (A)

1st step	70 Nm	(7 kpm)
2nd step	90 Nm	(9 kpm)
Settling time	10 min	
3rd step	100 Nm	(10 kpm)

Twelve-point socket cylinder head bolts (B)

1st step	40 Nm	(4 kpm)
2nd step	70 Nm	(7 kpm)
Settling time	10 min	
3rd step	90°	
4th step	90°	

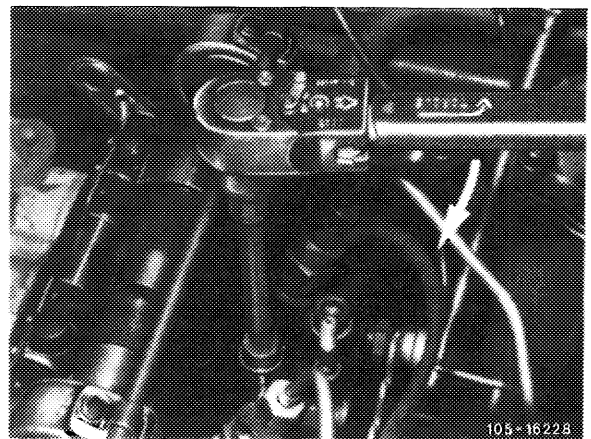

Tighten M 8 bolts using key wrench.

36 On engines with tension rail version (A), install tension rail.

37 Place camshaft sprocket on camshaft with timing chain. Remember to note color marking.

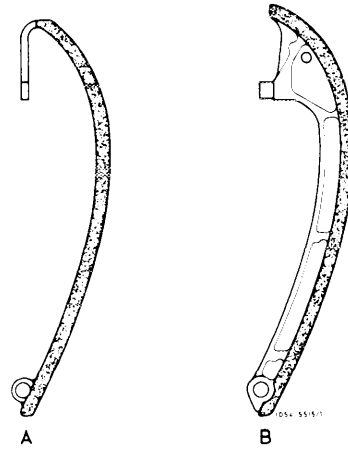

38 Insert waisted bolt of camshaft sprocket and torque to 80 Nm (8 kpm).

For this purpose secure camshaft sprocket with screwdriver or steel pin.

39 Install both rocker arm assemblies.

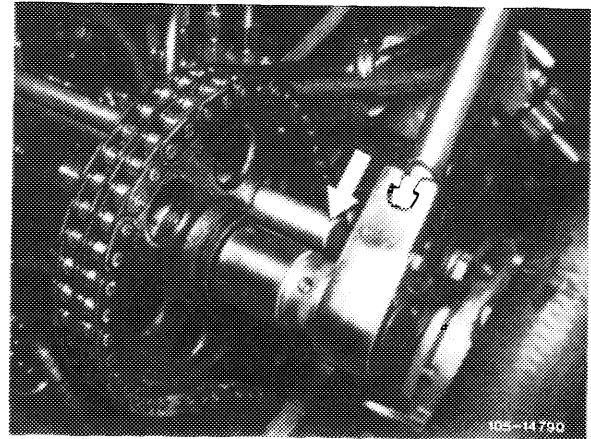

40 Applying tool combination to crankshaft, turn engine so that No. 1 cylinder piston is at TDC. Check adjusting marks.

Check timing if cylinder head has been refaced (05--215).

41 Install slide rail.

42 On engines with tension rail version (A, illustration of job No. 36), install chain tensioner.

43 Adjust valve clearance (05--210).

44 Install injection nozzles, first inserting new nozzle plates.

45 Now proceed in reverse order of removal.

46 Fill system with coolant and subject cooling system to pressure-test.

47 Tighten V-belts as specified (13--340).

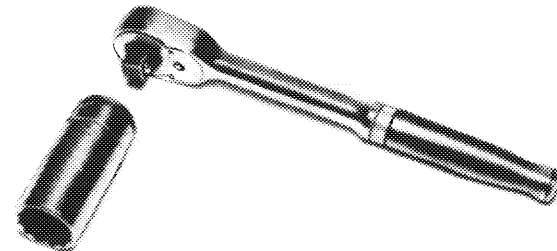

R 100/6498

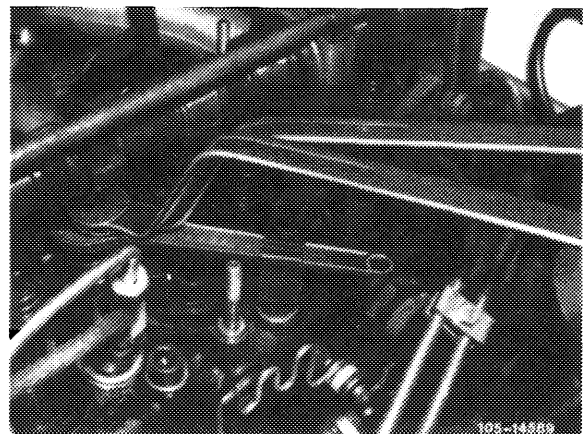

48 Vent injection system with hand-operated pump.

49 Run engine and check for leakage.

Caution:

Hexagon socket cylinder head bolts no longer need re-torquing hot (05–105).

50 Hexagon socket cylinder head bolts are to be re-tightened after 500–1000 km. This does not apply to (AUS) , (J) , (S) and (USA) versions starting 1977.

Twelve-point socket cylinder head bolts do not need retorquing.

Cylinder head and cylinder head cover
 Engine 617.912

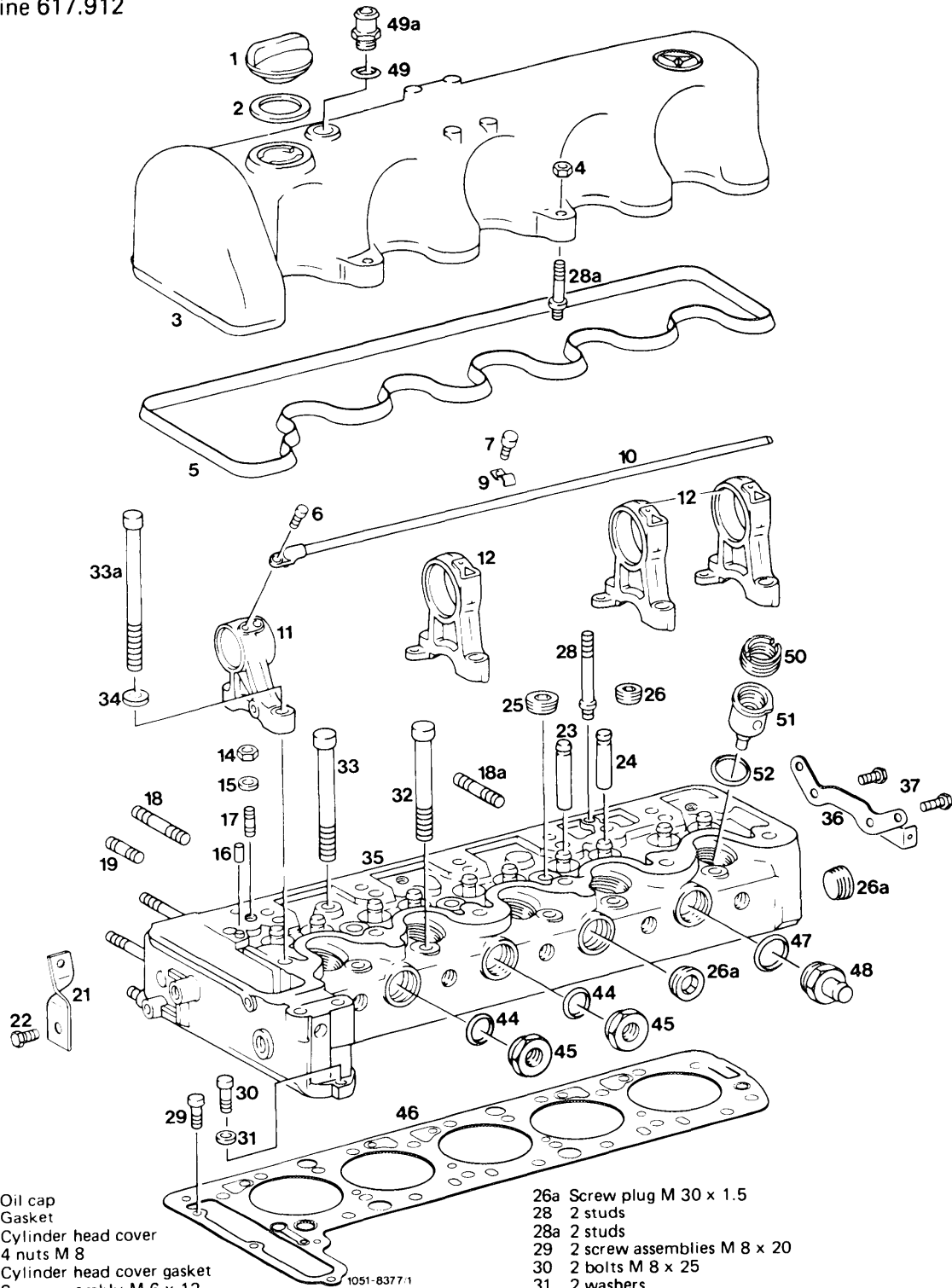

- | | | | |
|-----|--------------------------------|-----|-----------------------------------|
| 1 | Oil cap | 26a | Screw plug M 30 x 1.5 |
| 2 | Gasket | 28 | 2 studs |
| 3 | Cylinder head cover | 28a | 2 studs |
| 4 | 4 nuts M 8 | 29 | 2 screw assemblies M 8 x 20 |
| 5 | Cylinder head cover gasket | 30 | 2 bolts M 8 x 25 |
| 6 | Screw assembly M 6 x 12 | 31 | 2 washers |
| 7 | 3 screw assemblies M 5 x 10 | 32 | 5 cylinder head bolts M 12 x 105 |
| 9 | 3 clips | 33 | 9 cylinder head bolts M 12 x 120 |
| 10 | Oil pipe | 33a | 8 cylinder head bolts M 12 x 145 |
| 11 | Camshaft bearing, cranking end | 34 | 22 washers |
| 12 | Camshaft bearing | 35 | Cylinder head |
| 14 | 4 nuts M 8 | 36 | Suspension lug |
| 15 | 4 washers 8.4 | 37 | Bolt M 8 x 16 |
| 16 | 8 straight pins 8 x 8 | 44 | Sealing ring A 30 x 36 |
| 17 | 4 studs M 8 x 18 | 45 | Screwed union |
| 18 | 5 studs M 10 x 52 | 46 | Cylinder head gasket |
| 18a | Stud M 10 x 40 | 47 | Sealing ring A 30 x 36 |
| 19 | Stud M 10 x 30 | 48 | Threaded union, heater connection |
| 21 | Suspension lug | 49 | Sealing ring A 18 x 24 |
| 22 | Bolt | 49a | Pipe union |
| 23 | 5 valve guides, intake | 50 | 5 screw collars |
| 24 | 5 valves guides, exhaust | 51 | 5 precombustion chambers |
| 25 | 4 screw plugs M 26 x 1.5 | 52 | 5 sealing rings |
| 26 | Screw plug M 22 x 1.5 | | |