

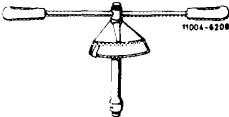

07.1–230 Removal and installation of injection nozzles (injectors)

Tightening torques		Nm
Injection nozzles		70–80
Injection lines		25
Special tools		
Torque wrench 1/2" square, 40–130 Nm		000 589 22 21 00
Torque wrench 1/2" square, 15–65 Nm		000 589 27 21 00
Box wrench insert open, 17 mm, 1/2" square for injection lines		001 589 65 09 00

Removal

- 1 Unscrew injection lines.
- 2 Pull off fuel hoses for leak oil and closing plugs of 4th or 5th injection nozzle.
- 3 Unscrew injection nozzles by means of socket. If a threaded ring of prechamber comes loose, retighten all threaded rings (05–117).
- 4 Remove nozzle plates.
- 5 Complete visual checkup of prechamber. For this purpose, illuminate with a flashlight and check whether ball pin is in order.

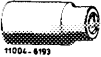
- 50 Threaded ring
- 51 Prechamber
- 52 Sealing ring
- 53 Nozzle plate
- 80 Nozzle holder combination
- 81 Pencil-element glow plug

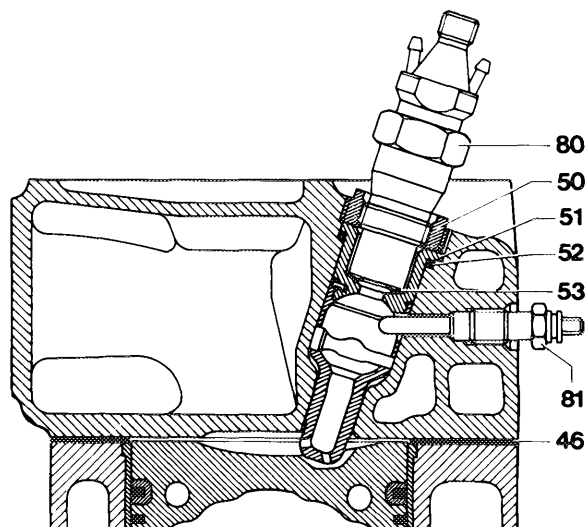

1073 - 9935

Installation

6 For installation proceed vice versa. Use **only resilient nozzle plates from now on**. Pay attention to tightening torques.

Attention!

Resilient nozzle plate may be used only once.